

# ARBUS 270

*English version - MI-0102*



**MÁQUINAS AGRÍCOLAS JACTO S.A.**

Rua Dr. Luiz Miranda, 1650

17580-000 - Pompéia - SP - Brazil

Tel: +55 14 3405-2100 - Fax: +55 14 452-1012

E-mail: [impex@jacto.com.br](mailto:impex@jacto.com.br)

Home page: [www.jacto.com.br](http://www.jacto.com.br)

**EDITION : 06/2002**

**CODE: 783324**



## INTRODUCTION

The agrochemicals application is necessary to achieve higher and economical production.

However, as it is a work that can bring risks to the human being, environment and crops, Jacto has always been concerned with the proper use of its spraying machineries in an efficient and safe way.

Therefore, read carefully and understand thoroughly this manual before operating this sprayer and keep it always at hand when handling this sprayer for quick consult in case you are not quite sure of some operation or adjustment.

Should your doubt persist, please contact your Jacto dealer.

**MÁQUINAS AGRÍCOLAS JACTO S.A.**  
**CONTRIBUTING TO THE AGRICULTURE DEVELOPMENT.**

## IDENTIFICATION PLATE

Your sprayer has a plate showing its model and serial number.

This information is very important so that Jacto can keep records of eventual modifications made on the material used and on its construction characteristics.

In requesting replacement parts or maintenance, always specify the model and serial number of your sprayer for prompt and efficient service.



Jacto and Arbus are trademarks registered by Máquinas Agrícolas Jacto S.A.

**JACTO RESERVES THE RIGHT TO CHANGE SPECIFICATIONS AND DESIGN  
WITHOUT PRIOR NOTICE.**

# TABLE OF CONTENTS

<b>Safety instructions</b>	
- Handling agricultural sprayers .....	05
- Handling agrochemicals .....	06
<b>Presentation of sprayer</b>	
- ARBUS 270 .....	07
<b>Main components of sprayer</b>	
- Suction filter .....	09
- Pump .....	09
- Pressure regulator .....	09
- Nozzles .....	10
- Fan .....	11
- Standard PTO shaft .....	11
- Spray lance (optional) .....	11
- Filling unit (optional) .....	12
- Spray gun (optional) .....	12
- Bypass valve (optional) .....	13
- Row crop deflector (optional) .....	13
- One-way deflector (optional) .....	14
<b>Operational procedures .....</b>	<b>15</b>
<b>Choosing the ideal tractor .....</b>	<b>16</b>
<b>Setting up tractor .....</b>	<b>17</b>
<b>Mounting the sprayer to the tractor .....</b>	<b>19</b>
<b>Operation and adjustments</b>	
- Spray application technology .....	20
- Nozzles flow rate .....	21
- Calibrating the sprayer .....	23
- Diluting the agrochemicals .....	24
<b>Maintenance</b>	
- Guidelines .....	25
- Components .....	25
- Lubrication table .....	26
- Components lubrication .....	26
- Belts tension .....	26
- PTO shaft .....	27
- Decals .....	28
- Winter storage .....	29
- Trouble-shooting .....	30
<b>General care</b>	
- Handling agricultural sprayers and chemicals .....	33
- After spraying .....	33
<b>Statement of limited warranty .....</b>	<b>34</b>

# SAFETY INSTRUCTIONS

## HANDLING AGRICULTURAL SPRAYERS

### OWNER / OPERATOR:

This sprayer was carefully designed and built so as to give you the maximum production, saving, easy operation and safety.

Therefore, you or anyone else who is going to operate, maintain and work around this sprayer must read and understand this manual thoroughly in order to be familiar with all the operating and maintenance procedures and safety information related to this sprayer. All accidents can be prevented if all the safety instructions are correctly followed.

Moreover, always keep this manual close at hand for quick review in case of doubt.

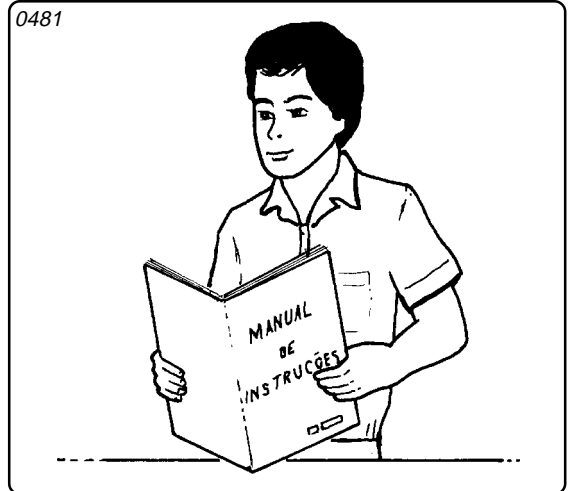

**ATTENTION**  
**FAILURE TO FOLLOW THE SAFETY**  
**INSTRUCTIONS PROPERLY WILL RISK YOUR**  
**OWN LIFE AS WELL AS THE LIFE OF PEOPLE**  
**WORKING AND LIVING AROUND YOU.**

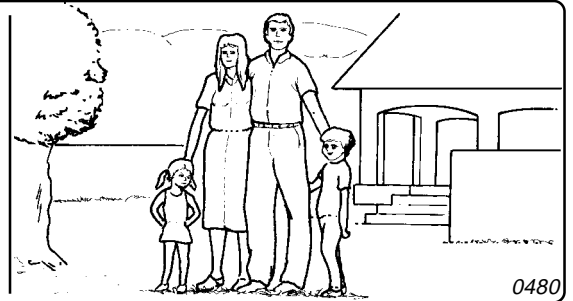

0355



This safety alert symbol identifies important safety messages. When you see it, be alert to any possibility of personal injury or death. Keep all the decals on the sprayer and replace them if missing or illegible.

- Before operating this sprayer, read carefully and understand thoroughly this manual.
- Do not allow untrained people to operate this sprayer because this can cause serious injuries or fatal accidents.
- Do not modify this sprayer in any way because this can impair the function and risk your safety.
- Keep away children, aged people and animals while operating, servicing this sprayer and even when the sprayer is stored.
- In the delivery of your sprayer, have your Jacto dealer instruct you on the assembly, operation, maintenance and warranty in detail.
- Keep hands, feet and clothing away from moving parts.
- Never use loose clothing or mittens while working around the sprayer.
- Do not travel at high speeds.
- **Always stop tractor engine, disengage the PTO and wait for all moving parts to stop before servicing, adjusting or repairing the sprayer.**

**ATTENTION: Do not touch PTO shafts, belts, fans or any other moving part while the sprayer is running.**

- Only unhitch the sprayer on firm and level ground.
- Keep your sprayer in thorough repair.

# SAFETY INSTRUCTIONS

## HANDLING CHEMICALS

Chemical products are classified in four categories of toxicity. According to their toxicity level, there is a special recommendation of appropriate protective equipment.

As your safety concerns first, we list below all the protective equipment recommended for handling chemical products of the category 1 which includes high toxicity level chemicals.

This way, all the possibilities of serious illness and death are eliminated.

### Obligatory individual protective equipment for handling and spraying chemicals:

- Long-sleeved working clothes
- Impermeable apron or coverall
- Impermeable gloves
- Impermeable wide-brimmed hat
- Boots
- Special protective masks equipped with appropriate filters for each type of product

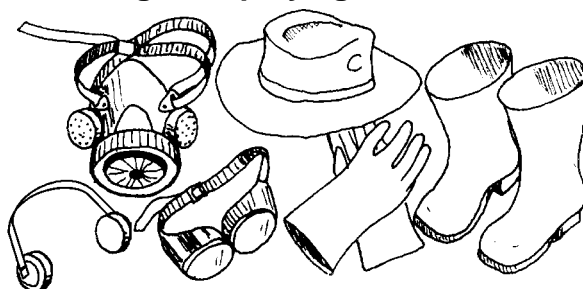

0478

## CHEMICAL PRODUCTS CLASSIFICATION

<span style="font-size: 2em;">☠</span> <span style="font-size: 2em;">☠</span>	<b>TOXICITY LEVEL</b>		<b>LABEL COLOR ON CHEMICALS CONTAINER</b>
	I	<b>HIGH</b>	<b>RED</b>
	II	<b>MODERATE</b>	<b>YELLOW</b>
	III	<b>LOW</b>	<b>BLUE</b>
	IV	<b>LIGHT</b>	<b>GREEN</b>

## DIRECTIONS

- Read and follow all instructions on the chemicals manufacturer's label.
- Keep the chemical products closed and in a dry and ventilated place.
- Use the chemical products in agriculture only.
- Keep away children, untrained people and animals.
- Handle the chemicals following recommendations of a technician.
- Always handle chemicals in a ventilated place and equipped with individual protective equipment.
- Use the application rate as per instructions on the labels.
- Do not make spray applications in the wind or hot weather.
- Do not drink, eat or smoke while spraying or handling chemicals.
- Keep children, untrained people and animals away from the application areas.
- Never blow through nozzles strainers, valves or pipelines by mouth.
- Do not store or transport chemical products together with food, medicines, people, animals.
- Make sure rivers, lakes, etc. will not be contaminated when washing out the sprayer.
- After spraying, take off all protective clothing and take a shower.
- In case of intoxication, go see a doctor immediately and show him the chemical products label.
- Never medicine an unconscious person through mouth.
- **Do not re-use the chemical products containers for other purposes. Consult an agronomist on how to discard empty containers of chemical products.**

# PRESENTATION OF SPRAYER

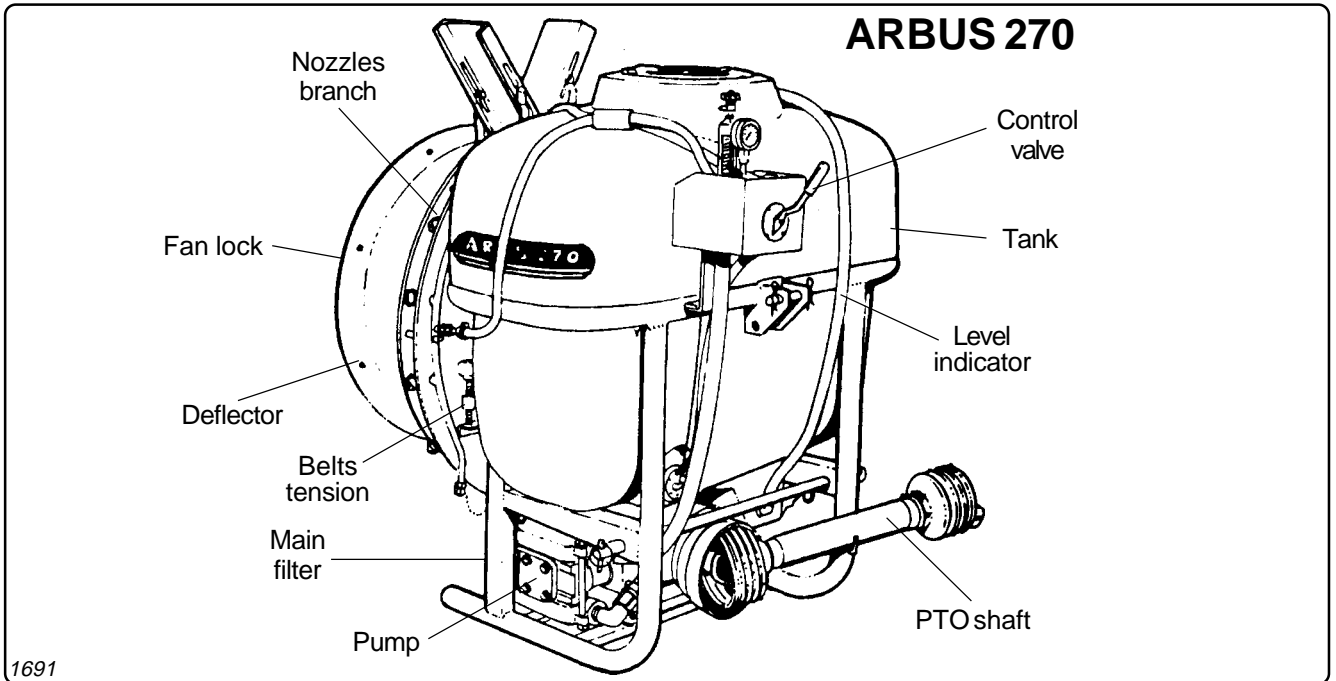

## TECHNICAL SPECIFICATIONS

Model .....	Arbus 270
Length (m) .....	1.00
Width (m) .....	1.05
Height (m) .....	1.15
Weight (kg) .....	181
Tank	
- Capacity (l) .....	270
- Material .....	Polyethylene (plastic)
Filter	
- Model .....	FVS-100
- Mesh .....	60
Pump	
- Model .....	JP-50
- Flow rate (l/min) at 540 rpm .....	50
- Maximum pressure (kg/cm <sup>2</sup> - psi) .....	28 - 400
- Power consumption (HP) at 400 psi .....	3.2
Nozzle holder	
- Model .....	With valve
- Quantity .....	10
- Nozzle model .....	JA-2
- Maximum pressure (kg/cm <sup>2</sup> - psi) .....	14 - 200
Pressure gauge .....	Glycerin-filled
Filling unit (optional)	
- Model .....	EJ-250
Level indicator .....	Hose attached to tank
Agitator .....	With hydraulic return
Working speed .....	From 2 to 6 km/h

# PRESENTATION OF SPRAYER

## FAN

SPECIFICATIONS	ARBUS 270
Fan diameter (mm)	615
Pulley diameter (mm)	80
Rotation (rpm)	2,000

PERFORMANCE	PLASTIC BLADES POSITION	
	*A	B
Air speed (km/h)	134	120
Air volume (m <sup>3</sup> /s)	6.84	6.13
Power consumption (HP)	8.7	6.3

\* This sprayer is shipped with the blades set in the position "A".

Total power consumption:

Pump ..... 3.2 HP

Fan (**position "A"**) ..... 8.7 HP

**TOTAL** ..... **11.0 HP**

# MAIN COMPONENTS OF SPRAYER

## SUCTION FILTER

Located between the tank and pump, the suction filter is specifically designed to prevent dirt or impurities from reaching the pump.

It has a quick shut off valve which allows easy filter cleaning, filtering elements changing and/or pump maintenance.

This valve must always remain open while the sprayer is running. If it remains closed, you will hear an unusual noise in the pump.

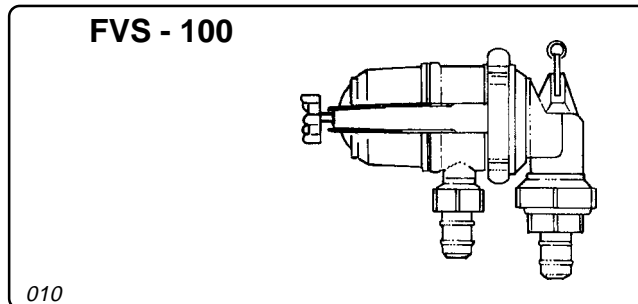

## PUMP

The pumps mounted to Jacto sprayers have flow rate ranging from 38 to 300 liters per minute.

PUMP MODEL	FLOW RATE (l/min)	MAXIMUM WORKING PRESSURE	
		psi	kg/cm <sup>2</sup>
JP - 402	38	300	21
JP - 50	50	500	35
JP - 75	75	500	35
JP - 100	100	500	35
JP - 150	150	500	35
JP - 300	300	500	35

The ceramic liners ensure greater resistance to abrasion and agrochemicals' action.

Piston cup replacement becomes easier by removing the head assembly in a quick and simple operation with no need to remove the pump.

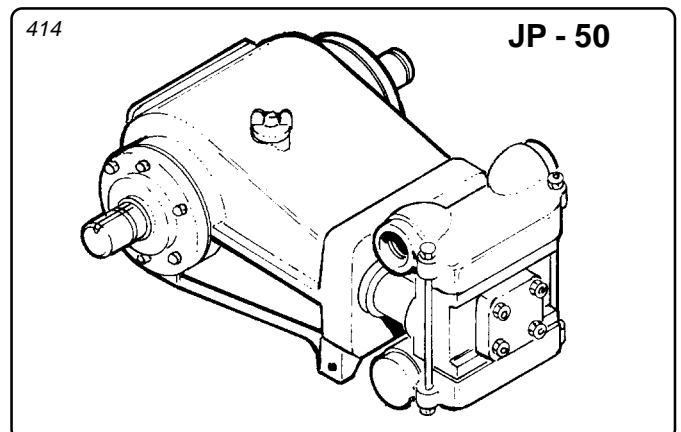

## PRESSURE REGULATOR

This pressure regulator provides calibration of up to 28 kg/cm<sup>2</sup> (400 psi), indicated by the pressure gauge.

The lever (1) turns on and off the chemical flow to right and left nozzles branches or to one only. This makes the application easier and with less wastage of agrochemicals.

**ATTENTION**

In order to ensure longer life of the pressure gauge, close the lever (1) after regulating the sprayer, thus releasing the pressure, and close the pressure gauge valve.

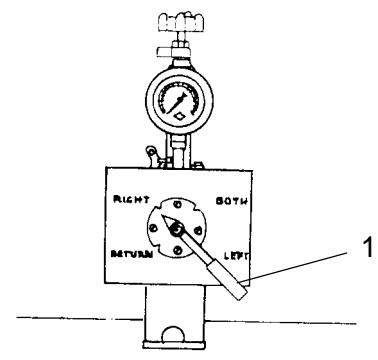

1685

# MAIN COMPONENTS OF SPRAYER

## NOZZLES

The nozzles have the job to generate droplets and distribute them uniformly over the surface being sprayed.

Flow, angle and droplet sizes vary according to working pressure. Operating with pressure over that recommended by the manufacturer will decrease the nozzles' life.

This sprayer is equipped with alumina (ceramic) nozzles, very resistant to wear and to chemical action, and mounted as shown in the figures below.

### NOZZLE HOLDER WITH VALVE

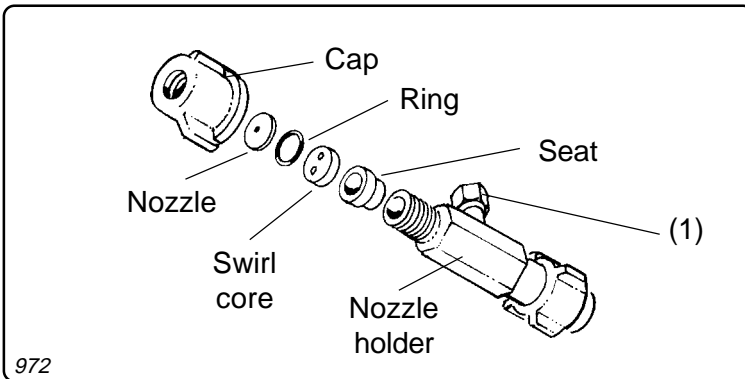

The nozzles holders with valve can be adjusted to desired angle and can be shut off individually.

**NOTE:** To adjust the nozzle, loosen the nut (1), set it in the desired position and retighten the nut.

**ATTENTION:** Do not overtighten the nut.

### DOUBLE NOZZLE HOLDER (OPTIONAL)

#### DIRECTING THE NOZZLE

Loosen the nut (1) and set the desired nozzle at the mark (A) existing on the nozzle body.

**NOTE:** This mark indicates the spray direction. So the nozzle at this mark is turned on.

#### CHANGING THE SPRAY VOLUME

With a simple 180° turn of the nozzle holder it is possible to turn off one nozzle and turn on the other.

#### SHUTTING THE FLOW

Just give the nozzle holder a 90° turn in relation to the mark (A) and the flow will be turned off.

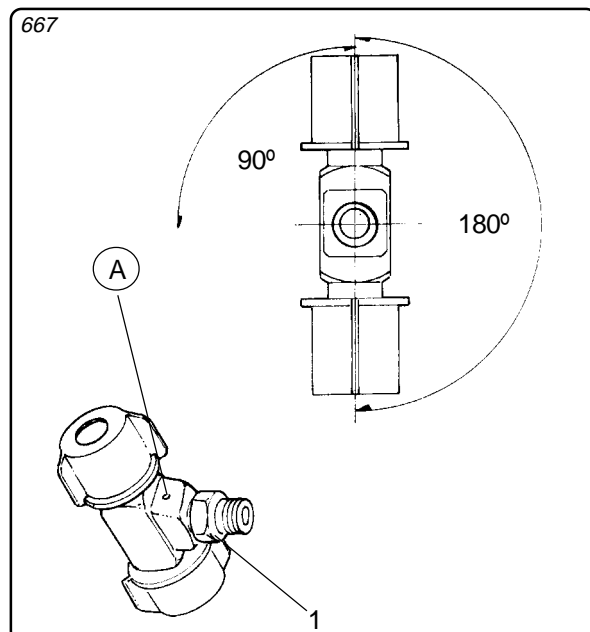
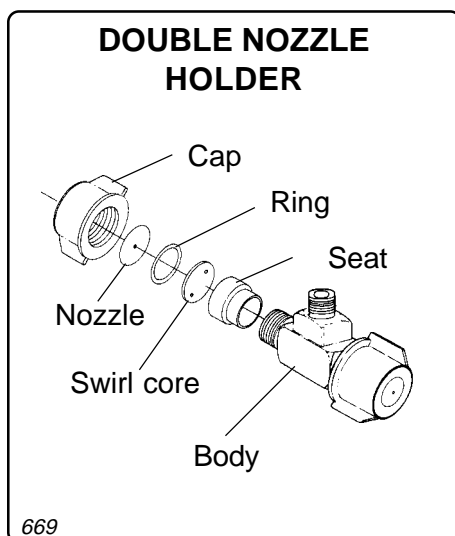

# MAIN COMPONENTS OF SPRAYER

## FAN

The fan has a locking device designed to be used during the tank filling, agitation of chemical mixture while spraying, as well as for spray lance application. The use of this device reduces power consumption in any of said operations.

To turn the fan off, pull the lock and give it a quarter turn. To turn it on, set the lock back.

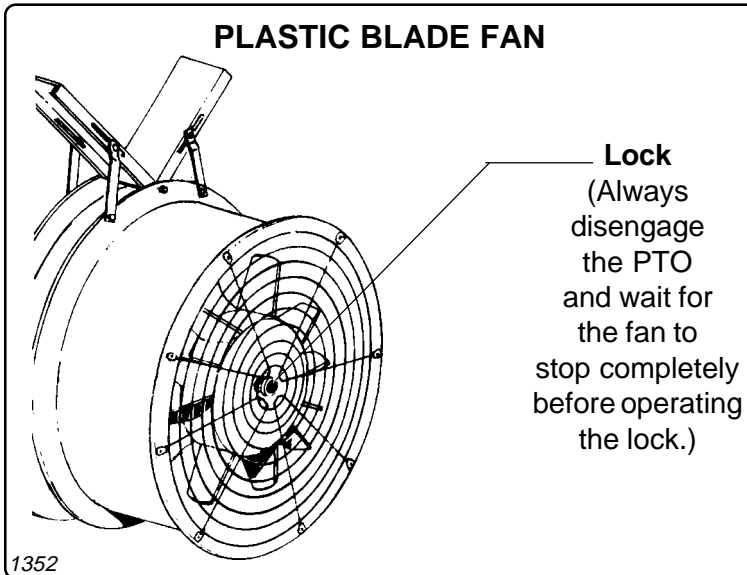

### ATTENTION

For tractors with independent PTO, the following is recommended:

- Do not engage the PTO with the engine accelerated.
- With the engine idling, engage the PTO and gradually accelerate until reaching the recommended rpm.

## STANDARD PTO SHAFT

The PTO shaft of this sprayer has plastic protection guards to prevent the operator and his clothes from touching the PTO shaft and to avoid damage to the plants while running.

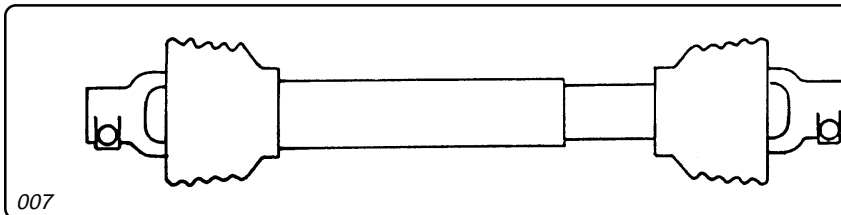

### NOTE:

For instruction in detail, refer to the section MAINTENANCE - PTO SHAFT.

## SPRAY LANCE (OPTIONAL)

This is an accessory for spot spraying, as well as for applications to difficult of access places.

It has two ceramic cone nozzles (model JA-2) and trigger valve for turning on and off the chemical flow, thus preventing wastage of agrochemicals.

Nozzle	Pressure (psi)	Flow rate (l/min)	
		Nozzle	Lance
JA-2	150	1.00	2.00
	200	1.16	2.32
	300	1.42	2.84
	400	1.64	3.28

Pressure band not recommended.

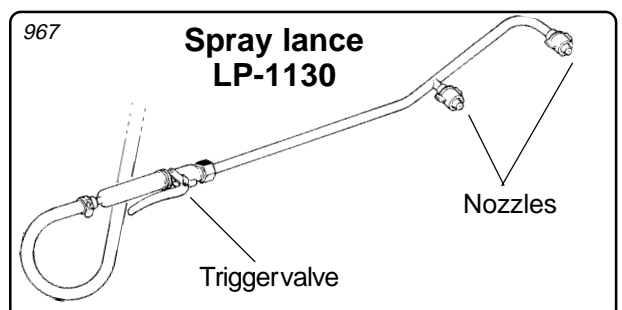

# MAIN COMPONENTS OF SPRAYER

## FILLING UNIT (OPTIONAL)

- Put 20 liters of clean water in the sprayer's tank.
- Disconnect the hose (1) from the pump and connect the filling unit hose (2) in its place.
- Put the filling unit (3) in the water source and the end of its discharge hose (4) into the tank filling opening.
- Engage the PTO with 540 rpm.
- After finishing the filling operation, connect again the hose (1) to the pump.
- Run the sprayer for five minutes before starting to spray, so that the chemical mixture is homogeneous.

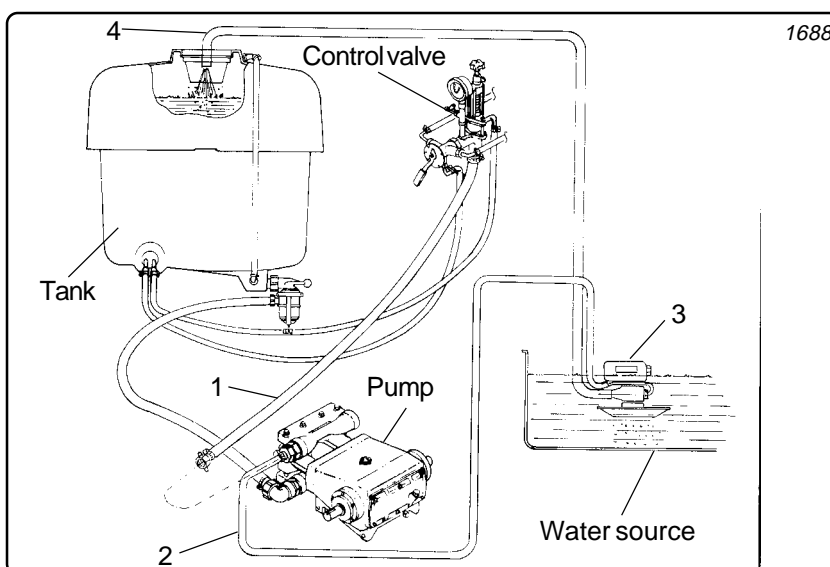

## ATTENTION

- THE SPRAYER FILLING OPERATION MUST BE DONE IN PLACES APPROPRIATE FOR THIS PURPOSE OR THROUGH APPROPRIATE VEHICLES (TRUCKS, TRAILERS, ETC.).
- NEVER COLLECT WATER FROM RIVERS, LAKES, DAMS, STREAMS, BROOKS, ETC. BY USING THE SPRAYER'S RETURN SYSTEM.

## SPRAY GUN (OPTIONAL)

This is a component for spot spraying on big plants requiring high application rate.

It is possible to have flow rate ranging from 5 to 45 liters per minute by shifting the spray discs.

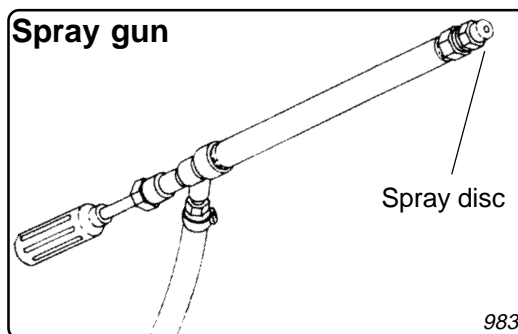

## SPRAY DISCS - SERIES D

Made in stainless steel, these discs are designed to be used on the Jacto spray gun for spot spraying on fruit trees due to its large application range, as well as for cleaning sheds, warehouses and agricultural equipment.

The spray discs are available with flow rate ranging from 5 to 45 liters per minute.

### FLOW RATE TABLE

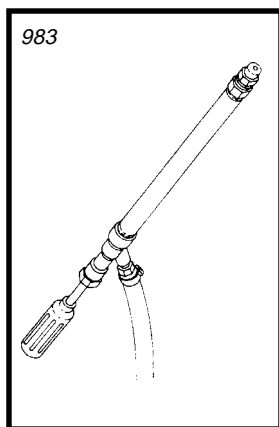

DISC PART #	DISC MODEL	PRESSURE (psi)				
		100	150	200	300	400
		SPRAY GUN FLOW RATE (l/min)				
202275	D - 5	5.20	6.00	7.00	8.00	9.50
202267	D - 6	6.85	8.50	10.00	12.00	13.50
202811	D - 7	9.35	10.90	12.50	14.75	17.00
202259	D - 8	12.85	15.00	17.00	20.00	23.65
622829	D - 9	14.20	17.64	20.72	25.40	29.40
114686	D - 10	18.50	22.00	25.50	30.00	35.68
622837	D - 11	21.00	24.75	29.35	37.00	45.00

1068

## MAIN COMPONENTS OF SPRAYER

### FLOW BYPASS VALVE (OPTIONAL) - FOR USE WITH SPRAY GUN OR LANCE

- Install the flow bypass valve (1) on the screw fastening the frame.
- Take off the plug (2) from the nozzle branch (3).
- Disconnect the chemical mixture hose (4) from the nozzle branch (3).
- Connect the bypass valve (1) to the nozzle branch (3).
- Use the plug (2) to stop up the nozzle branch (3).
- Connect the hose (4) with the hose (5).
- Install the spray lance or gun on the flow bypass valve.
- To use the spray lance or gun the lever (6) of the bypass valve should be positioned as shown in the figure.

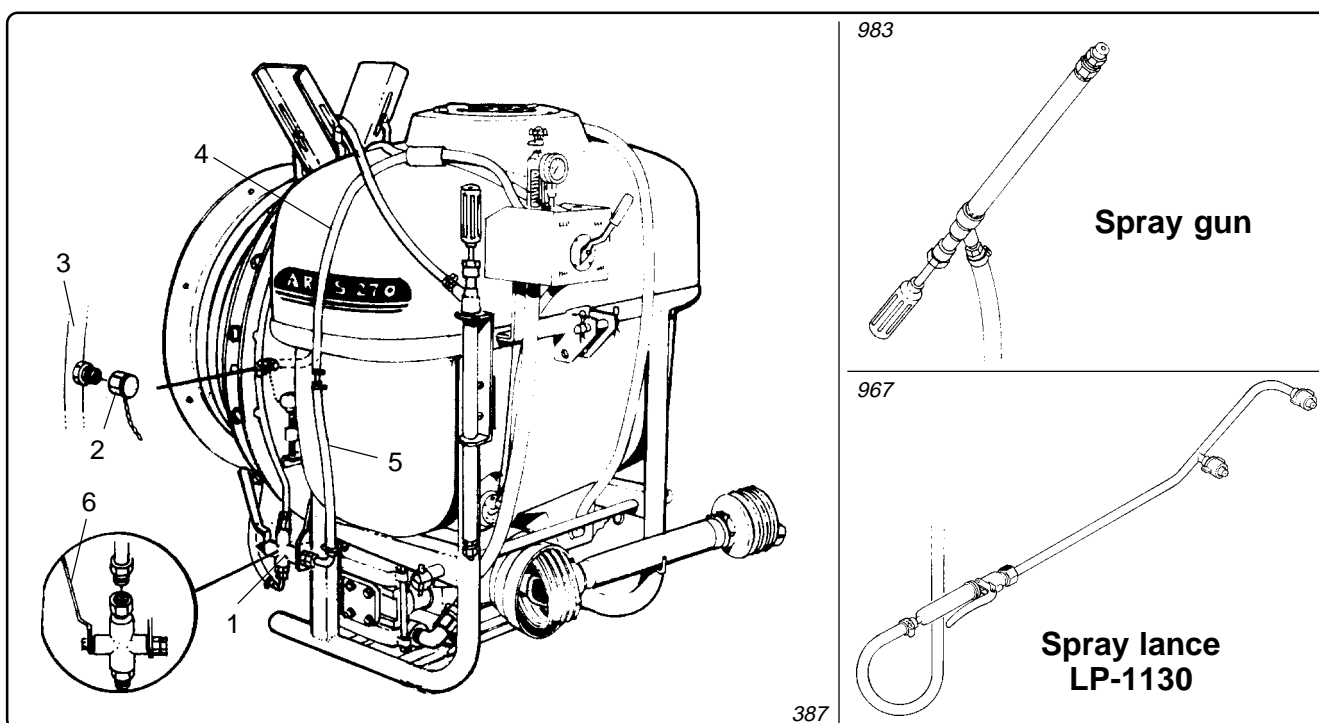

### ROW CROP HEAD (OPTIONAL)

- Remove the 3 upper sets of nozzles from the right and left nozzles branches.
- Take off the plugs from the nozzles branches on the row crop head and do the following: install said nozzles sets on the nozzles branches of the row crop head and fit the plugs on the sprayer's nozzles branches.
- Loosen the two stud bolts and two screws (1) on the deflector.
- Mount the row crop head on the sprayer's deflector and tighten the nuts.
- Connect the hoses of the deflector to the sprayer's application circuit.
- Adjust the nozzles according to the plants size.

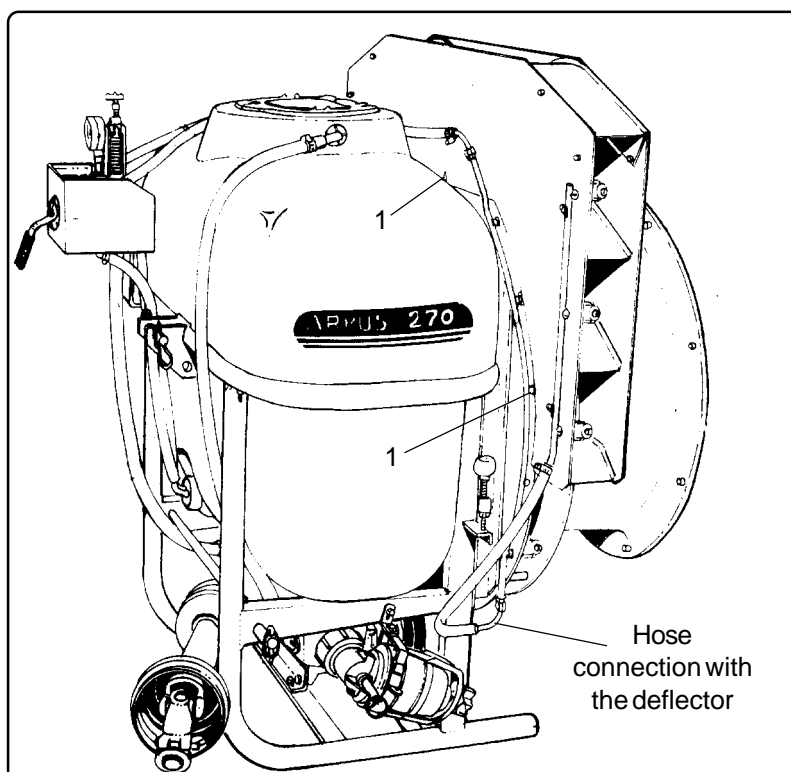

# MAIN COMPONENTS OF SPRAYER

## ONE-WAY VOLUTE (OPTIONAL)

This is an accessory designed to be used on applications requiring greater air volume; for instance, when spraying dense foliage.

### ASSEMBLING PROCEDURES:

- Remove the left nozzles branch from the sprayer.
- Mount the two supports (1) on the deflector.
- Push back the lower vane.
- Install the base of the volute and tighten the nuts (2).
- Mount the middle part of the volute and tighten the screws (3).
- Mount the adjustable end onto the middle part of the volute.
- Remove the upper set of nozzles of the right branch and replace it by the box nut installed on the volute nozzles branch.
- Adjust the volute according to the plants size and lock the four screws (4).
- Install the chemical mixture hose (5).
- Mount the vane inside the volute and tighten the screws.

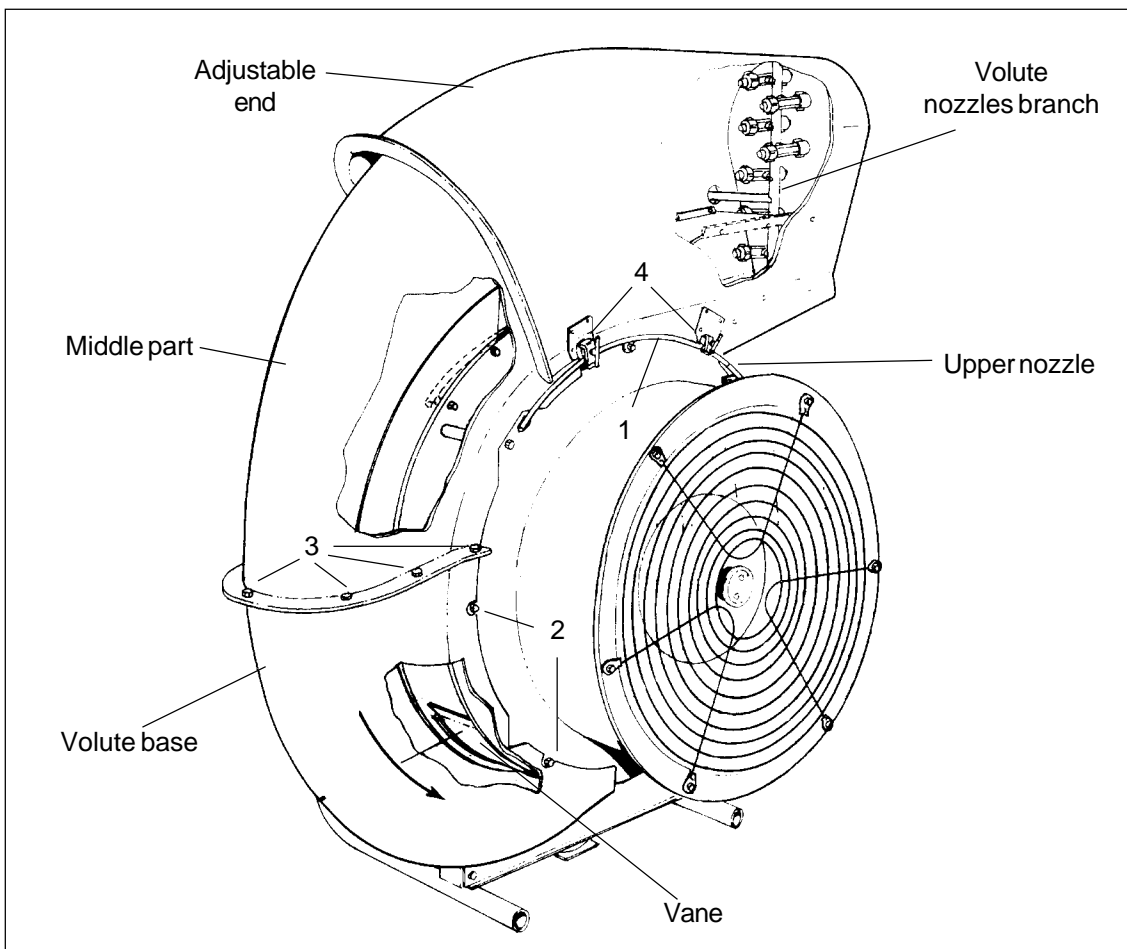

## OPERATIONAL PROCEDURES

Stage	Procedure	Sprayer type	
		Trailer	3 point
Spraying	Use individual protective clothing .....	X	X
	Do not work at high speeds .....	X	X
	Do not spray against the wind .....	X	X
	Do not travel with boom lifted or unlocked .....	X	X
	Take care with electricity supply cables .....	X	X
	Do not eat, drink or smoke while spraying .....	X	X
	After spraying, take off all protective clothing and take a shower .....	X	X
Receiving the sprayer	Check if all components are intact .....	X	X
	Check the components of accessories box .....	X	X
	Require trained person to instruct about assembling, operating and servicing components and accessories ...	X	X
Using the sprayer for the first time	Check if the hitch pin is original .....	X	-
	Check if the three-point hitch pins are original .....	-	X
	Check if the hitch pins have cotter pins .....	X	X
	Check the overlaps of the PTO shaft .....	X	X
	Remove the tractor's drawbar .....	-	X
	Raise to the highest the tractor's hydraulic arms .....	X	X
	Adjust the control valve position to avoid impacts while turning .....	X	-
	Check if the grease fittings are filled .....	X	X
	Check if the oil is on the level on the components .....	X	X
	Calibrate the tires .....	X	-
Retighten the tank nuts and lug nuts .....	X	-	
Whenever filling the tank	Clean the suction or line filters .....	X	X
	Clean nozzles and their strainers .....	X	X
Every day or every 10 hours	Clean nozzles, strainers and filters .....	X	X
	Check the grease fittings and joint pins .....	X	X
	Check the oil level on the pumps and gear box .....	X	X
	Wash the inside and outside of the sprayer .....	X	X
	Check for damage on the paint and repaint .....	X	X
	Check for oil leakage and stop it .....	X	X
First 30 hours	Change for the first time the pump oil .....	X	X
	Retighten the bolts on the tank, axle and wheels .....	X	-
Every 100 hours	Change the oil of the pump and gearbox .....	X	X
	Tighten the belts .....	X	X
	Clean and check the pressure regulator components ....	X	X
	Clean the inside and outside of the sprayer, and paint the parts subject to corrosion with a mixture of lubricating oil at 80% and diesel oil at 20% .....	X	X
Every 500 hours or annually	Service the pump .....	X	X
	Change hydraulic oil .....	X	-
	Change the oil of the gearbox .....	X	X
	Retighten the bolts of tank, wheels, axle, etc. ....	X	-
	Change the grease of the wheel hub .....	X	-

# CHOOSING THE IDEAL TRACTOR

## PROCEDURE

- Check the sprayer weight in the sprayer's identification plate.
- Check the capacity of the sprayer's tank.
- Check in the technical specifications table the total power consumption required.

Example:

- Sprayer weight = 181 kg
- Tank capacity = 270 liters
- Total power consumption = 11.9 HP

### 1- Considering the power consumption

The tractor's engine power must be at least 90% higher than the power required to run the sprayer.

Example:

- Power required by the sprayer = 11.9 HP
- **Tractor recommended: with minimum nominal power of 22.6 HP**

### 2- Considering the lift capacity of the hydraulic system

The lift capacity of the tractor's hydraulic system must be higher than empty sprayer weight added to the weight equivalent to the tank capacity.

Example:

- Empty sprayer weight ..... 181 kg
- Tank capacity ..... 270 l (approximately 270 kg)
- **Tractor recommended: with lift capacity of hydraulic system higher than 451 kg.**

## ATTENTION

**The figures above are specifically mentioned in order to direct you on how to proceed to choose the ideal tractor to which you are to mount your sprayer.**

# SETTING UP TRACTOR

## ADJUSTING PARTS TO HITCH TO THE TRACTOR'S THREE-POINT SUSPENSION

**ATTENTION:** The instruction below is an example of what should be done for properly hitching the sprayer to the tractor's three-point suspension. To exemplify we have used the Ford 4600 tractor. However, you should proceed as directed in the operator's manual of your tractor.

### TIE ARM OF THE LEFT BAR

To adjust the length of the left lift arm to the proper position, loosen the pin and turn the lower half (2) of the lift arm.

**NOTE:** The grease fitting (1) should point up.

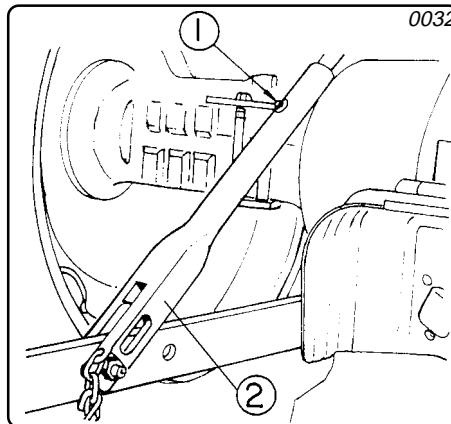

### LEVELLING BOX

To adjust the transversal levelling of the sprayer, turn the crank (1) located on the levelling box.

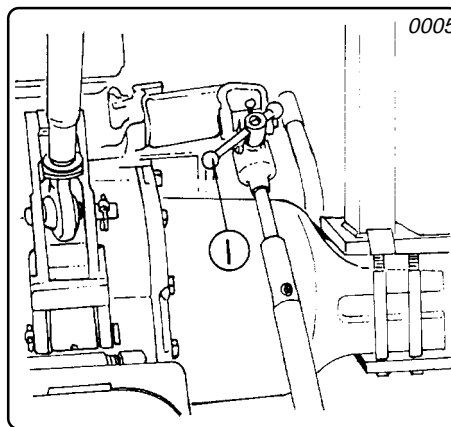

### ADJUSTING THE THIRD POINT

Release the lock (1) and turn the sleeve (2) to adjust the length of the third point arm. During transport, fasten the plate of the third point bar to the pin (3) of the frame.

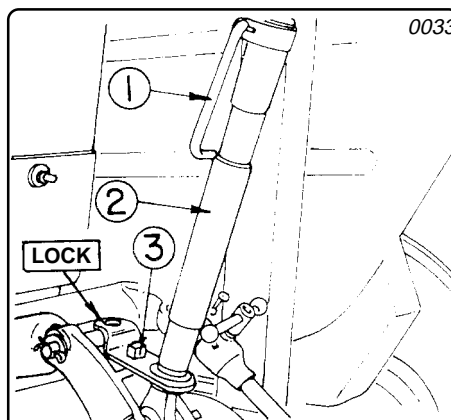

# SETTING UP TRACTOR

## ADJUSTING PARTS TO HITCH TO THE TRACTOR'S THREE-POINT SUSPENSION

### THIRD POINT FRAME

The third point frame has two positions (1 and 2) to install the third arm and two positions (3 and 4) to install the frame lower pin.

Thus there are four different positions for this assembly.

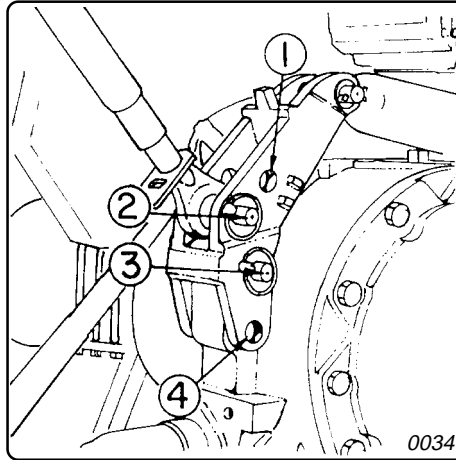

### HOLES POSITION

The positions of the holes vary according to the duty to be done.

Third arm's position	Frame	Duty kind
No. 1	No. 4	Ultra-light
No. 1	No. 3	Light
No. 2	No. 4	Medium
No. 2	No. 3	Heavy

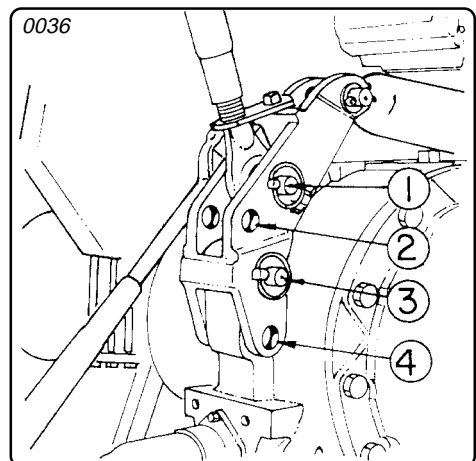

### STABILIZING CHAINS

The stabilizing chains should be installed to limit the lateral movement of the sprayer hitched to the three-point system.

These chains should be adjusted according to the boom of the sprayer to be used. To adjust them, relieve the lock nut (1) and turn the adjusting nut (2), as necessary, and retighten the lock nut.

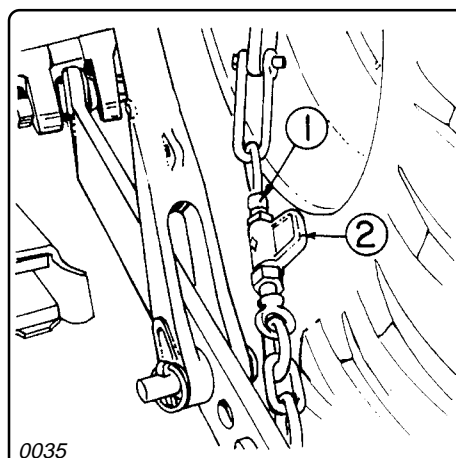

## MOUNTING THE SPRAYER TO THE TRACTOR

- Remove or pull the tractor's drawbar aside.

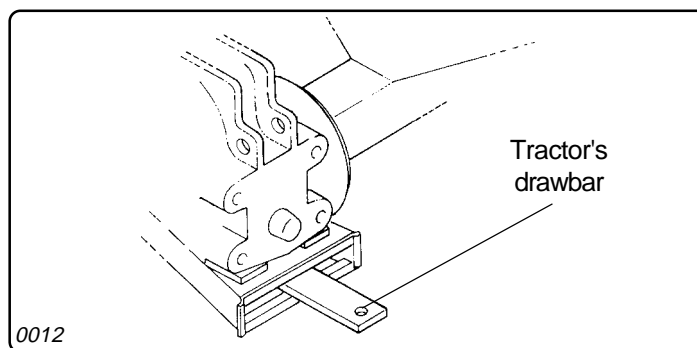

- Mount the sprayer to the tractor's three-point suspension and level it as shown in the figure beside.

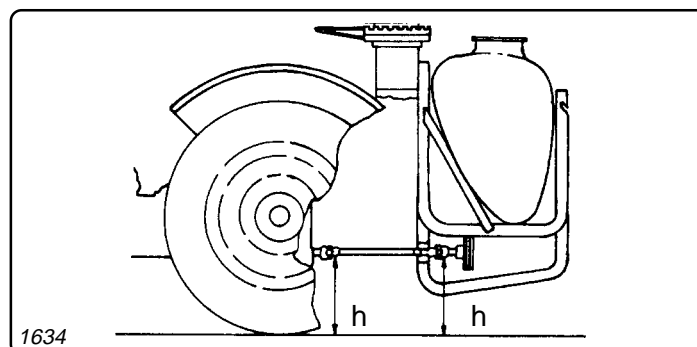

- Adjust the tractor's hydraulic lift lever so that the sprayer is not raised too high.

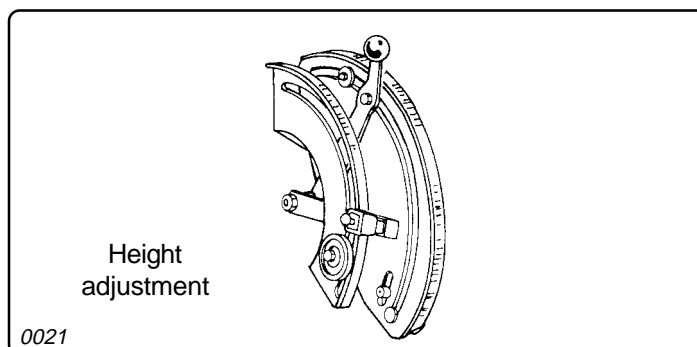

- Adjust the PTO shaft. If necessary, cut the male and female tubes so that, after connecting the sprayer, it has the overlaps recommended in the figure beside.

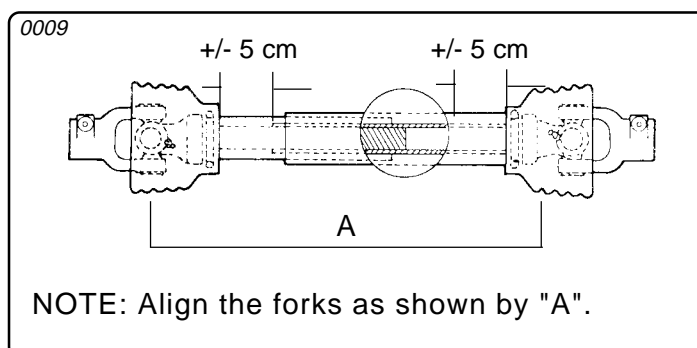

### ATTENTION

Before cutting the tubes, check for all possibilities of movement of the sprayer on the lift arms and third point.

Make sure the hitch pins locks are correctly installed.

For instructions in detail, refer to the section MAINTENANCE - PTO SHAFT.

# OPERATION AND ADJUSTMENTS

## SPRAY APPLICATION TECHNOLOGY

A successful spray application does not depend only on a good sprayer or correct use of the chemicals but also on factors to be determined in the field under specialized orientation.

Among these factors, some concepts should be part of a criterion of evaluation so that positive results may be attained within the pest control program.

- **Ideal time**
- **Safety**
- **Sprayer operational condition**
- **Application rate**
- **Good coverage**
- **Well trained operator**

### IDEAL TIME

The ideal time for spraying should be chosen according to the chemical product characteristics, as well as to the field conditions:

- Infestation level of pests, diseases and weeds;
- Infection level of diseases;
- Growing stage of weeds;
- Weather conditions.

### SAFETY

When spraying your crops, you must make sure there will be no risk to people, animals and environment. Avoid spraying at hotter times, with humidity below 55% or under windy conditions. **Do not allow the operator to handle chemicals and spraying machinery without the proper individual protective clothing.**

### CORRECT APPLICATION RATE

Any type of application requires that the rate be maintained during the whole spraying work. This will be possible when you have a good sprayer properly calibrated.

This calibration can be obtained through practical methods or formulas. Please refer to the section **OPERATION AND ADJUSTMENTS - CALIBRATING THE SPRAYER.**

### GOOD COVERAGE

You have a good coverage when the whole target is sprayed with uniform distribution, with no risk to the environment and with good results in the pest control.

The application rate does not have influence on the treatment results. Therefore good coverages can be attained even with different rates, which may vary according to operational and regional factors.

### IMPORTANT!

**READ CAREFULLY AND FOLLOW STRICTLY THE INSTRUCTIONS ON THE CHEMICALS MANUFACTURER'S LABEL.**

**ALWAYS FOLLOW DIRECTIONS OF A TECHNICIAN WHEN HANDLING AND APPLYING CHEMICALS.**

**ALWAYS MAKE SURE THE SPRAYER IS IN GOOD OPERATIONAL CONDITIONS BEFORE STARTING THE SPRAYING JOB AND EMPLOY A WELL TRAINED OPERATOR.**

# OPERATION AND ADJUSTMENTS

## HOLLOW CONE NOZZLE HIGH QUALITY CERAMIC SERIES JA

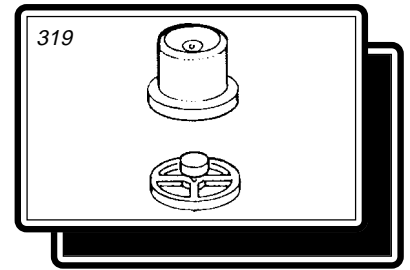

### TECHNICAL CHARACTERISTICS

SPRAY PATTERN ..... HOLLOW CONE  
 SPRAY ANGLE ..... 75 TO 80 DEGREES AT 150 PSI  
 MATERIAL DE FABRICAÇÃO ..... **SINTERED ALUMINA**  
 FLOWRATE IDENTIFICATION ..... NOZZLE COLOR AND DESCRIPTION

The hollow cone nozzles of Series JA are produced by processes developed for exacting markets of mechanical engineering, space and aerospace industries. A special mold injection process makes a perfect orifice on the nozzles, giving better quality to the surface finish than that achieved by machines. And the result is better coverage and more homogenous spraying.

These nozzles are approved by international quality standards, ensuring an outstanding spray cone uniformity and flow rate of nozzles.

The alumina-sintered nozzles are almost as hard as diamond and resist yet the most corrosive products. This provides perfect stability for long time concerning all requirements such as flow rate, coverage and droplet size.

### FLOW RATE TABLE

Pressure (psi)	Nozzle model					
	JA - 1	JA-1.5	JA-2	JA-3	JA-4	JA-5
	Flow rate (l/min)					
<b>30</b>	0.23	0.31	0.47	0.64	0.91	1.16
<b>45</b>	0.28	0.38	0.55	0.77	1.10	1.40
<b>60</b>	0.32	0.43	0.64	0.88	1.25	1.60
<b>90</b>	0.38	0.52	0.76	1.06	1.51	1.93
<b>120</b>	0.42	0.59	0.86	1.21	1.72	2.20
<b>150</b>	0.50	0.66	1.00	1.34	1.91	2.44
<b>180</b>	0.52	0.71	1.04	1.46	2.07	2.65
<b>210</b>	0.55	0.77	1.13	1.57	2.22	2.85
<b>240</b>	0.60	0.82	1.22	1.68	2.34	3.22
<b>270</b>	0.63	0.87	1.28	1.76	2.42	3.41
<b>300</b>	0.72	0.90	1.42	1.84	2.54	3.57

**NOZZLES STRAINERS:** Use 50 or 60 mesh for all nozzle models.

Color	Blue	Brown	Black	Orange	Red	Green
Model	JA - 1	JA - 1.5	JA - 2	JA - 3	JA - 4	JA - 5
Part #	109744	454256	000026	454264	454272	454280

**ORDERING:** Specify nozzle model and part #. Ex: JA - 2; part # 000026.

# OPERATION AND ADJUSTMENTS

## HOLLOW AND FULL CONE NOZZLES - SERIES J

### HIGH QUALITY CERAMIC. HIGH RESISTANCE TO WEAR.

The alumina-sintered nozzles are almost as hard as diamond and resist yet the most corrosive chemicals. This ensures perfect stability for long time besides meeting the requirements for flow, coverage and droplet size.

These nozzles are recommended for fruit trees because of their excellent performance in high volume spraying.

**NOTE:** As there are many options for row spacing and number of nozzles per branch, we do not list any table showing the spraying volume as it can be obtained through the formula specified in the section OPERATION AND ADJUSTMENTS - CALIBRATING THE SPRAYER.

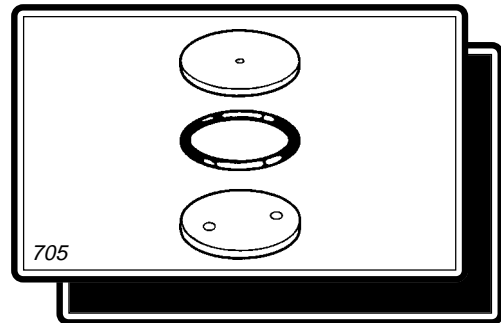

### FLOW RATE TABLE

Nozzle model	Pressure (psi)							
	75	100	150	200	250	300	350	400
	Flow rate (L/min)							
J4-2 hollow cone	1.07	1.21	1.48	1.70	<b>1.90</b>	<b>2.07</b>	<b>2.23</b>	<b>2.39</b>
J4 - 3 full cone	1.56	1.81	2.21	2.55	<b>2.86</b>	<b>3.14</b>	<b>3.38</b>	<b>3.61</b>
J5 - 2 hollow cone	1.56	1.82	2.22	2.54	<b>2.63</b>	<b>3.10</b>	<b>3.34</b>	<b>3.57</b>
J5 - 3 full cone	2.65	3.05	3.69	4.28	<b>4.77</b>	<b>5.22</b>	<b>5.63</b>	<b>6.03</b>
J6 - 2 hollow cone	2.26	2.63	3.21	3.68	<b>4.12</b>	<b>4.50</b>	<b>4.83</b>	<b>5.16</b>
J6 - 3 full cone	4.42	5.07	6.19	7.15	<b>7.99</b>	<b>8.73</b>	<b>9.41</b>	<b>10.06</b>

Pressure band not recommended because it will cause premature wear to nozzles.

### ORDERING

Nozzle model	J4 - 2	J4 - 3	J5 - 2	J5 - 3	J6 - 2	J6 - 3	Ring
Part #	325423	819607	325431	327486	325449	327494	913335

**Specify nozzle model and part #. Ex: J5-2, part # 325431.**

# OPERATION AND ADJUSTMENTS

## CALIBRATING THE SPRAYER

The safety of people, animals and environment depends on correct spray applications. Therefore, we list below some operational procedures.

### WHEN HANDLING AGROCHEMICALS

- Follow strictly the instructions on the labels.
- Use individual protective clothing.
- Do not eat, drink or smoke.
- Choose a ventilated place.
- Wash with water and soap the parts of the body touched by chemicals.

### WHEN HANDLING THE SPRAYER

- Check for the proper working conditions of the sprayer.
- Do not blow by mouth nozzles, valves or tubes.
- Do not spray against the wind.
- Do not spray at sunny times.
- Use individual protective clothing recommended.
- Do not eat, drink or smoke.

### REMEMBER

**You are responsible for the success of the application.**

The sprayer can be calibrated by calculating the spray volume through the following formula:

$$V = \frac{F \times 600}{S \times A} \text{ (L/ha)}$$

Where:

V : Spray volume (L/ha)

F : Nozzles total flow rate (L/min)

S : Tractor speed (km/h)

A : Row spacing (m)

600 : Conversion unit

### EXAMPLE

**Nozzles total flow rate : 10 l/min (10 x JA-2 nozzles at 150 psi)**

**Row spacing : 4 m x 3 m**

**Plants per hectare : 833 plants**

$$V = \frac{F \times 600}{S \times A} \text{ (L/ha)} \quad V = \frac{10 \times 600}{4 \times 4} \text{ (L/ha)} \quad V = \frac{6,000}{16} = 375 \text{ L/ha}$$

$$\text{SPRAY VOLUME PER PLANT: } \frac{375}{833} = 0,45 \text{ L/plant}$$

# OPERATION AND ADJUSTMENTS

## DILUTING THE CHEMICALS

### ATTENTION

**NEVER** run the sprayer for with less than 50 liters of water in the tank to avoid damage to the pump.

Always use the following individual protective clothing when handling chemicals:

- Impermeable wide-brimmed hat
- Goggles
- Mask
- Long-sleeved working clothes
- Impermeable gloves
- Impermeable boots

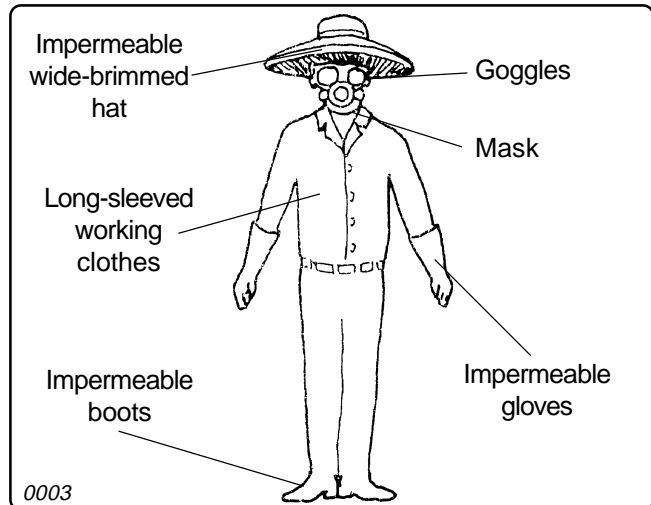

## PREPARING THE CHEMICAL MIXTURE

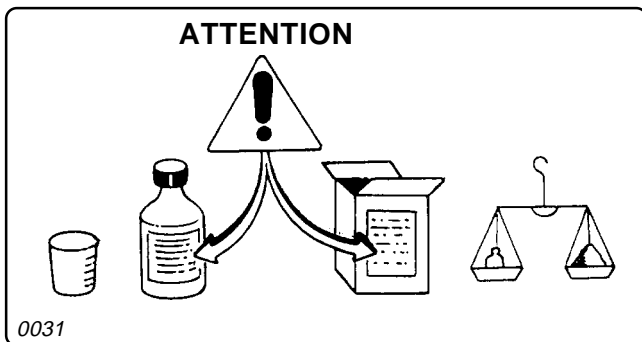

- Read carefully the chemicals manufacturer's label.

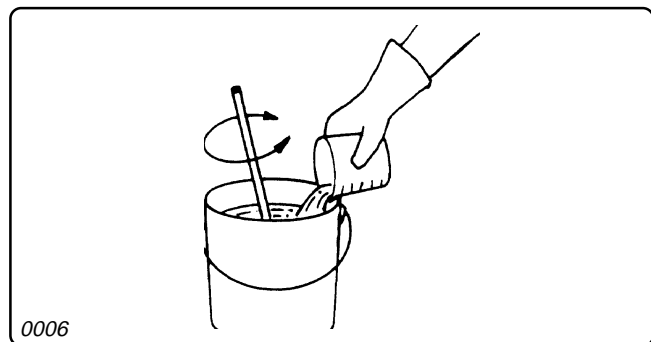

- Pour the chemicals into a bucket with little water and stir.

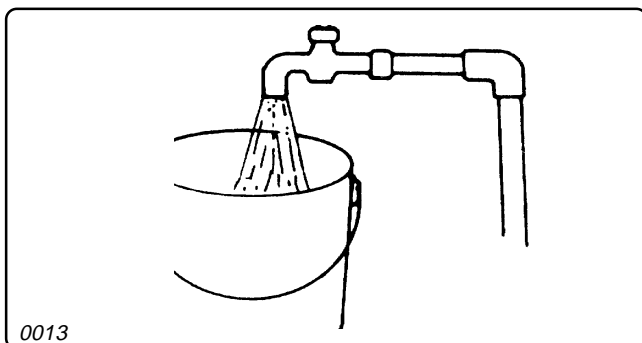

- Add water until filling the bucket up.  
- Stir until the mixture is homogeneous.

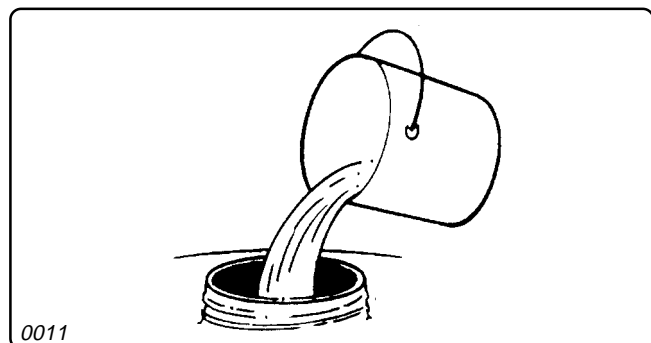

- Pour the solution into the sprayer's tank.  
- Install the tank lid and make sure there is no leakage.

**ATTENTION**  
**ALWAYS FOLLOW TECHNICAL RECOMMENDATIONS**  
**WHEN HANDLING CHEMICALS.**

# MAINTENANCE

## GUIDELINES

After the first working hours, check if the bolts, nuts, clamps on the tanks, wheel and axle are well installed. Retighten them if necessary.

Daily, after finishing the spray application, put clean water in the tank, remove the nozzles and run the sprayer till empty.

Clean and reinstall the nozzles.

Clean the main filter.

Rinse off the inside and outside of the sprayer.

## ATTENTION

**NEVER WASH SPRAYERS OR INDIVIDUAL PROTECTIVE EQUIPMENT IN OR CLOSE TO RIVERS, LAKES, STREAMS, BROOKS, DAMS, ETC.**

Take off and wash the individual protective clothing separated from other clothes.

Take a shower with plenty of water and soap and change your clothes.

These procedures will avoid future problems caused by strainer, nozzle and tube obstructions and prolong the sprayer's life, as well as protect yourself.

## COMPONENTS

### MAIN FILTER

The frequency of filter cleaning will depend on the quality of water and type of agrochemicals applied.

Clean the filter whenever filling the tank or when necessary.

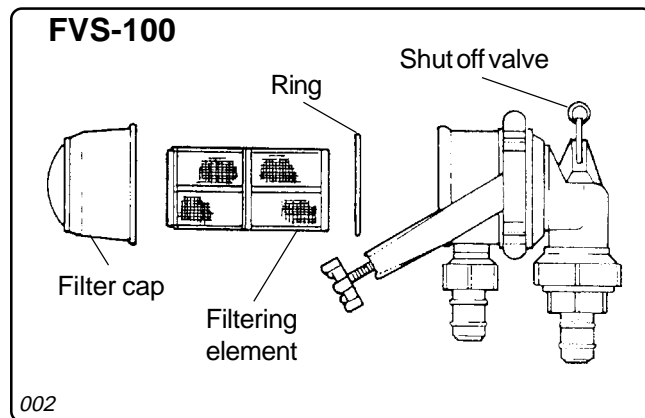

### NOZZLE HOLDER

Clean the nozzle holders daily or when necessary.

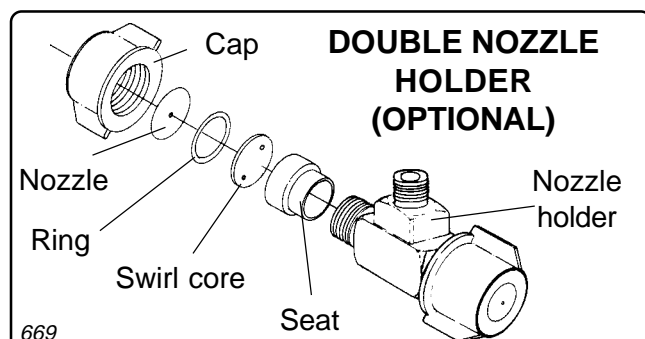

### VAR CONTROL VALVE

Disassemble the control valve every 100 working hours.

Check for wear on the valve and valve seat.

Replace the parts if necessary.

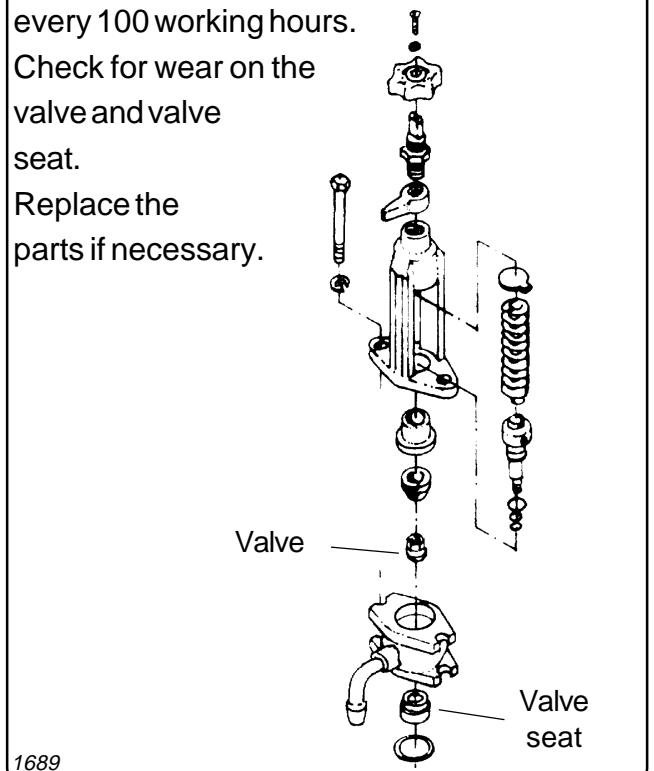

### NOZZLE HOLDER WITH VALVE

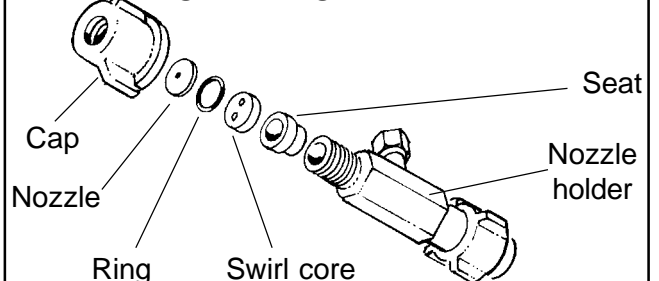

# MAINTENANCE

## LUBRICATION TABLE

PRODUCT	LOCATION	QTY	FREQ	SPECIFICATIONS	RECOMMENDED PRODUCTS
LUBRICATING OIL	JP-50 PUMP (*)	1.5 l	1ST CHANGE: AFTER 30 HOURS	API - SB OR SUPERIOR SAE - 30	ALL OILS FOR INTERNAL COMBUSTION ENGINES WITHIN THIS SPECIFICATION
	JP-75 PUMP	1.5 l	FURTHER CHANGES: EVERY 100 HOURS		
	JP-100 PUMP	2.0 l			
GREASE	PTO SHAFT	-	DAILY	LITHIUM BASE NGLI - 2	MULTIFAKE P-2 MOBIL GREASE 77 LUBRAX GMA-2 BEACON EP-2 AND SIMILAR PRODUCTS

(\*) This sprayer is equipped with the JP-50 pump.

**NOTE:** The presentation order of recommended products does not imply any preference for any brand or product.

### COMPONENTS LUBRICATION

#### PUMP

- Check the pump oil level daily and fill it if necessary.

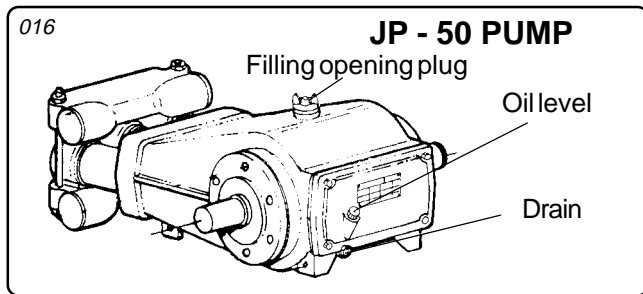

#### PTO SHAFT

- Lubricate the PTO shaft tubes.

For instruction in detail, refer to the section MAINTENANCE - PTO SHAFT.

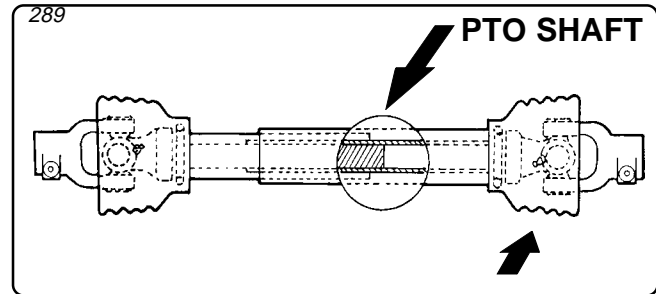

### BELT TENSION

Check the belt tension periodically as shown in the figure below. When pressed it should deflect as indicated.

#### FAN BELT: 10 to 15 mm

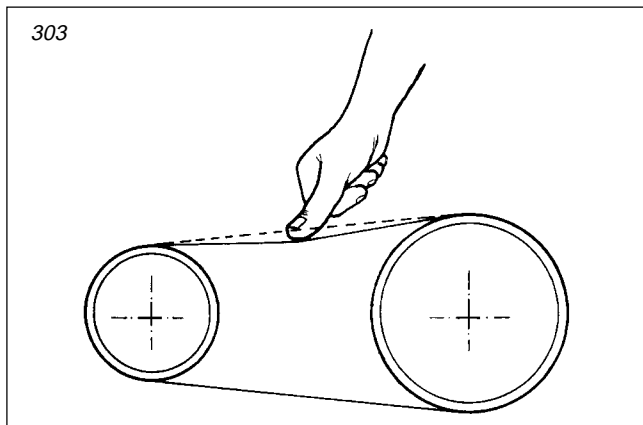

#### PROCEDURE

- Loosen the four screws (1).
- Loosen the four nuts (2).
- Tighten by hand at the same time the two knobs (3) until obtaining the recommended tension.
- Retighten the nuts (2) and screws (1).

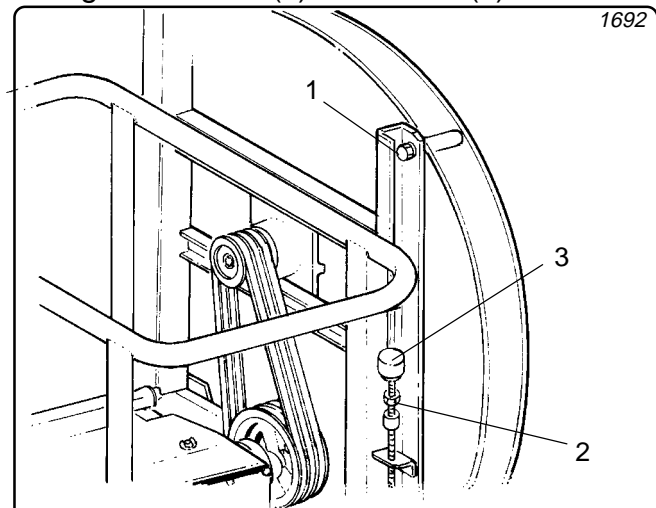

**ATTENTION:**  
ALWAYS STOP THE SPRAYER AND  
TURN OFF TRACTOR'S ENGINE  
BEFORE ANY KIND OF  
MAINTENANCE.

# MAINTENANCE

## CONVENTIONAL PTO SHAFT

**ATTENTION: ALWAYS STOP THE SPRAYER AND TURN OFF THE TRACTOR'S ENGINE BEFORE SERVICING THE PTO SHAFT.**

### 01-CONNECTING

- Check the PTO shaft length.
- Adjust the length by cutting the tubes and protection guards proportionately.

Note: File and remove all burrs.

- Lubricate the male and female tubes.

- Connect the PTO shaft and install the safety chain.

Note: Leave some slack on the chain considering angular movements.

- Disengage the PTO when making sharp turns.

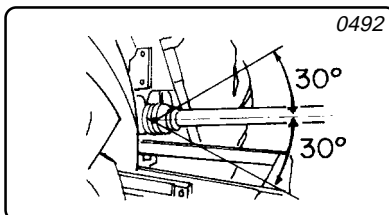
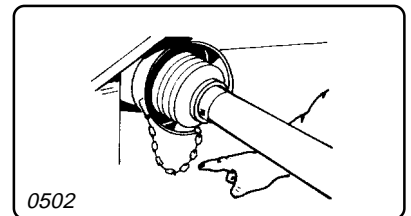
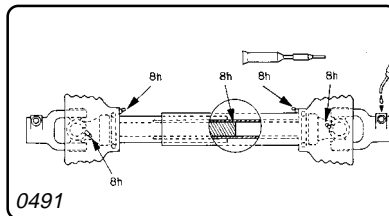
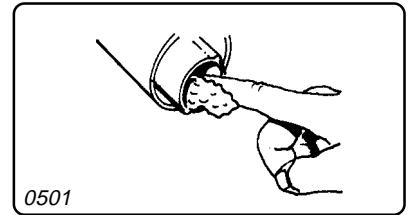
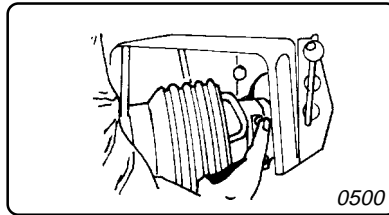

**ATTENTION**  
ONLY OPERATE WITH  
PTO SHAFT EQUIPPED  
WITH PROTECTION  
GUARDS.

### 02-SERVICING

#### a)DISASSEMBLING

- 1- Remove the lock screw.
- 2- Turn the guard cone until the indicated position.
- 3- Pull the guard cone.
- 4- Remove the sliding ring.

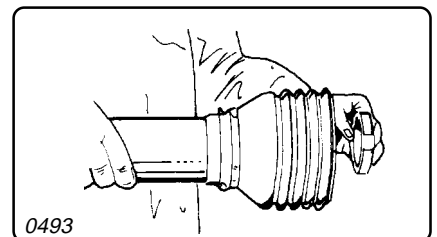
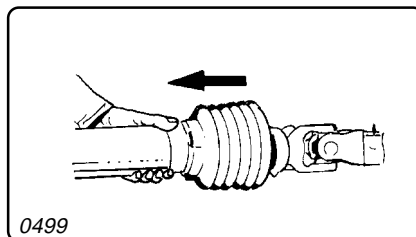
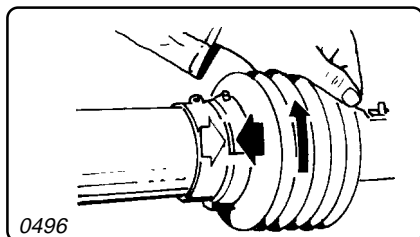
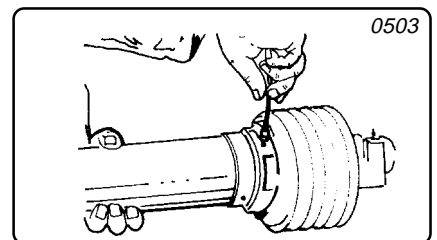

#### b)ASSEMBLING

- 5- Clean and lubricate the male and female tubes.
- 6- Install the sliding ring into the fitting with the grooves pointing toward the tube.
- 7- Install the protection guards.

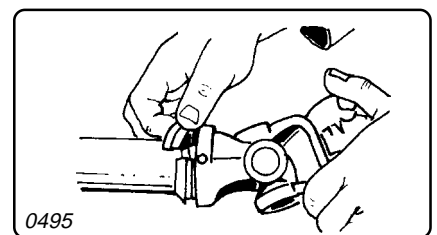
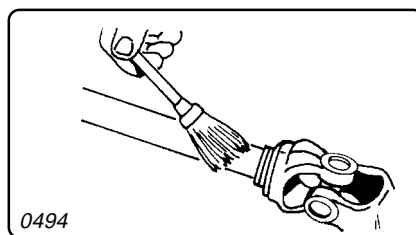

- 7- Install the protection guards.

- 8- Turn the guard cone until the indicated position.

- 9- Install the lock screw.

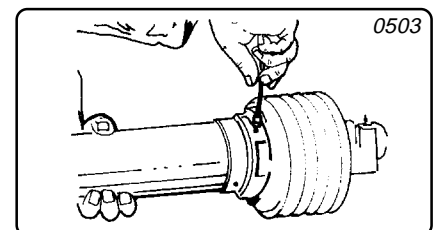
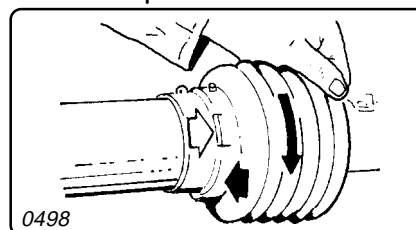
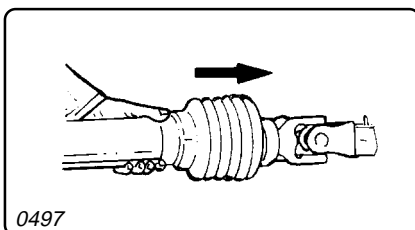

# MAINTENANCE

## DECALS

Jacto sprayers have several decals aiming to direct on the use and maintenance as well as to warn about dangerous and damageous locations and procedures.

Keep them in place because they are important for the operator and people working and standing around the sprayer.

Item	Part #	Description	Qty
01	013169	TESTE FINAL (Port./Eng./Sp.)	01
02	332247	CAUTION (Sp./Eng.)	01
03	222216	620	01
04	515734	LIMPAR O FILTRO... (Port./Eng./Sp.)	01
05	130641	ATENCIÓN (Sp.) ["Attention"]	01
06	019356	MANTER O ÓLEO NO NÍVEL...	01
07	428631	INSTRUCTIONS ON PTO SHAFT (Port./Sp./Eng.)	01
08	039396	CARE WITH PTO SHAFT (Port./Eng./Sp.)	01
09	360248	VENTILADOREM ALTA ROTAÇÃO... (Port./Eng./Sp.)	01
10	360255	É NECESSÁRIO USO DO PROTETOR.... (Port./Eng./Sp.)	01
11	018705	DESTRAVE DO VENTILADOR (Port./Eng./Sp.)	01
12	222919	JACTO LOGO	01
13	225748	"ARBUS 270"	01

**ATTENTION**  
**REPLACE THE DECALS IN CASE OF DAMAGE OR ILLEGIBILITY.**  
**YOU MAY ORDER THEM THROUGH THE PART NUMBERS**  
**SPECIFIED ABOVE.**

# MAINTENANCE

## WINTER STORAGE

**ATTENTION:** In regions where temperatures drop to 0°C or less, the water accumulated in the pump can freeze and cause serious damage.

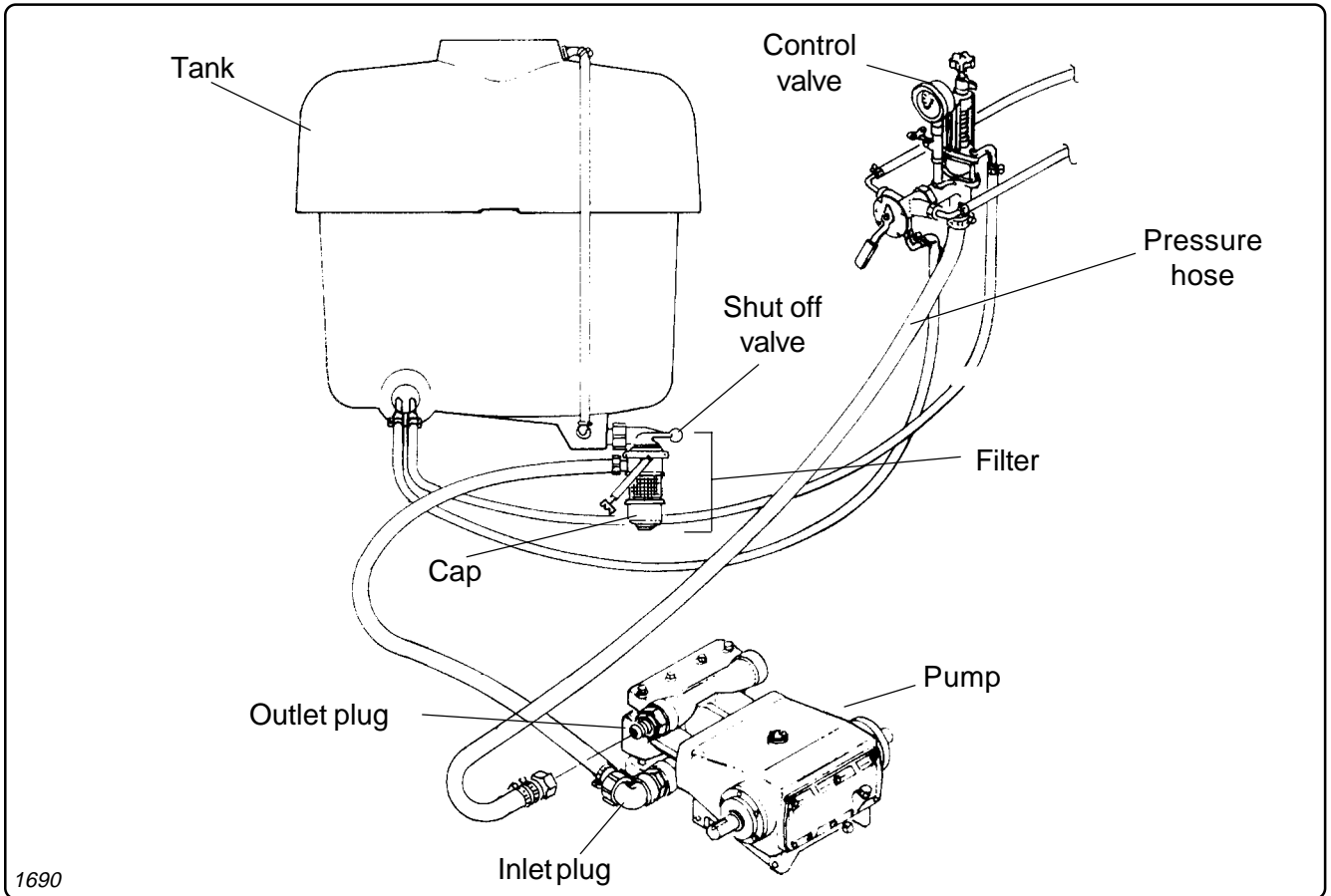

## PROCEDURES

- Empty the tank completely by removing the drain plug.
- Remove the filter cap and open the filter valve.
- Disconnect the pressure hose from pump or remove the outlet plug from the valve cover.
- Run the sprayer for about 30 seconds at half speed.

**NOTE:** To avoid damage, do not run the sprayer over the recommended time.

- Assemble the components again in their correct place.
- Repeat this operation at the end of each daily spray application during the winter.

# MAINTENANCE

## TROUBLE-SHOOTING

### COMPONENTS:

- Tank
- Main filter
- Control valve
- Pump
- Pressure hose
- Return hose
- Nozzles

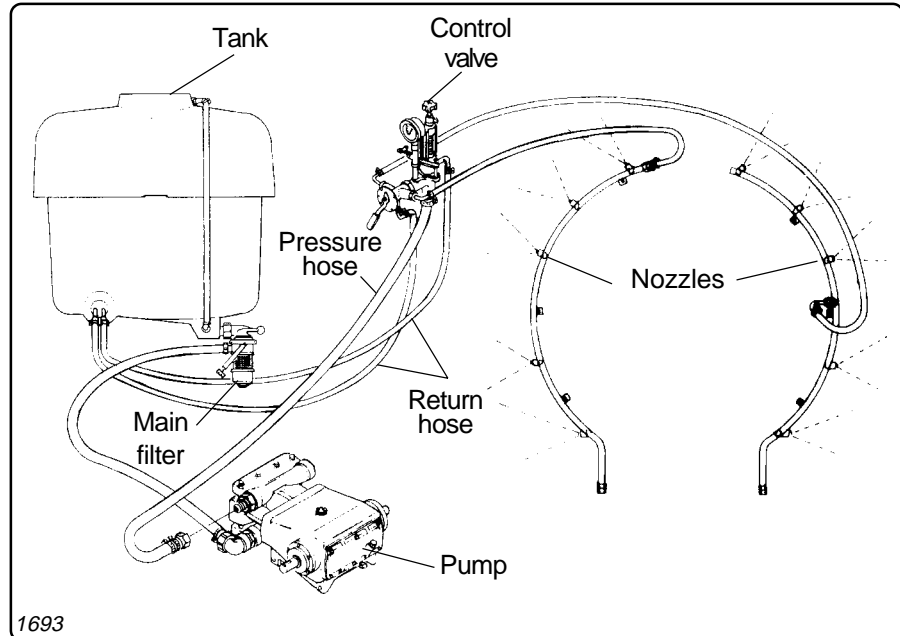

### PROBLEMS - CAUSES - SOLUTIONS

Whenever Jacto sprayers equipped with piston pumps present problems, try to classify them in one of the following four groups.

#### a) LACK OF SUCTION AND PUMPING CAPACITY

No liquid flow through the nozzles.  
 No return to the tank.  
 Pressure gauge does not indicate pressure.

#### b) PRESSURE DEFICIENCY

(PARTIAL LACK OF PRESSURE)  
 Desired pressure is not attained.  
 Specified nozzle spraying angle is not attained.  
 Pressure gauge shows lower pressure.

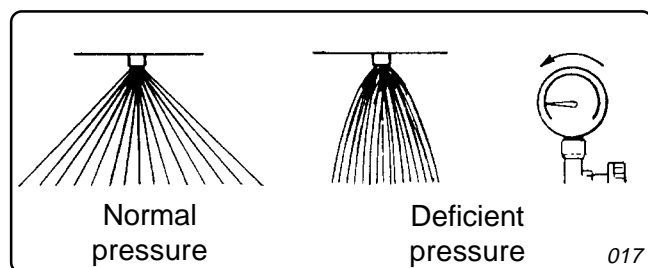

#### c) PRESSURE OSCILLATION

The pressure gauge needle oscillates.  
 The nozzle spray angle oscillates.

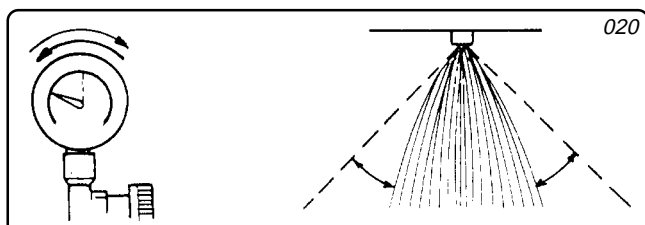

#### d) INTERMITTENT PRESSURE

The pressure gauge needle vibrates with intensity.  
 The pressure hoses vibrate with intensity.  
 The nozzles spray angle varies.

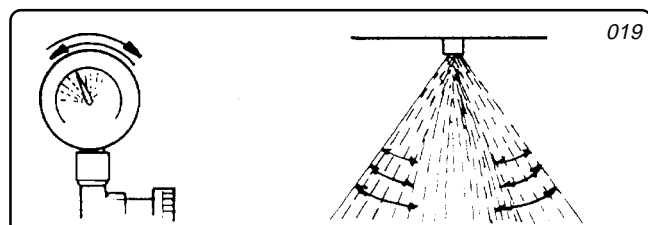

# MAINTENANCE

## TROUBLE-SHOOTING

### a - LACK OF SUCTION AND PUMPING CAPACITY

PROBABLE CAUSES	SOLUTIONS
1- PTO not turning.	The sprayer should be run with 540 rpm at PTO. Check visually whether the pump is being run.
2- Lack of water in the tank.	To run the hydraulic system, it is necessary to contain a minimum quantity of liquid, otherwise there will be no pressure.
3- Filter shut off valve closed.	When the pump runs, liquid will pass through the valve even in the closed position, however it will be insufficient. Open it.
4- Dirty filter.	Impurities in the filter prevent a free liquid flow. Clean the filter whenever filling the tank, or with more frequency depending on the quality of the water and the type of product applied.
5- Obstruction in the intake hoses.	Check whether the hose connecting the filter to the pump is twisted. Check whether there is any obstruction in the hoses from tank to filter. Fill up the tank with water, open the valve and verify if it flows freely.
6- Air in the system.	Check the filter packing ring. The filter should not leak.
7- Insufficient pump suction.	

### b - PRESSURE DEFICIENCY

PROBABLE CAUSES	SOLUTIONS						
1- Low PTO rpm.	The proper PTO rotation is 540 rpm.						
2- Filter shut off valve closed.	When the pumps runs, liquid will pass through the valve even in the closed position, however flow will be insufficient.						
3- Filter partially obstructed.	The filter should be clean to allow free liquid flow.						
4- Intake hose partially obstructed.	A deficient pump will cause depressurization. Check whether the hose connecting the filter to the pump is twisted. Verify whether there is any obstruction in the hoses connecting the tank to the filter. Fill the tank with water, open the valve and observe if it flows freely.						
5- Air in the system.	Check the connections and the o'rings of the tank outlet and the pump inlet.						
6- Pressure regulator.	Check the valve and valve seat.						
7- Worn nozzles.	Check whether the nozzle flow is within the recommended guidelines. Replace the nozzles when the flow rate exceeds 10% of the specified. Use only nozzles recommended by the sprayer manufacturer.						
8- Pump with lower flow rate.	Disconnect the pressure hose from the control valve. Run the sprayer at 540 rpm. Collect water for one minute and measure. The volume collected should approximate this shown below for each pump model: <table style="width: 100%; border: none;"> <tr> <td style="width: 50%;">JP - 402 = 38 L/min</td> <td style="width: 50%;">JP - 100 = 100 L/min</td> </tr> <tr> <td>JP - 42 = 42 L/min</td> <td>JP - 150 = 150 L/min</td> </tr> <tr> <td>JP - 75 = 75 L/min</td> <td>JP - 300 = 300 L/min</td> </tr> </table>	JP - 402 = 38 L/min	JP - 100 = 100 L/min	JP - 42 = 42 L/min	JP - 150 = 150 L/min	JP - 75 = 75 L/min	JP - 300 = 300 L/min
JP - 402 = 38 L/min	JP - 100 = 100 L/min						
JP - 42 = 42 L/min	JP - 150 = 150 L/min						
JP - 75 = 75 L/min	JP - 300 = 300 L/min						

# MAINTENANCE

## c - PRESSURE OSCILLATION

PROBABLE CAUSES	SOLUTIONS
1- Loose belts.	Check belt tension and tighten if necessary.
2- Air in the intake system.	Check for damaged hoses, filter packing rings, etc., and repair if necessary.
3- Pressure regulator.	Check the regulator components and clean or replace them if necessary.

## d - INTERMITTENT PRESSURE

PROBABLE CAUSES	SOLUTIONS
1- Filter shut off valve closed.	When the pumps runs, liquid will pass through the valve even in the closed position, however flow will be insufficient.
2- Pump valve deficiency.	Valve with sealing deficiency or stuck due to impurities.

# GENERAL CARE

## HANDLING AGRICULTURAL SPRAYERS AND CHEMICALS

We warn the owners and users that the UNREASONABLE USE of this sprayer and chemicals applied may cause damage to people, properties, animals and environment.

Read carefully and understand thoroughly this manual and the recommendations of the chemicals manufacturers.

Follow strictly the instructions for proper use of this sprayer and chemicals to ensure more safety and efficiency when spraying your crops.

## AFTER SPRAYING

**ATTENTION:** Avoid leaving chemical mixture residues in the tank. For the last pass, prepare the chemical solution in enough quantity to spray the remaining of the crop.

- Empty completely the tank and wash thoroughly the sprayer in a proper decontamination place.
- Wash the inside and outside of the sprayer with clean water and detergent.
- Disassemble and clean each nozzle assembly with fine brush, water jet or compressed air.
- Dry, lubricate and store the sprayer in a dry and covered place.
- Repaint the damaged metallic parts to prevent corrosion.
- Spray the mettalic parts with a mixture of lubricating oil at 80% and diesel oil at 20% to prevent corrosion.
- Take off and wash the individual protective clothing separately from other clothes.

### DANGER

#### SAFETY OBSERVATION

**OPERATING THIS SPRAYER WITHOUT FOLLOWING THE INSTRUCTIONS  
MAY RESULT IN SERIOUS INJURY OR DEATH.**

# STATEMENT OF LIMITED WARRANTY

MÁQUINAS AGRÍCOLAS JACTO S.A. warrants the equipment described herein and agrees to repair or replace parts and components which, under normal operation and wear, following the technical recommendations, show DEFECTS IN MATERIAL OR WORKMANSHIP.

## **WARRANTY PERIOD:**

- One (1) year from the purchase date by the original retail purchaser.

## **WARRANTY APPLICATION:**

Jacto or its authorized representative shall honor this warranty, if any part or component shows confirmed defect in workmanship.

IT SHALL BE UNDERSTOOD THAT THE REPLACEMENT OF COMPLETE COMPONENTS SUCH AS PUMPS, CONTROL VALVES, ENGINES, TRANSMISSIONS, HYDRAULIC PISTONS AND SIMILAR ONES SHALL ONLY BE PERFORMED IN CASE THAT THE DEFECT CANNOT BE REPAIRED BY REPLACING PARTS AND/OR PIECES OF THE COMPONENT.

## **THIS WARRANTY IS NULL AND VOID IF:**

- Equipment is not used in accordance with the INSTRUCTION MANUAL, overwork or accidents.
- Improper preventive maintenance or performed by unauthorized people.
- Modification of the equipment in any way from the original design.
- Change, damage, or loss of the product identification plate.
- Utilization of parts and components not supplied by JACTO.

PRODUCT REGISTRATION CARD MUST BE COMPLETED BY THE ORIGINAL RETAIL PURCHASER, AND RETURNED TO JACTO DEALER WITHIN 30 DAYS OF PURCHASE DATE.

## **WARRANTY EXCLUSIONS:**

- Parts considered as normal maintenance such as: filtering elements, belts, hoses, nozzles, pistons, pressure gauges, as well as usual maintenance, adjustments, retightening, lubrication and painting.
- Parts which show wear or tear due to use, UNLESS THEY SHOW DEFECTS IN WORKMANSHIP, ASSEMBLY OR MATERIAL.
- Hydraulic, lubricating oils and grease.
- Injuries of personal or material nature to the user, owner, or third parties.
- Additional charges resulting from paralyzation and repair of the equipment.
- Freight charges, pick up and delivery charges.
- Damages of any nature resulting from action of gases or liquids used in the equipment.

## **GENERAL INFORMATION:**

- Defective parts replaced under warranty period shall be property of JACTO.
- Eventual delays in performing services do not confer to the owner the right to indemnity or to extension of the warranty period.
- JACTO reserves the right to change its products or to interrupt manufacturing the equipment.
- THIS LIMITED WARRANTY shall be understood by its expressed terms, and no one in anyway subject to JACTO shall be authorized to modify or amplify the conditions prescribed herein.
- In case of need for warranty request, call for the authorized dealer supplying all information required for a prompt compliance. Do not forget the identification of the equipment, total hours of work, and the noticed defect.

FOR THIS WARRANTY TO BECOME EFFECTIVE THE PRODUCT REGISTRATION CARD FOUND IN THE INSTRUCTION MANUAL MUST BE FILLED IN AND RETURNED TO YOUR JACTO DEALER. THIS CARD MUST BE SIGNED BY THE ORIGINAL RETAIL PURCHASER, INDICATING THAT HE HAS READ AND UNDERSTOOD ALL SAFETY AND OPERATIONAL INSTRUCTIONS IN THE MANUAL. FURTHER THE RETAILING DEALER HAS EXPLAINED TO THE ORIGINAL RETAIL PURCHASER ALL SAFETY INSTRUCTIONS. IN NO CASE WILL WARRANTY BE SUPPLIED UNTIL THIS CARD, PROPERLY COMPLETED AND SIGNED, IS ON FILE WITH JACTO RETAILING DEALER.



# PRODUCT REGISTRATION CARD

INVOICE NUMBER: \_\_\_\_\_ DATE: \_\_\_\_ / \_\_\_\_ / \_\_\_\_

RETAILING DEALER: \_\_\_\_\_

PHONE: \_\_\_\_\_ CITY: \_\_\_\_\_ STATE: \_\_\_\_\_

SPRAYER: \_\_\_\_\_ MODEL: \_\_\_\_\_

SERIES: \_\_\_\_\_ SPRAYER No.: \_\_\_\_\_ PUMP No.: \_\_\_\_\_

ORIGINAL RETAIL PURCHASER: \_\_\_\_\_

ADDRESS: \_\_\_\_\_ PHONE: \_\_\_\_\_

CITY: \_\_\_\_\_ STATE: \_\_\_\_\_

PURCHASE DATE BY THE ORIGINAL RETAIL PURCHASER: \_\_\_\_ / \_\_\_\_ / \_\_\_\_

THE WARRANTY IS IN FORCE AS OF THIS DATE: \_\_\_\_ / \_\_\_\_ / \_\_\_\_

RETAIL PURCHASER SIGNATURE: \_\_\_\_\_

Original retail purchaser's copy



# PRODUCT REGISTRATION CARD

INVOICE NUMBER: \_\_\_\_\_ DATE: \_\_\_\_ / \_\_\_\_ / \_\_\_\_

RETAILING DEALER: \_\_\_\_\_

PHONE: \_\_\_\_\_ CITY: \_\_\_\_\_ STATE: \_\_\_\_\_

SPRAYER: \_\_\_\_\_ MODEL: \_\_\_\_\_

SERIES: \_\_\_\_\_ SPRAYER No.: \_\_\_\_\_ PUMP No.: \_\_\_\_\_

ORIGINAL RETAIL PURCHASER: \_\_\_\_\_

ADDRESS: \_\_\_\_\_ PHONE: \_\_\_\_\_

CITY: \_\_\_\_\_ STATE: \_\_\_\_\_

PURCHASE DATE BY THE ORIGINAL RETAIL PURCHASER: \_\_\_\_ / \_\_\_\_ / \_\_\_\_

THE WARRANTY IS IN FORCE AS OF THIS DATE: \_\_\_\_ / \_\_\_\_ / \_\_\_\_

RETAIL PURCHASER SIGNATURE: \_\_\_\_\_

**URGENT  
RESPOND WITHIN 30 DAYS  
FIRST CLASS POSTAGE REQUIRED**