

FALCON VORTEX HORTI

English version - MI-0160

**EDITION - 04/2005
CODE - 976738**

Operator's Manual



MÁQUINAS AGRÍCOLAS JACTO S.A.

Rua Dr. Luiz Miranda, 1650
17580-000 - Pompéia - SP - Brasil

Tel.: +55 14 3405-2100

Fax: +55 14 3452-1916

E-mail: export@jacto.com.br

Home page: www.jacto.com.br

INTRODUCTION

The agrochemicals application is necessary to achieve higher and economical production.

However, as it is a work that can bring risks to the human being, environment and crops, Jacto has always been concerned with the proper use of its spraying machineries in an efficient and safe way.

Therefore, read carefully and understand thoroughly this manual before operating this sprayer and keep it always at hand when handling this sprayer for quick consult in case you are not quite sure of some operation or adjustment.

Should your doubt persist, please contact your Jacto dealer.

MÁQUINAS AGRÍCOLAS JACTO S.A.
CONTRIBUTING TO THE AGRICULTURE DEVELOPMENT.

IDENTIFICATION PLATE

Your sprayer has a plate showing its model and serial number.

This information is very important so that Jacto can keep records of eventual modifications made on the material used and on its construction characteristics.

In requesting replacement parts or maintenance, always specify the model and serial number of your sprayer for prompt and efficient service.

	jacto	MACHINE NO.
MACHINE:		
MODEL:		
SERIES:	WEIGHT	kg
<small>MAQUINAS AGRÍCOLAS JACTO S.A. - CNPJ 55.064.562/0001-90 RUA DR. LUIZ MIRANDA Nº 1650 - CEP 17580-000 POMPEIA-SP WWW.JACTO.COM.BR MADE IN BRAZIL</small>		

JACTO and **FALCON** are trademarks registered by Máquinas Agrícolas Jacto S.A.

**JACTO RESERVES THE RIGHT TO CHANGE SPECIFICATIONS AND DESIGN
WITHOUT PRIOR NOTICE.**

ÍNDICE

Safety Precautions	
Handling agricultural sprayers	05
Handling chemical products	06
Decals	07
Safety measures	09
Technical Specifications	
FALCON VORTEX (with 35 cm nozzle spacing)	10
FALCON VORTEX (with 50 cm nozzle spacing)	11
Main components of sprayer	
Suction filter	13
Chemical pump	13
Pressure regulators	14
Hydraulic boom control	15
Movement sensor	18
Nozzles	18
Clean water tank (for washing hands)	19
PTO shaft	19
Boom joint	19
In-line filter	19
Low pressure gauge kit	20
Foam marker (OPTIONAL)	20
Chemicals mixer	22
Mixing chemicals	22
Chemical container rinse nozzle	23
Flow bypass valve	24
Hydraulic agitator	24
Filler unit (OPTIONAL)	25
Fan rotation adjusting valve	26
Spray boom	26
Operational procedures	27
Setting up the tractor	28
Connecting the PTO	30
Assembling the electro-electronic control	31
Assembling the boom	32
Boom unfolding and folding	38
Operation and adjustments	
Spray application technology	40
Pressure regulator	41
Nozzles	43
Calibrating the sprayer	47
Diluting the chemicals	49
Maintenance	
Guidelines	50
Components	50
Lubrication table	53
Lubrication points	53
PTO shaft	56
Winter storage	57
Trouble-shooting	58
General care	
Handling agricultural sprayers and chemicals	61
After spraying	61
Warranty Statement	62

SAFETY INSTRUCTIONS

HANDLING AGRICULTURAL SPRAYERS

OWNER / OPERATOR:

This sprayer was carefully designed and built so as to give you the maximum production, saving, easy operation and safety.

Therefore, you or anyone else who is going to operate, maintain and work around this sprayer must read and understand this manual thoroughly in order to be familiar with all the operating and maintenance procedures and safety information related to this sprayer. All accidents can be prevented if all the safety instructions are correctly followed.

Moreover, always keep this manual at hand for quick review in case of doubt.



ATTENTION
FAILURE TO FOLLOW THE SAFETY INSTRUCTIONS PROPERLY WILL RISK YOUR OWN LIFE AS WELL AS THE LIFE OF PEOPLE WORKING AND LIVING AROUND YOU.

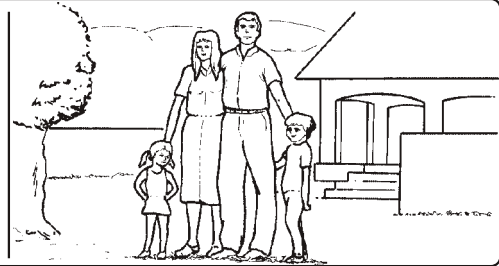

This safety alert symbol identifies important safety messages. When you see it, be alert to any possibility of personal injury or death. Keep all the decals on the sprayer and replace them if missing or illegible.

- Before operating this sprayer, read carefully and understand thoroughly this manual.
- Do not allow untrained people to operate this sprayer because this can cause serious injuries or fatal accidents.
- Do not modify this sprayer in any way because this can impair the function and risk your safety.
- Keep away children, aged people and animals while operating, servicing this sprayer and even when the sprayer is stored.
- In the delivery of your sprayer, have your Jacto dealer instruct you on the assembly, operation, maintenance and warranty in detail.
- Keep hands, feet and clothing away from moving parts.
- Never use loose clothing or mittens while working around the sprayer.
- Do not travel at high speeds.
- **Always stop tractor engine, disengage the PTO and wait for all moving parts to stop before servicing, adjusting or repairing the sprayer.**

ATTENTION: Do not touch PTO shafts, belts, fans or any other moving part while the sprayer is running.

- Only unhitch the sprayer on firm and level ground.
- Keep your sprayer in thorough repair.

SAFETY INSTRUCTIONS

HANDLING CHEMICALS

Chemical products are classified in four categories of toxicity. According to their toxicity level, there is a special recommendation of appropriate protective equipment.

As your safety concerns first, we list below all the protective equipment recommended for handling chemical products of the category 1 which includes high toxicity level chemicals.

This way, all the possibilities of serious illness and death are eliminated.

Obligatory individual protective equipment for handling and spraying chemicals:

- Long-sleeved working clothes
- Impermeable apron or coverall
- Impermeable gloves
- Impermeable wide-brimmed hat
- Boots
- Special protective masks equipped with appropriate filters for each type of product

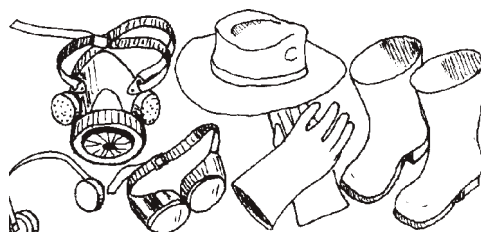

CHEMICAL PRODUCTS CLASSIFICATION

	TOXICITY LEVEL		LABEL COLOR ON CHEMICALS CONTAINER
	I	HIGH	RED
	II	MODERATE	YELLOW
	III	LOW	BLUE
	IV	LIGHT	GREEN

DIRECTIONS

- Read and follow all instructions on the chemicals manufacturer's label.
- Keep the chemical products closed and in a dry and ventilated place.
- Use the chemical products in agriculture only.
- Keep away children, untrained people and animals.
- Handle the chemicals following recommendations of a technician.
- Always handle chemicals in a ventilated place and equipped with individual protective equipment.
- Use the application rate as per instructions on the labels.
- Do not make spray applications in the wind or hot weather.
- Do not drink, eat or smoke while spraying or handling chemicals.
- Keep children, untrained people and animals away from the application areas.
- Never blow through nozzles strainers, valves or pipelines by mouth.
- Do not store or transport chemical products together with food, medicines, people, animals.
- Make sure rivers, lakes, etc. will not be contaminated when washing out the sprayer.
- After spraying, take off all protective clothing and take a shower.
- In case of intoxication, go see a doctor immediately and show him the chemical products label.
- Never medicine an unconscious person through mouth.
- **Do not re-use the chemical products containers for other purposes. Consult an agronomist on how to discard empty containers of chemical products.**

SAFETY INSTRUCTIONS

DECALS

Safety decals are placed on the equipment to reduce the risk of damages or accidents to the operator or to the equipment during the use.

Before operating the equipment, identify and understand the mean of all decals, through this page.

Keep them in good repair, clean and legible. Replade them immediately in case of damage by ordering them through the part numbers specified below.



ATTENTION: Lubrication point

P/N: 276220



ATTENTION: Drain point.

P/N: 389387



ATTENTION: Lubrication point with oil.

P/N: 395061



ATTENTION: Clean water tank to wash the hands.

P/N: 379073



ATTENTION: Read the operator's manual before operating the sprayer.

P/N: 379248



ATTENTION: Hydraulic oil level indicator.

P/N: 379107



ATTENTION: Obligatory use of protective clothing.

P/N: 379131



ATTENTION: Obligatory use of hearing protector.

P/N: 379123



ATTENTION: Read the operator's manual before operating the sprayer.

P/N: 379230

SAFETY INSTRUCTIONS



ATTENTION: Risk of serious injuries. Do not make any operation on the PTO shaft if the PTO is engaged.

P/N: 379008



ATTENTION: Risk of serious injuries. Do not maneuver the sprayer close to electricity supply cables.

P/N: 378992



ATTENTION: Risk of serious injuries. Keep all protection devices in its places.

P/N: 379065



ATTENTION: Obligatory use of protective mask.

P/N: 379115



ATTENTION: Risk of injuries. Keep away from the sprayer when it is running.

P/N: 379040



ATTENTION: Maximum speed allowed for the machine is 30 km/h.

P/N: 379214



ATTENTION: Risk of serious injuries. Keep away and do not make any kind of maintenance while the fan is in motion and the PTO is engaged.

P/N: 379057



ATTENTION: This machine is not allowed in highways.

P/N: 379222

	Nº DA MÁQUINA
MÁQUINA:	
MODELO:	
SÉRIE:	PESO: kg
MÁQUINAS AGRÍCOLAS JACTO S.A. - CNPJ 05.064.952/0001-99 RUA DR. LUÍZ ARRANCHA Nº 1559 - CEP 17030-400 FOMPSA-SP WWW.JACTO.COM.BR MADE IN BRAZIL	

Identification plate

P/N: 997841



Final test of the equipment.

P/N: 013169

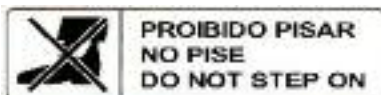

Decal do not step on
P/N: 958629

SAFETY INSTRUCTIONS



ATTENTION: THIS SAFETY ALERT SYMBOL IDENTIFIES IMPORTANT SAFETY MESSAGES. WHEN YOU SEE IT, BE ALERT TO ANY POSSIBILITY OF PERSONAL INJURY OR DEATH.

SAFETY MEASURES

- Keep all the protectors on their proper places.
- Remove the controls installed on the tractor before disconnecting the sprayer.
- Do not operate the pump without liquid.
- Clean and lubricate regularly the male and female parts of the PTO shaft to reduce the friction between them.
- Lubricate daily the grooved shaft of the tractor's PTO.
- Keep the hands, feet and clothes away from PTO shafts and any type of transmission, once they can cause serious injuries, even death.
- Never operate the sprayer if the PTO shaft, the sprayer and the tractor's PTO protectors are not in their proper place.
- Do not exceed 580 rpm at the PTO.
- The PTO shaft protector must always remain in good repair and fastened by the belts. The PTO shaft must work freely in its interior.
- The PTO shaft coupling ends must be locked on the tractor's PTO and sprayer's shaft.
- Make sure the drawbar and the sprayer end are properly engaged.
- Follow these recommendations strictly in order to avoid injuries or death.
- Check and change the worn and broken parts. Check if all protectors are in their places before operating the sprayer.
- Make sure that no one is close to the machine before running the engine.
- Stop the engine before leaving the operator's position to adjust, clean or lubricate, save other recommendation indicated on the operator's manual.
- Stop the machine and all moving parts before adjusting, maintenance or when there are people close to the equipment.
- Do not go up on the sprayer when it is in motion.

ELECTRICITY SUPPLY CABLES

- Attention when passing next or under an electricity supply cables. In case of doubt, change the course.
- Never fold and unfold the booms close to the electricity supply cables.
- The sprayer must be trailed by the tractor in the farm with the spray booms folded and locked. Always place the sliding frame at the lowest position (rest position of the fixed frame).
- Remove the booms of the sprayer before transporting it by wagons, trucks or trailers.

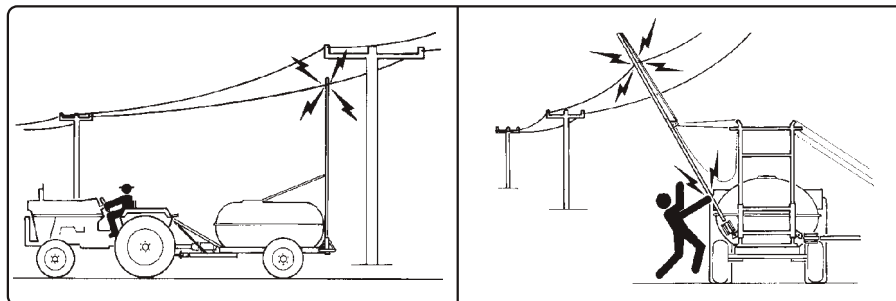

TECHNICAL SPECIFICATIONS

FALCON VORTEX (with 35 cm nozzle spacing)

TECHNICAL SPECIFICATIONS	
Length (mm)	1,670
Width (mm)	2,450
Height (mm)	2,820 (without boom) 3290 (with folded boom)
Weight (kg)	730 (with full oil tank)
Tank	
- Capacity (liters)	600
- Material	Polyethylene
Filter	
- Model	FVS-100
- Mesh	60
Pump	
- Model	JP-75
- Capacity (L/min)	75
- Maximum working pressure (kgf/cm ² - psi)	28 - 400
.....	NOTE: Maximum allowed on this sprayer: 150 psi (10.5 kgf/cm ²)
- Power consumption (HP)	2.3 with the pump at 150 psi
Pressure gauge	
- Model	With extended scale
Control	
- Model	Masterflow
Nozzles	
- Type	Bijet double nozzle holder
- Quantity	82
- Model	JA-2 (cone) / AXI 110-02 (flat fan)
- Recommended maximum pressure (kgf/cm ² - psi)	JA-2 (10.5 - 150) / AXI-02 (4.2 - 60)
- Spacing (cm)	35
Boom	
- Length (m)	14.0
- Actuation	Hydraulic
- Height (m)	0.50 a 1.30
Level indicator	Hose attached to the tank
Agitation	Hydraulic system with venturi
Filler unir (OPTIONAL)	
- Model	EJ-250
Fan	
- Rotation (rpm)	2,800
- Air volume (m ³ /min)	533 (32,000 m ³ /h)
- Air speed (km/h)	100 (w/ boom at the lowest position)
- Power consumption (HP)	21.3
Hydraulic pump	
- Capacity (L/min)	50
- Rotation (rpm)	2,250
- Oil type	ISO VG-68
- Oil reservoir capacity (liters)	45
Maximum power consumption (HP)	23.6
RECOMMENDED TRACTOR	80 HP
Recommended maximum working speed (km/h)	10

TECHNICAL SPECIFICATIONS

FALCON VORTEX (with 50 cm nozzle spacing)

TECHNICAL SPECIFICATIONS	
Length (mm)	1,670
Width (mm)	2,450
Height (mm)	2,820 (without the boom) 3,290 (with folded boom)
Weight (kg)	730 (with full oil tank)
Tank	
- Capacity (liters)	600
- Material	Polyethylene
Filter	
- Model	FVS-100
- Mesh	60
Pump	
- Model	JP-75
- Capacity (L/min)	75
- Maximum working pressure (kgf/cm ² - psi)	28 - 400 NOTE: maximum allowed on this sprayer: 150 psi (10.5 kgf/cm ²)
- Power consumption (HP)	2.3 with the pump at 150 psi
Pressure gauge	
- Model	with extended scale
Control	
- Model	Masterflow
Nozzles	
- Type	Bijet double nozzle holder
- Quantity	58
- Model	JA-2 (cone) / AXI 110-02 (flat fan)
- Recommended maximum pressure (kgf/cm ² - psi)	JA-2 (10.5 - 150) / AXI-02 (4.2 - 60)
- Spacing (cm)	50
Boom	
- Length (m)	14.0
- Actuation	Hydraulic
- Height (m)	0.50 to 1.30
Level indicator	Hose attached to the tank
Agitator	Hydraulic system with venturi
Filler unit (OPTIONAL)	
- Model	EJ-250
Fan	
- Rotation (rpm)	2,800
- Air volume (m ³ /min)	533 (32,000 m ³ /h)
- Air speed (km/h)	100 (w/ boom at the lowest position)
- Power consumption (HP)	21.3
Hydraulic pump	
- Capacity (L/min)	50
- Rotation (rpm)	2,250
- Oil type	ISO VG-68
- Oil reservoir capacity (liters)	45
Maximum power consumption (HP)	23.6
RECOMMENDED TRACTOR	80 HP
Recommended maximum working pressure (km/h)	10

TECHNICAL SPECIFICATIONS

AVAILABLE VERSIONS OF FALCON VORTEX

DESCRIPTION	CONTROLS					
	MASTERFLOW			V.A.R		
	2 WAYS	4 WAYS	(Electro electrónico with JEC 3600 and JSC 5000)	(Electric JEC 3900)	2 WAYS	4 WAYS
Nozzle holder	BIJET	BIJET	BIJET	BIJET	BIJET	BIJET
Nozzles						
- Model (FALCON VORTEX)	JA-2 / AXI-100.02	JA-2 / AXI-100.02	JA-2 / AXI-100.02	JA-2 / AXI-100.02	JA-2 / AXI-100.02	JA-2 / AXI-100.02
- Spacing	0,50	0,50	0,50	0,50	0,50	0,50
- Quantity	29	29	29	29	29	29
- Spacing	0,35	0,35	0,35	0,35	0,35	0,35
- Quantity	41	41	41	41	41	41
Spray pump						
- Model	JP-75	JP-75	JP-75	JP-75	JP-75	JP-75
- Capacity	75 L/min	75 L/min	75 L/min	75 L/min	75 L/min	75 L/min

FALCON VORTEX - OPTIONS		
FILLER UNIT	MODEL	FONTELIMPA WITH QUICK FITTING
PUMP	MODEL	JP-100

MAIN COMPONENTS OF SPRAYER

SUCTION FILTER

Located between the tank and pump, the suction filter is specifically designed to prevent dirt or impurities from reaching the pump.

It has an easy-to-reach shut off valve which stops the liquid flow to allow filter cleaning, filtering elements changing and/or pump maintenance.

This shut off valve must remain open while the sprayer is running. If it remains closed, you will hear an unusual noise in the pump.

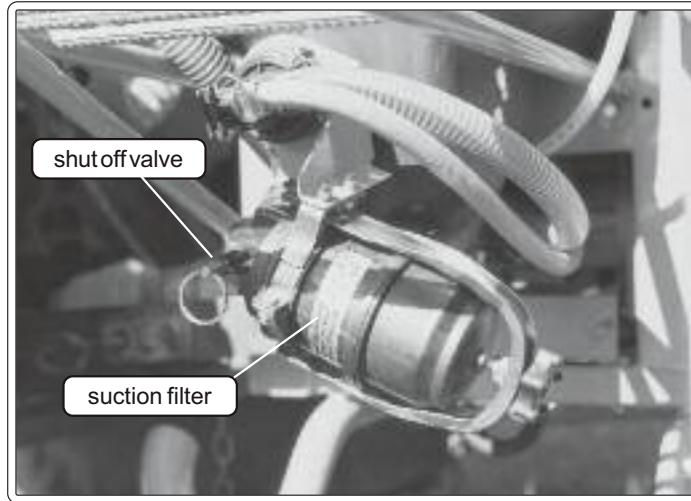

SPRAY PUMP

The spray pumps used in the FALCON VORTEX sprayers have capacity ranging from 75 to 100 liters per minute.

SPRAY PUMP MODEL	FLOW RATE (L/min)	MAXIMUM WORKING PRESSURE	
		psi	kgf/cm ²
JP - 75	75	300	21
JP - 100	100	300	21

- Its ceramic sleeves ensure great resistance to abrasion and chemical action.

Piston cup replacement becomes easier by removing the head assembly in a quick and simple operation, with no need to remove the pump.

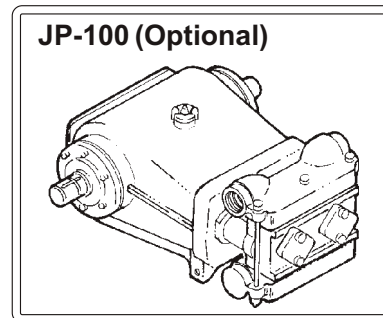
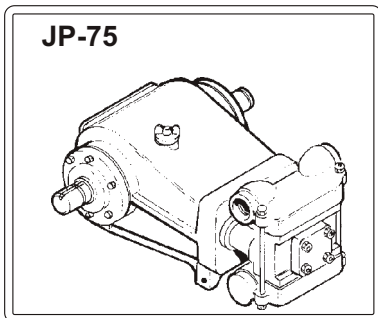

NOTE: Due to the characteristics of the chemical control, the maximum attained in the pressure line on the **FALCON VORTEX** 10.5 kgf/cm² (150 psi).

MAIN COMPONENTS OF SPRAYER

PRESSURE REGULATOR

MASTERFLOW CONTROL

This pressure regulator control provides great sensitivity and accuracy in the calibrations.

Besides, it has two basic functional characteristics in comparison with the conventional controls.

- FLOW PROPORTIONAL TO TRAVEL

The application rate remains unchanged per sprayed area even if the engine rotation fluctuates within a same gear.

- CONSTANT WORKING PRESSURE ALONG THE WHOLE BOOM, REGARDLES OF THE NUMBER OF BOOM SECTIONS TURNED ON

This control has a system that enables to calibrate the return of each boom section, thus maintaining the same pressure in all sections, independent of the number of sections turned on or off.

ATTENTION

To ensure longer life of the pressure gauge, close the lever (1) after calibrating the sprayer, thus releasing the pressure, and close the pressure gauge valve.

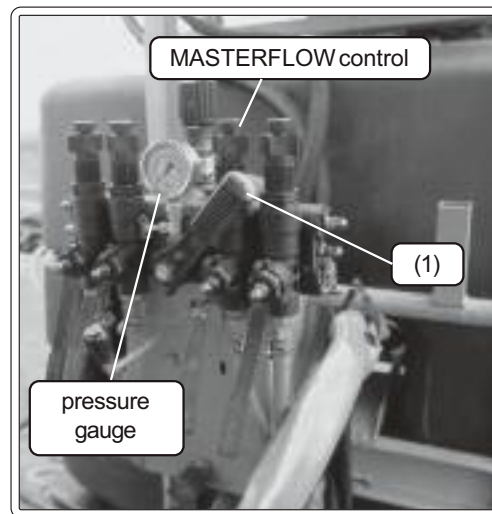

CONTROL V.A.R.

- This pressure regulator provides calibration ranging from 2 to 35 kg/cm² (30 to 500 psi), indicated by the pressure gauge.

The levers (1) and (2) have different jobs. The lever (1) turns on and off the chemical flow while the lever (2) distributes the chemical flow to the right and left nozzles branches or the one only. This makes applications easier and with less wastage of agrochemicals.

ATTENTION: In order to insure longer life of the pressure gauge, close lever (1) after regulating the sprayer, thus releasing the pressure, and close the pressure gauge valve.

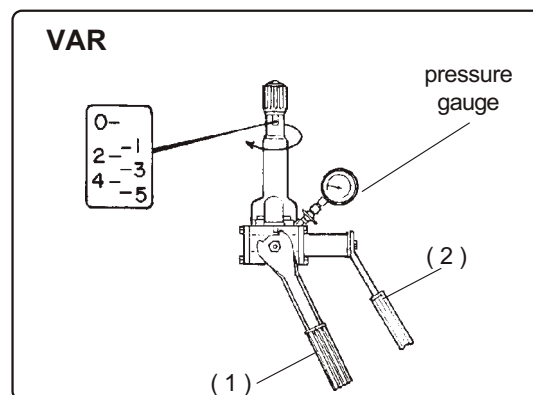

MAIN COMPONENTS OF SPRAYER

HYDRAULIC BOOM CONTROLS

BASIC CONTROL

This control is mounted to the tractor fender on the most convenient position to the operator.

It comprise 3 levers:

- Lever 01: raises and lower the right boom.
- Lever 02: raises and lower the frame.
- Lever 03: raises and lower the left boom.

The boom can also be unfolded and folded through the hydraulic control.

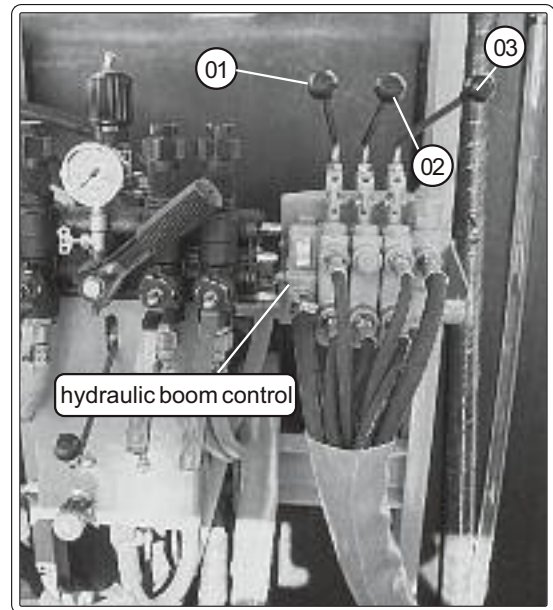

JEC-3900 ELECTRIC CONTROL

Located under the spray control, the electric hydraulic boom control is connected to the distributing box, which is connected to the control panel fastened near to the operator.

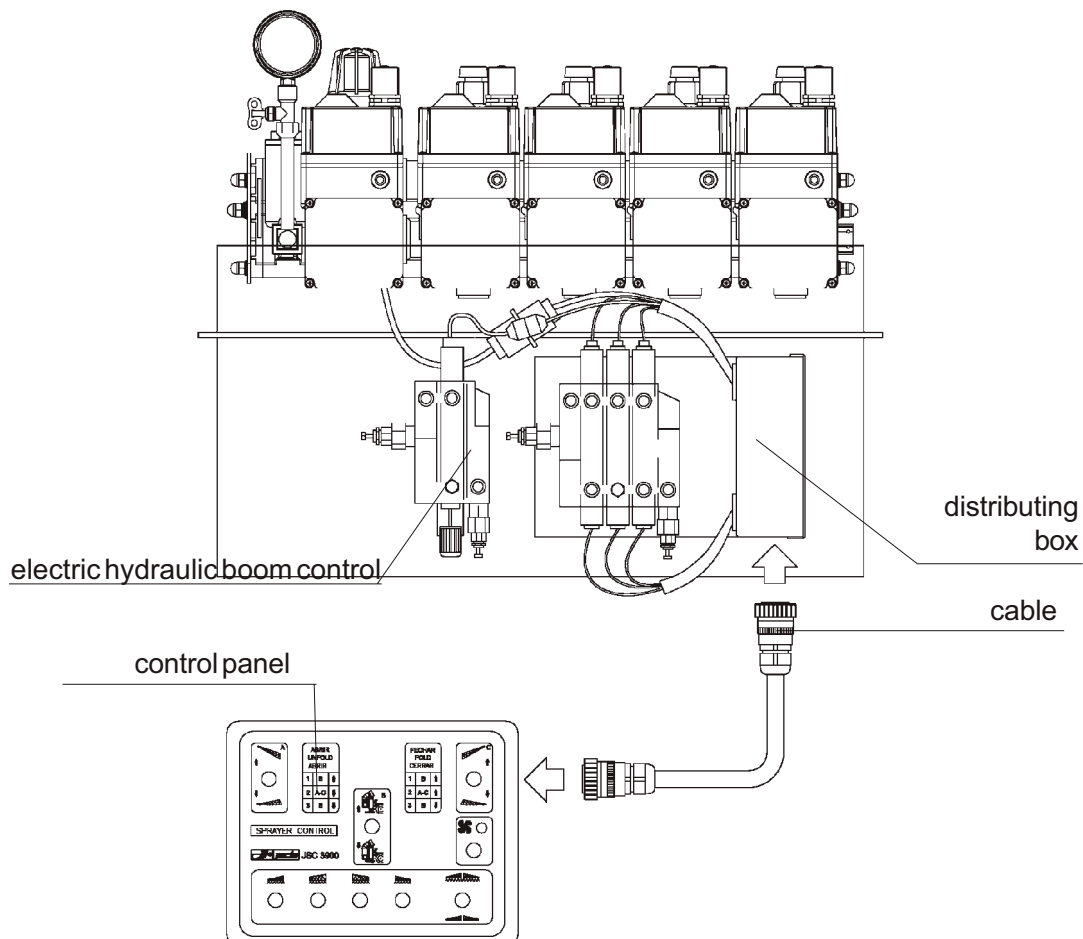

MAIN COMPONENTS OF SPRAYER

CONTROL PANEL

ELECTRIC HYDRAULIC BOOM CONTROL and SPRAYER CONTROL

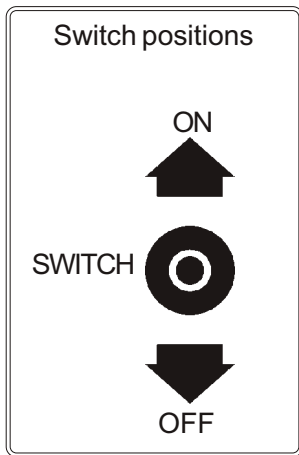
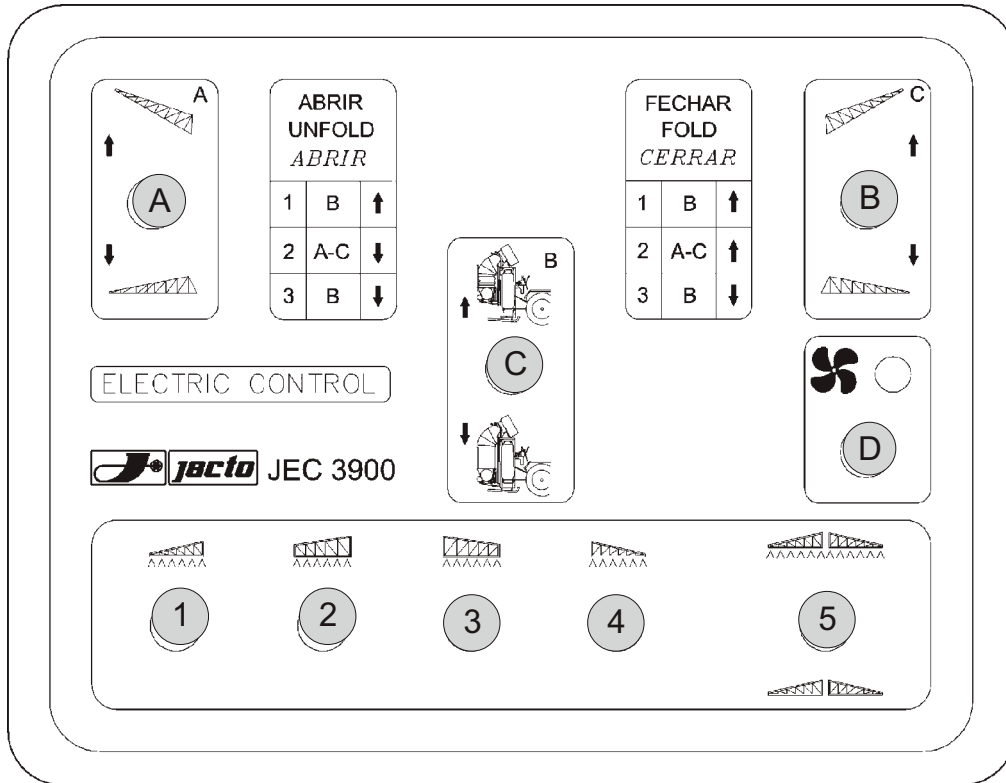

Switch A: raises and lower the right boom.
 Switch B: raises and lower the left boom.
 Switch C: raises and lower the frame.
 Switch D: Turn on/off the fan.

Sprayer Control

Switch 1: turns on the spray to the 2nd section of the right boom.
 Switch 2: turns on the spray to the 1st section of the right boom.
 Switch 3: turns on the spray to the 1st section of the left boom.
 Switch 4: turns on the spray to the 2nd section of the left boom.
 Switch 5: directs the flow to the booms or to the tank (return).

NOTE: To actuate the switches 1, 2, 3 or 4, the switch 5 must be on (upward).

MAIN COMPONENTS OF SPRAYER

ELECTRIC-ELECTRONIC MASTERFLOW CONTROL WITH JSC-5000 SPRAYER CONTROL AND JEC3600 ELECTRIC BOOM CONTROL

The JEC-3600 control allows to simply unfold and fold the booms.

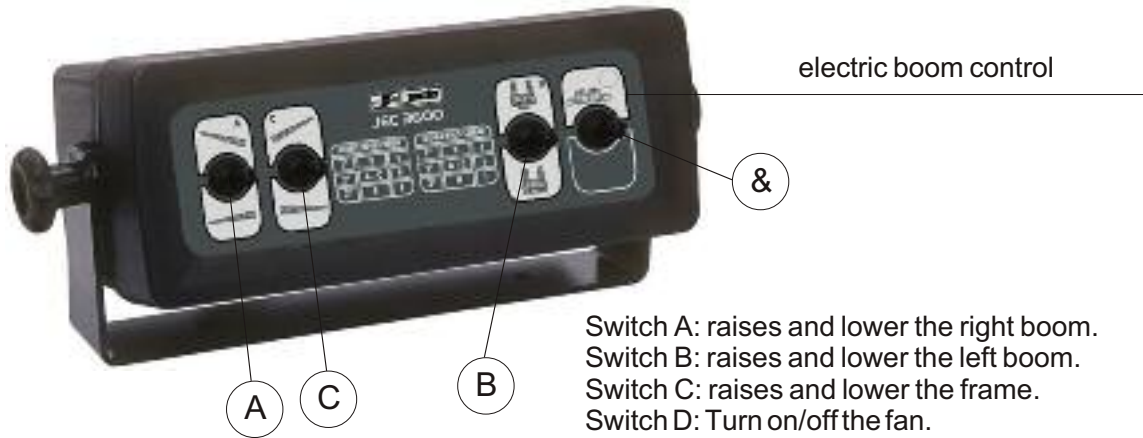

Electro-Electronic Masterflow Control

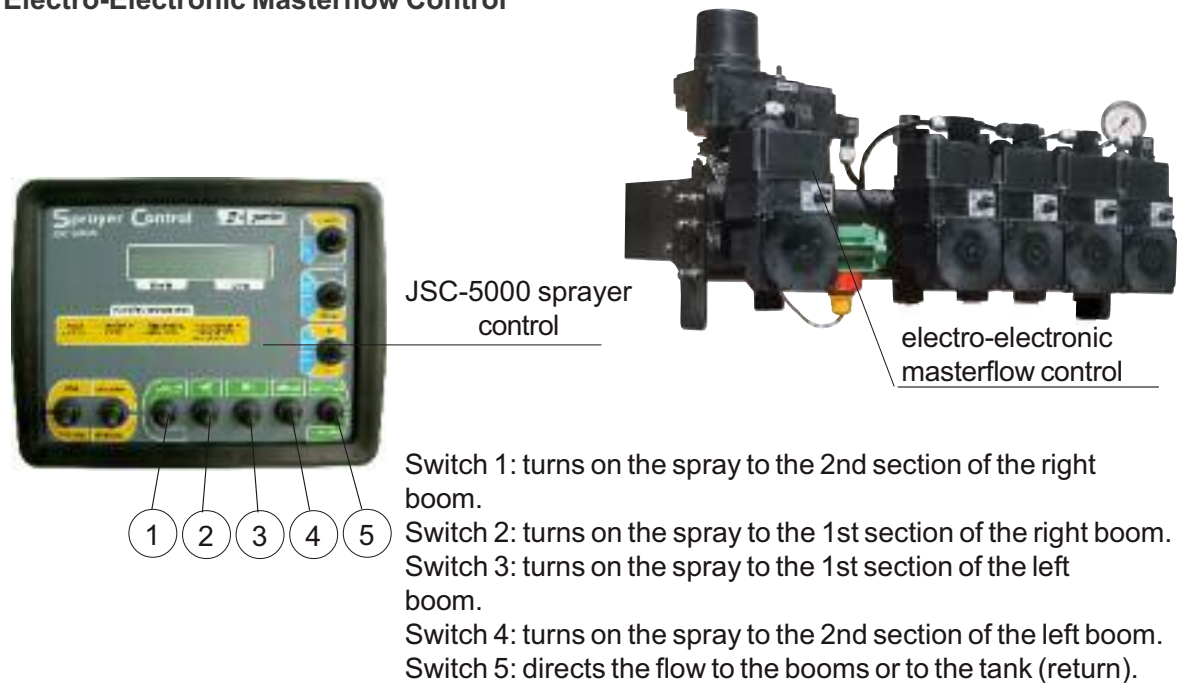

This is a system that automatically calibrates the sprayer and ensures constant liquid quantity distributed per area, regardless of the speed fluctuations within the same gear.

With the introduction of the JSC-5000, the farmer will save time and chemicals. 10% errors are practically unavoidable in manual calibrations, which are per trial and error. Besides the error in the calibrations, the tractor speed fluctuations also affect the result. The JSC-5000 compensates all fluctuations on the working speed and keeps constant liquid volume per area.

MAIN COMPONENTS OF SPRAYER

MOVEMENT SENSOR

The movement sensor is a device designed to replace the wheel sensor and its functions. It provides the JSC-5000 with pulse signals that are converted in information for better use of the equipment and chemical application.



sensor support

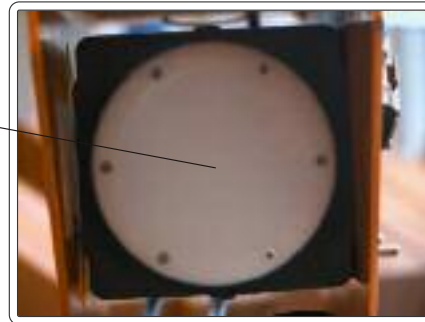

movement sensor

BIJET NONDRIP DOUBLE NOZZLE HOLDER

The Bijet nozzle holder comprises a nondrip valve and two ceramic nozzles - 1 cone and 1 flat fan.

Its nondrip valve shuts off the chemical mixture flow once the pressure comes down to 10 psi, thus preventing it from dripping.

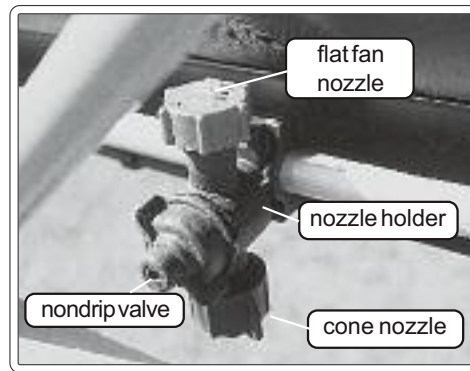

NOZZLES

The job of the nozzles is to generate droplets and distribute them uniformly over the surface being sprayed.

Flow, angle and droplet sizes vary according to working pressure. Operating with pressure over that recommended by the manufacturer will decrease the nozzles' life.

This sprayer is equipped with alumina (ceramic) nozzles, which are very resistant to wear and to chemical action, and fitted as shown in the figure below.

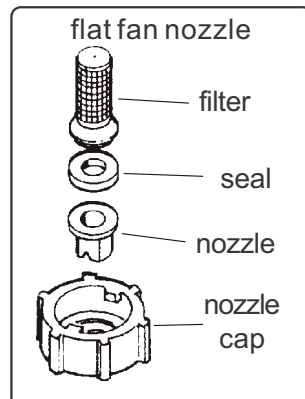
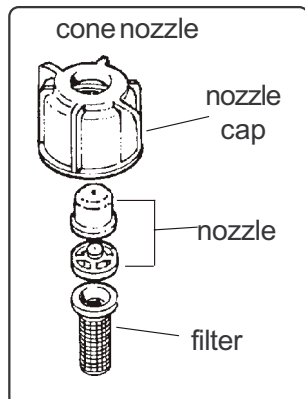

ATTENTION:
Operating at pressures above or below the recommended can alter the nozzles working characteristics.

MAIN COMPONENTS OF SPRAYER

CLEAN WATER TANK

This is a plastic container with capacity of 12 liters.

Easy to reach, it must always be filled up with clean water for washing hands and other parts of the body that may have touched chemicals while preparing the chemical mixture.

ATTENTION: USE THIS WATER **ONLY** TO WASH HANDS AND OTHER PARTS OF THE BODY THAT HAVE TOUCHED CHEMICALS. **DO NOT DRINK THIS WATER UNDER ANY CIRCUMSTANCES!**

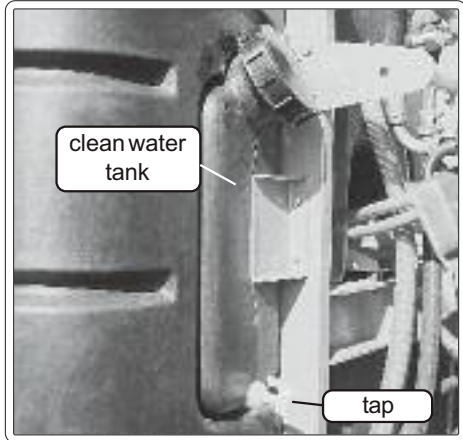

PTO SHAFT

It has plastic guards along all its parts to provide more safety to the operator. These guards prevent the rotating parts from contacting the operator and his clothes, as well as plants. Do not remove them.

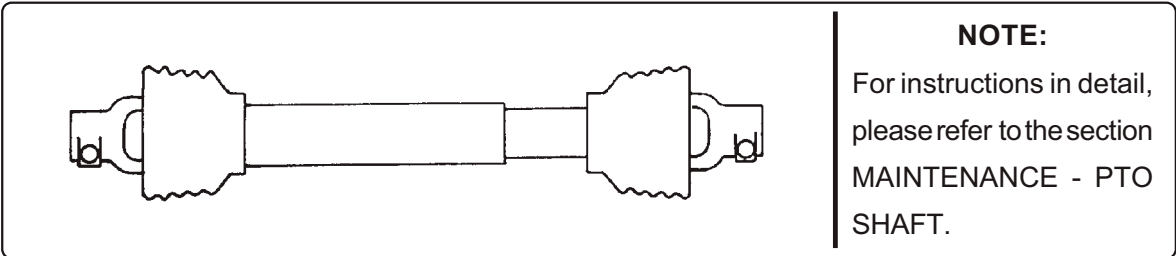

BREAKAWAY SYSTEM

This system, mounted at the boom end, is specifically designed to protect the boom against impacts.

Upon shock against obstacles, the boom end breaks away from its position, but returns to the normal operating position right after.

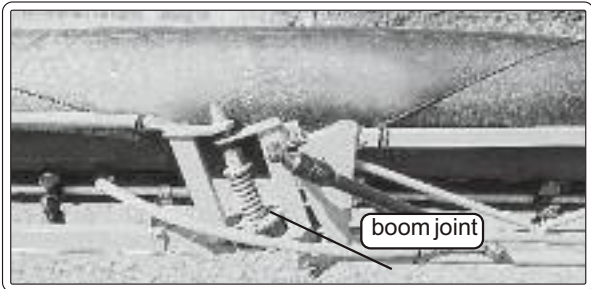

ATTENTION: This system will be able to protect the boom as long as such impacts must not be strong and frequent.

IN-LINE FILTER

NOTE: As the FALCON VORTEX HORTI operates at pressures above 150 psi, it is not equipped with this component.

It is possible to fit an in-line filter in each boom section.

This filter has 80 mesh and optimizes filtration to the nozzles.

TECHNICAL SPECIFICATIONS

Maximum working pressure	150 psi
Filtering element mesh	80
Hose fitting	ø 1/2"



MAIN COMPONENTS OF SPRAYER

LOW PRESSURE GAUGE KIT (OPTIONAL)

The low pressure gauge kit was designed for checking the actual pressure on nozzles.

It can be installed on the sprayers assembled with both universal nozzle caps and fittings and complex nozzle holders, such as double and quadruple units.

The maximum pressure of this kit is 100 psi. However, the pressure regulators of sprayers can easily reach above 100 psi, which can damage the pressure gauge. To ensure longer life of the pressure gauge, close the valve after regulating the sprayer.

LOW PRESSURE GAUGE KIT

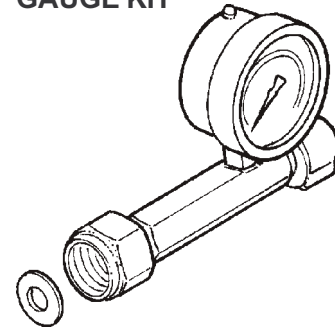

FOAM MARKER (OPTIONAL)

ASSEMBLY PROCEDURES

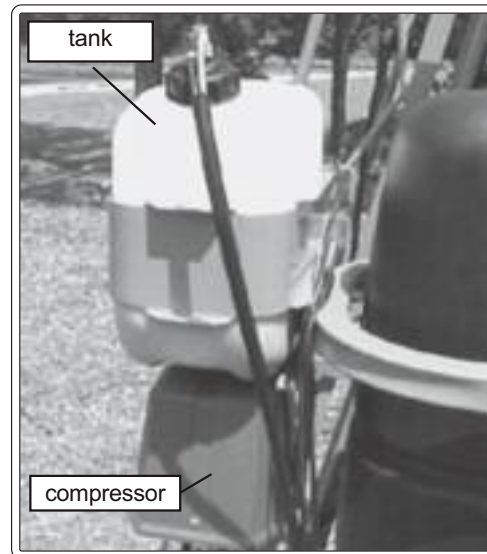
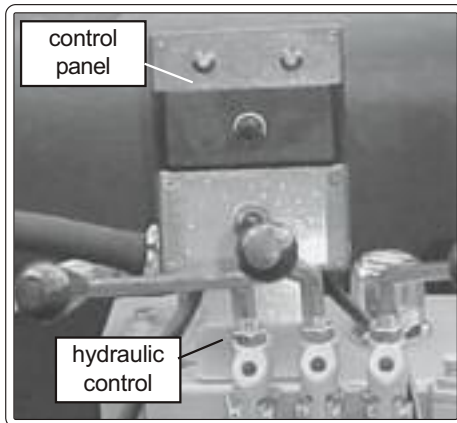

MOUNTING THE FOAM MARKER SUPPORT

- The photographs below show how to mount the foam marker support to the sprayer chassis.



MAIN COMPONENTS OF SPRAYER

MOUNTING THE FOAM NOZZLE

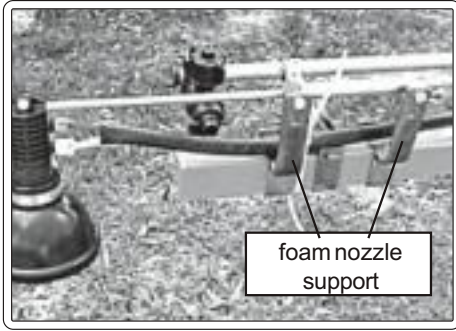

MOUNTING THE CONTROL PANEL

- The control panel must be mounted on the hydraulic control support, as shown in the photograph below.

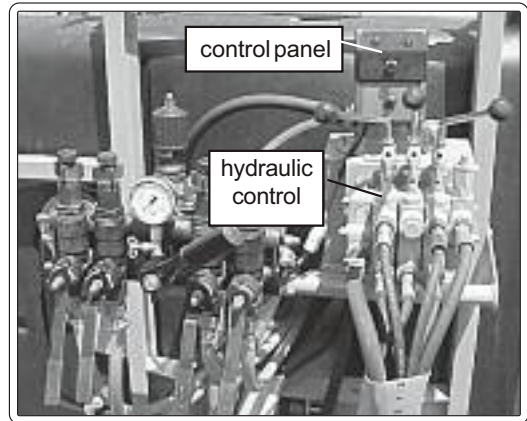
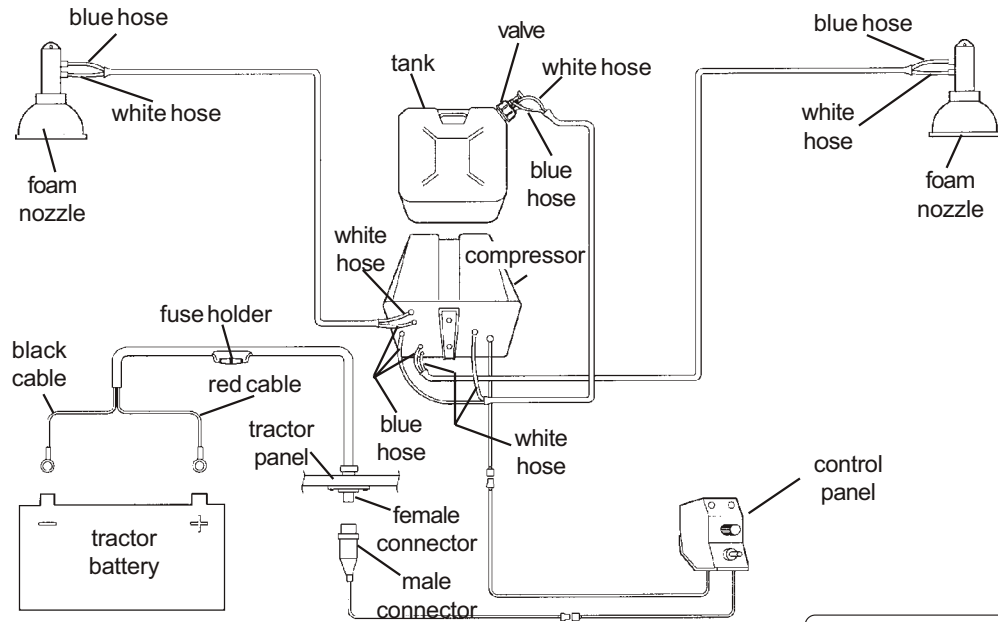

DIAGRAM OF WIRING, AIR HOSE AND FOAMING AGENT HOSE



ATTENTION:

After connecting the cables and hoses to the compressor base, tie them up as shown in the photograph besides.



NOTE: For more information on the use and maintenance of the foam marker, consult the attached specific manual.

MAIN COMPONENTS OF SPRAYER

MOUNTING THE CHEMICALS MIXER GUARD RAIL

The chemicals mixer guard rail is shipped in the accessories box. It must be secured as shown below.

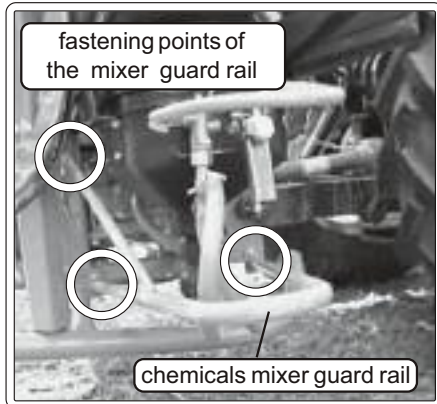

ATTENTION: Do not use the chemicals mixer guard rail as a platform to have access to the tank filler opening or to the foam marker, as this can damage the parts, as well as cause the sprayer to turn over.



CHEMICALS MIXER

This component has a 15-liter tank.

It is designed to avoid chemicals wastage, provide fast filling operation and protect the operator.

It can be used with liquids or wettable powders.

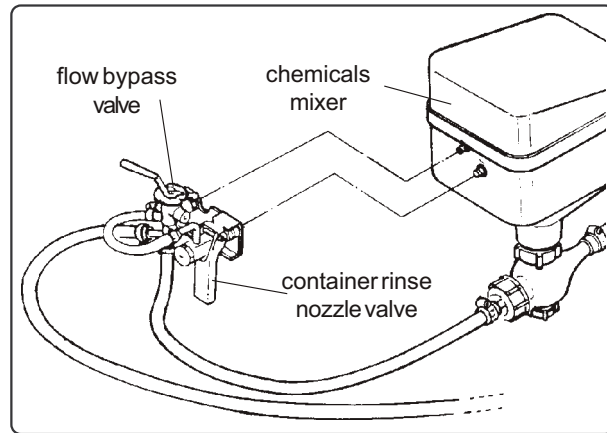

MIXING CHEMICALS

- Turn the lever (1) down (on the sprayer column the decal indicates "Incorporador" ("Chemicals Mixer")).

- Pour the chemical or solution already prepared into the mixer tank.

- Engage the PTO.

- NOTE: The lever (2) can be positioned in two settings.

1- To mix chemicals.

2- To wash inside the mixer or to rinse the chemical container.

- With the lever (2) on the position "Incorporação de defensivo" ("Mixing Chemicals"), all the chemical will be transferred to the sprayer tank.

- Rinse the chemical container; afterwards, wash inside the mixer.

- After mixing the chemical, set the lever (1) in the position "Válvulas Superiores" ("upper valves").

NOTE:

In case of liquids or wettable powders, dilute the chemical in a pre-mixture before filling the sprayer tank.

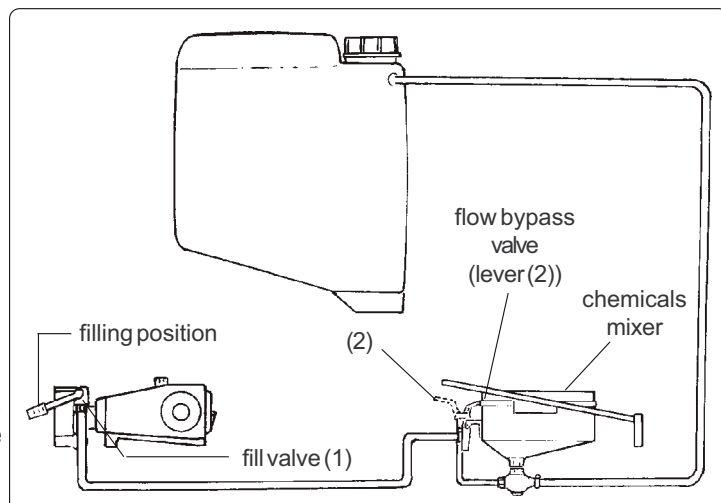

MAIN COMPONENTS OF SPRAYER

CHEMICAL CONTAINER RINSE NOZZLE

The chemical container rinse nozzle is mounted to chemicals mixer and is specifically designed to remove all chemicals residues from the container after preparing the chemical mixture for a secure disposal of such containers.

Some publications show that somewhere around 0.3% of the chemicals remains on the container after being used. Therefore, discarding the containers without washing out the residues is extremely dangerous to mankind, animals and environment.

Rinse the chemical containers right after using them, before the residues dry.

USE

- Set the lever (1) in the position "Incorporador" ("Chemicals Mixer") (detail of the decal affixed to the sprayer column).
- The lever (2) must be set in the position for washing inside the mixer.
- Hold the chemical container over the rinse nozzle.
- Engage the PTO.
- Set the lever (3) in the position to rinse the container. Simultaneously, move the container in such a way to rinse it completely.
- Repeat this operation several times.
- After rinsing the chemical container, set the lever (1) back to the position "Válvulas Superiores" ("Upper Valves").

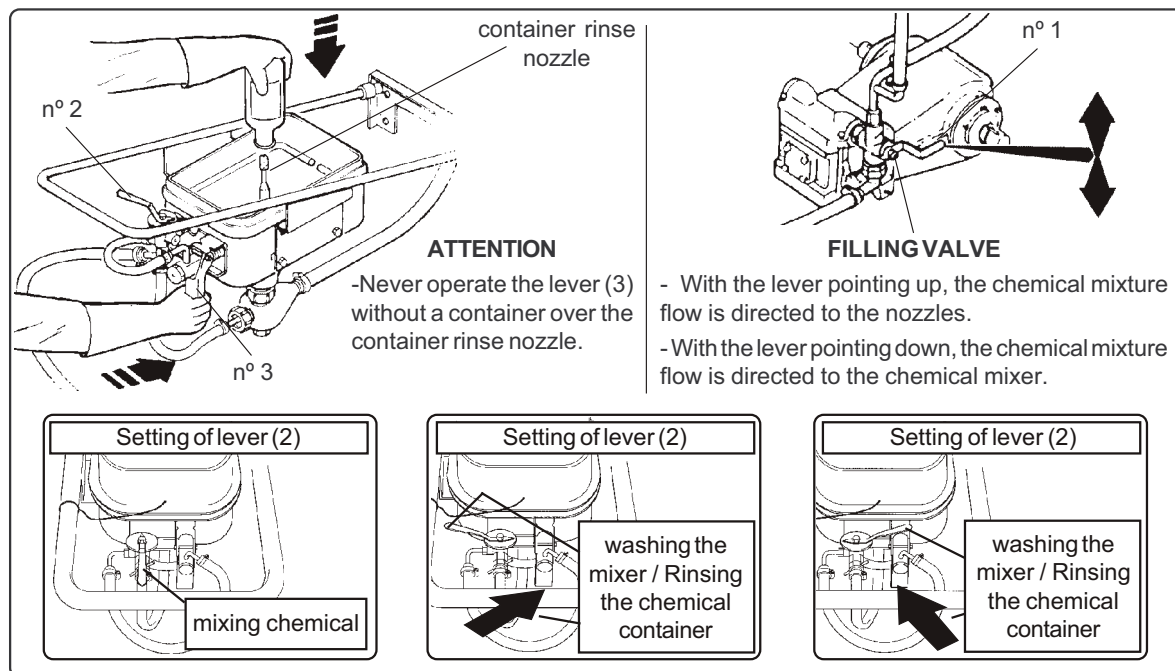

ATTENTION

- Each container should be rinsed at least twice to ensure the residues are completely removed.
- Watch out for sprinkling while rinsing the containers.
- After rinsing properly the empty chemical containers, dispose of them in an appropriate place.
- Never leave empty chemicals containers anywhere, that is, in places where any untrained person has access to.
- Prepare an appropriate place for storing empty chemicals containers where only trained person has access to until having determined the final destination for them.
- Do not reuse the chemicals containers for any other purpose, whatever it may be.
- Always follow the technical recommendations and use the appropriate individual protective clothing when handling chemicals.

MAIN COMPONENTS OF SPRAYER

FLOW BYPASS VALVE

- It bypasses the chemical mixture flow to the nozzles or to the hydraulic agitator.
- After filling the tank and mixing the chemical, engage the PTO on the way from the filling spot to the area to be sprayed.
- Set the lever of the flow bypass valve to the position "Descarga para o Tanque (agitação)" ("Discharge to the Tank (agitation)"). In this position, all the mixture will be agitated in the sprayer.
- In starting to spray, set this lever to the position "Comando de Pulverização" (" Spray Control"), in which the main flow will be directed to the spray boom. The excess on the nozzles will return normally through the circuit.

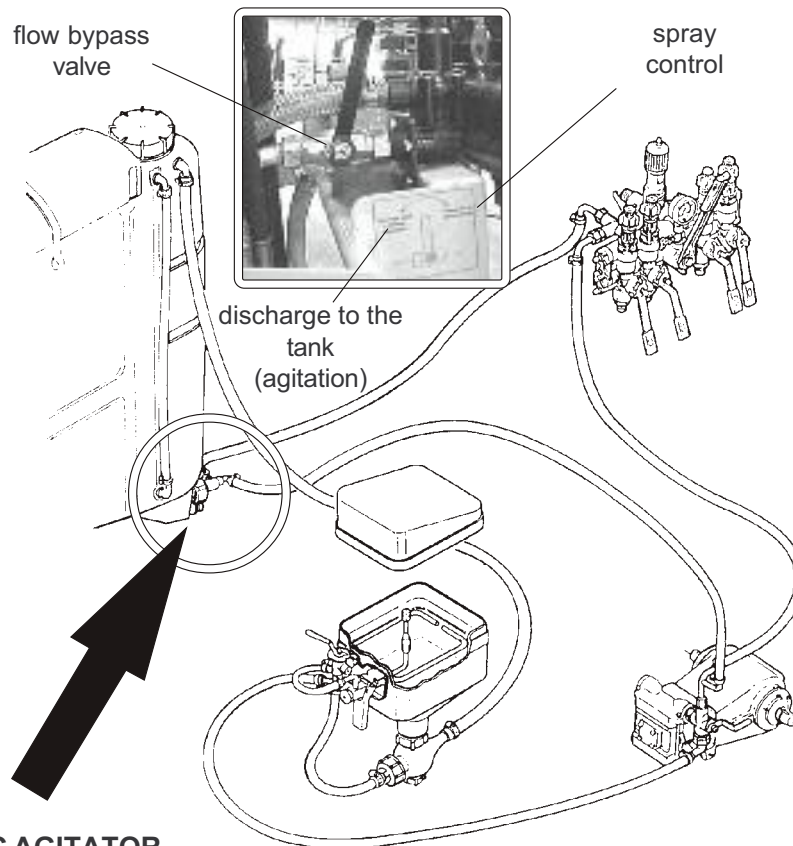

HYDRAULIC AGITATOR

The agitator operation is the same of most of hydraulic agitators, in which a water flow passes through throttling that increases its speed, and it, because of the "venturi principle" in the suction chamber, draws a great deal of water at a speed lower than the entry speed.

The difference in comparison with other agitators is that this one has two inlets. One for high flow rate (1" hose) and other for low flow rate (1/2" hose). On the low flow rate inlet, that is always in the same pressure of the nozzles, there is a ceramic tablet that provides the following flow rates for agitating the mixture:

- At a pressure of 20 psi on the circuit, around 3 L/min of chemical mixture pass by the tablet, that represents due to the venturi system the circulation of 60 L/min of chemical mixture in constant agitation.
- At a pressure of 300 psi on the circuit, around 9 L/min of chemical mixture per minute pass by the tablet, that represents due to the venturi system the circulation of 200 L/min of chemical mixture in constant agitation.

The two outlets in the system work in different situation:

- The low flow rate inlet allows a continuous agitation in any situation of operation.
- The high flow rate inlet was designed to give a better condition for agitating the chemical mixture while it is prepared and also on the way from the filling spot to the area to be sprayed.

MAIN COMPONENTS OF SPRAYER

FILLER UNIT (OPTIONAL ACCESSORY)

- Put 50 liters of water in the tank.
- Turn up the lever (1) (on the pump outlet valve). The decal affixed to the sprayer column indicates "Válvulas Superiores" ("Upper Valves").

NOTE: The lever must be turned up in order to avoid the return of the chemical mixture existing in this part of the circuit.

- Remove the hose "A" which connects the chemicals mixer valve with the chemical mixer base.
- Install the filler unit hose "B" in the place of the hose "A".
- Turn the lever (1) down (the decal affixed to the sprayer column indicates "Chemicals Mixer").
- Put the filler unit (3) in the water source and the end of its hose (4) in the tank opening.
- Engage the PTO (max. 540 rpm).
- The lever of the chemicals mixer valve (5) must be set to bypass the flow to the filler unit.

Attention: always be alert while filling the tank in order to avoid spillage of the chemical mixture onto the ground.

- After finishing the filling operation, connect the hose "A" again to the chemicals mixer valve.
- Turn up again the lever (1) - "Válvulas Superiores" ("Upper Valves").
- Set the chemicals mixer lever (5) back to the working position.

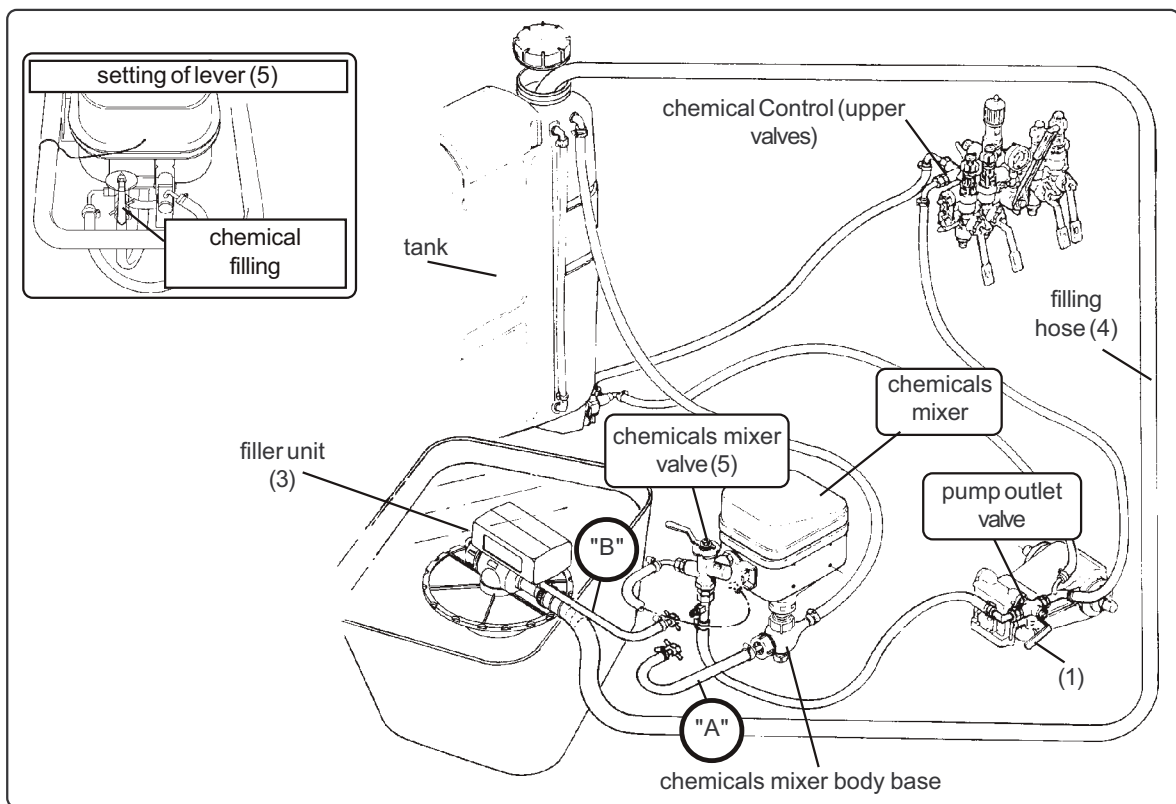

**PROTECT THE ENVIRONMENT.
IT IS EXTREMELY IMPORTANT FOR A HEALTHY LIFE.**

ATTENTION

- THE SPRAYER FILLING OPERATION MUST BE DONE IN PLACES APPROPRIATE FOR THIS PURPOSE OR THROUGH APPROPRIATE VEHICLES (TRUCKS, TRAILERS, ETC.).
- NEVER COLLECT WATER FROM RIVERS, LAKES, DAMS, STREAMS, ETC. BY USING THE SPRAYER'S RETURN SYSTEM.

MAIN COMPONENTS OF SPRAYER

FAN ROTATION ADJUSTING VALVE

This valve adjusts the oil flow to run the hydraulic motor which actuates the fan.

The maximum fan rotation is 2,200 rpm. To change the rotation, just turn the knob: clockwise to increase the rpm and counterclockwise to decrease the rpm.

Spraying grounds covered by vegetation (crops or strange plants) requires maximum rpm, while for spraying clear grounds (no crop or vegetation) it is necessary to adjust the rotation in order not to raise dust.

Another important factor is the power consumption: the lower the fan rpm, the lower the power consumption (maximum power consumption with fan at 2,200 rpm = 13 HP).

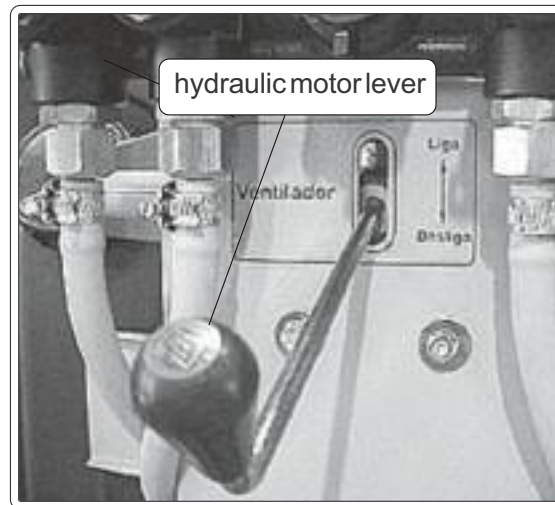

SPRAY BOOM

This boom is specifically designed to make spray applications in windy days.

The air produced by the fan is uniformly distributed along the entire boom providing better penetration of the chemicals with minimal drift level.



OPERATIONAL PROCEDURES

Stage	Procedure	Sprayer type	
		Trailer	3 point
Spraying	Use individual protective clothing	X	X
	Do not work at high speeds	X	X
	Do not spray against the wind	X	X
	Do not travel with boom lifted or unlocked	X	X
	Take care with electricity supply cables	X	X
	Do not eat, drink or smoke while spraying	X	X
	After spraying, dispose of all protective clothing and take a shower	X	X
Receiving the sprayer	Check if all components are intact	X	X
	Check the components of accessories box	X	X
	Require trained person to instruct about assembling, operating and servicing components and accessories ...	X	X
Using the sprayer for the first time	Check if the hitch pin is original	X	-
	Check if the three-point hitch pins are original	-	X
	Check if the hitch pins have cotter pins	X	X
	Check the overlaps of the PTO shaft	X	X
	Remove the tractor's drawbar	-	X
	Raise to the highest the tractor's hydraulic arms	X	X
	Adjust the control valve position to avoid impacts while turning	X	-
	Check if the grease fittings are filled	X	X
	Check if the oil is on the level on the components	X	X
	Calibrate the tires	X	-
	Retighten the tank nuts and lug nuts	X	-
Whenever filling the tank	Clean the suction or line filters	X	X
	Clean nozzles and their strainers	X	X
Every day or every 10 hours	Clean nozzles, strainers and filters	X	X
	Check the grease fittings and joint pins	X	X
	Check the oil level on the pumps and gear box	X	X
	Wash the inside and outside of the sprayer	X	X
	Check for damage on the paint and repaint	X	X
	Check for oil leakage and stop it	X	X
First 30 hours	Change for the first time the pump oil	X	X
	Retighten the bolts on the tank, axle and wheels	X	-
Every 100 hours	Change the oil of the pump and gearbox	X	X
	Tighten the belts	X	X
	Clean and check the pressure regulator components	X	X
	Clean the inside and outside of the sprayer, and paint the parts subject to corrosion with lubricating oil	X	X
Every 500 hours or annually	Service the pump	X	X
	Change hydraulic oil	X	-
	Change the oil of the gearbox	X	X
	Retighten the bolts of tank, wheels, axle, etc.	X	-
	Change the grease of the wheel hub	X	-

SETTING UP TRACTOR

ADJUSTING PARTS TO HITCH TO THE TRACTOR'S THREE-POINT SUSPENSION

ATTENTION: The instruction below is an example of what should be done for properly hitching the sprayer to the tractor's three-point suspension. To exemplify we have used the Ford 4600 tractor. However, you should proceed as directed in the operator's manual of your tractor.

TIE ARM OF THE LEFT BAR

To adjust the length of the left lift arm to the proper position, loosen the pin and turn the lower half (2) of the lift arm.

NOTE: The grease fitting (1) should point up.

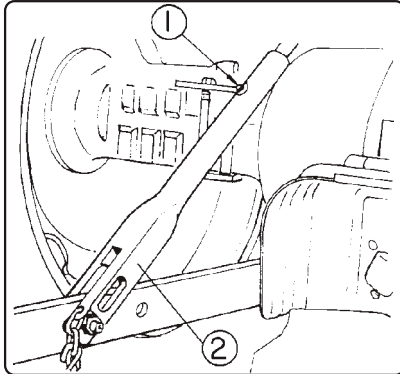

LEVELLING BOX

To adjust the transversal levelling of the sprayer, turn the crank (1) located on the levelling box.

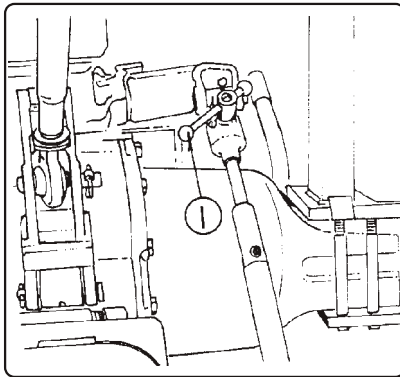

ADJUSTING THE THIRD POINT

Release the lock (1) and turn the sleeve (2) to adjust the length of the third point arm. During transport, fasten the plate of the third point bar to the pin (3) of the frame.

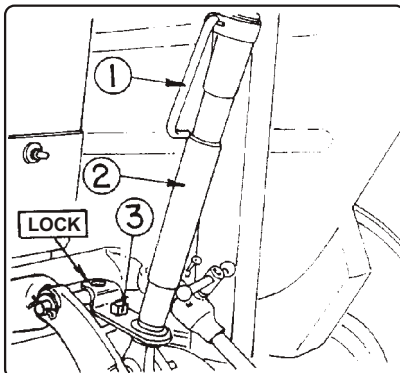

SETTING UP TRACTOR

ADJUSTING PARTS TO HITCH TO THE TRACTOR'S THREE-POINT SUSPENSION

THIRD POINT FRAME

The third point frame has two positions (1 and 2) to install the third arm and two positions (3 and 4) to install the frame lower pin.

Thus there are four different positions for this assembly.

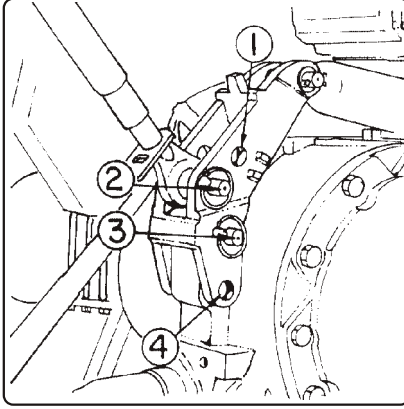

HOLES POSITION

The positions of the holes vary according to the duty to be done.

Third arm's position	Frame	Duty kind
No. 1	No. 4	Ultra-light
No. 1	No. 3	Light
No. 2	No. 4	Medium
No. 2	No. 3	Heavy

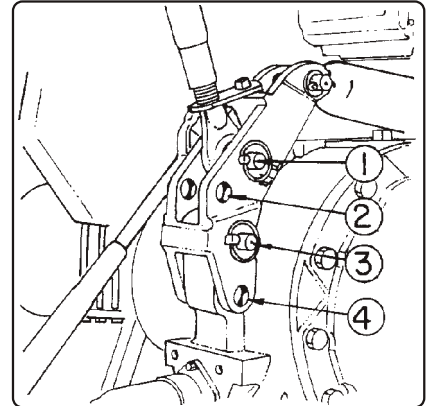

STABILIZING CHAINS

The stabilizing chains should be installed to limit the lateral movement of the sprayer hitched to the three-point system.

These chains should be adjusted according to the boom of the sprayer to be used. To adjust them, relieve the lock nut (1) and turn the adjusting nut (2), as necessary, and retighten the lock nut.

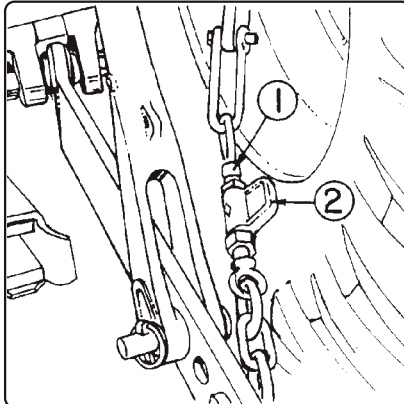

CONNECTING THE PTO

- Remove or set aside the tractor's drawbar.

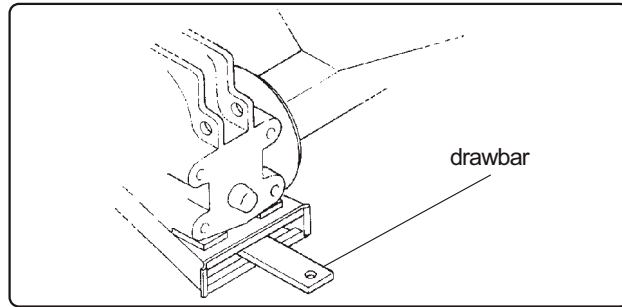

- Mount the sprayer on the tractor's three-point suspension and level it as shown in the figure beside.

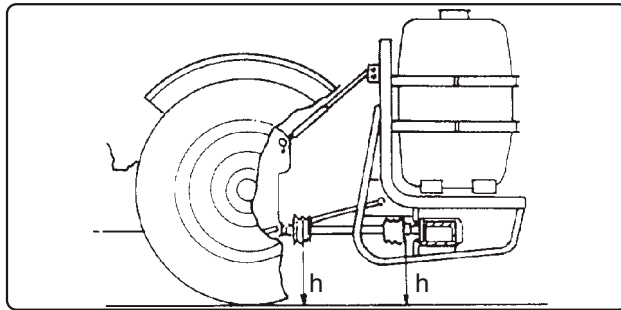

- Adjust the tractor hydraulic lift lever so that the sprayer is not raised too high.

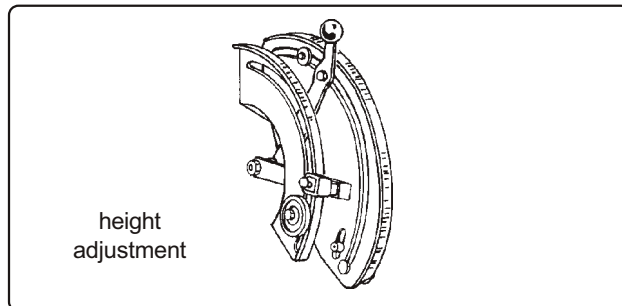

- Adjust the PTO shaft. If necessary, cut the male and female tubes so that, after connecting the sprayer, it has the overlaps recommended in the figure beside.

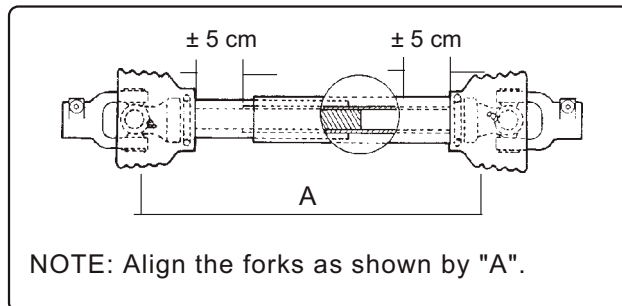

ATTENTION

- Mount all ballasts recommended by the tractor manufacturer before starting to work with the Falcon Vortex sprayer.
- Before cutting the PTO shaft tubes, check for all possibilities of movement of the sprayer on the lift arms and third point.
- Make sure the hitch pins locks are correctly installed.
- For instructions in detail, please refer to the section MAINTENANCE - PTO SHAFT.

ASSEMBLING THE ELECTRO-ELECTRONIC CONTROL

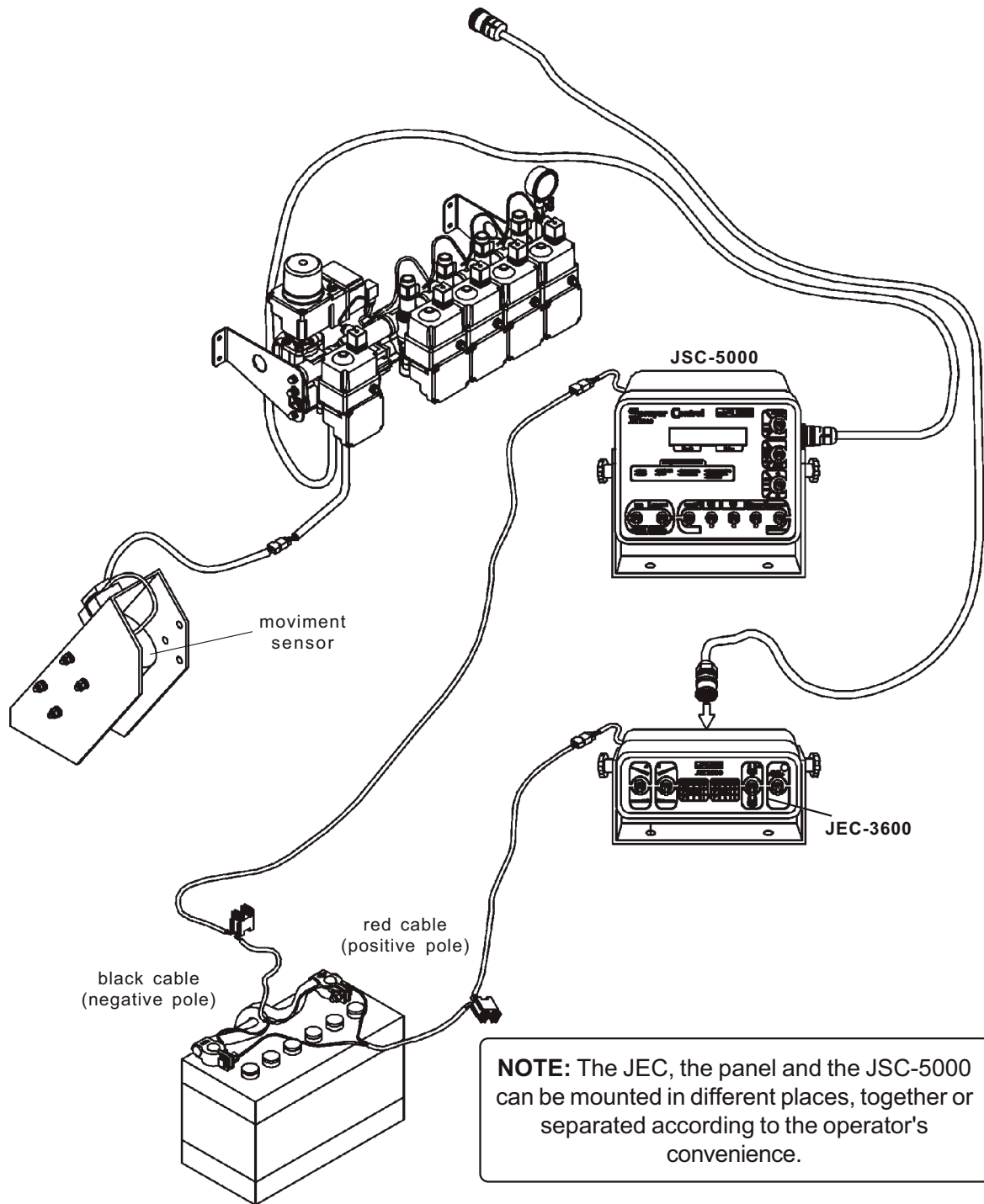

ATTENTION

- To handle batteries requires much attention since inside it there is acid liquid that causes injury to the skin eyes, clothes, etc., besides being explosive.
- Take care to not connect the negative and positive poles invertedly. Otherwise, the battery can explode.

ASSEMBLING THE BOOM

ASSEMBLING, UNFOLDING AND FOLDING THE BOOM

ATTENTION:

- Before beginning to assemble the boom and operate the hydraulic system, put clean water in the tank to prevent the operation from damaging the chemical pump.
- Only unfold and fold the boom in areas free of obstacles such as trees, electricity supply cables, etc.

ASSEMBLING THE BOOM

Hydraulic control

- Lever (1) - Operates the left boom.
- Lever (2) - Operates the frame.
- Lever (3) - Operates the right boom.

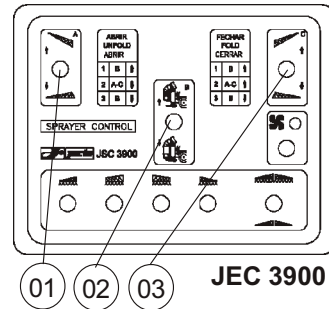
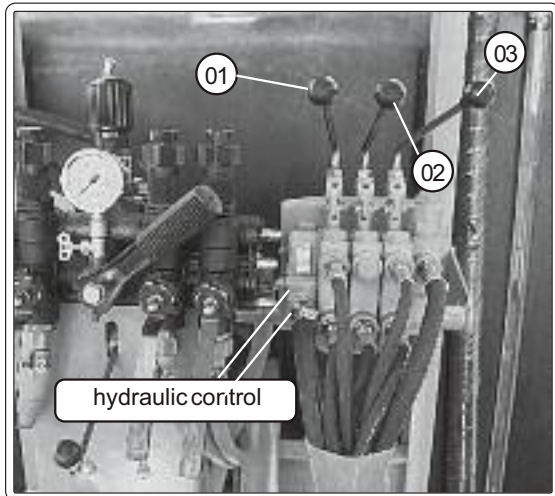

- Before assembling the boom, lower to the lowest the frame.
- Install the shaft, observing the orientation of assembling and the fitting of the flat washer with the elastic pin.

- Do the same with both right and left boom.

ATTENTION: The cotter pin should be fitted in the side opposite the air duct mounting.

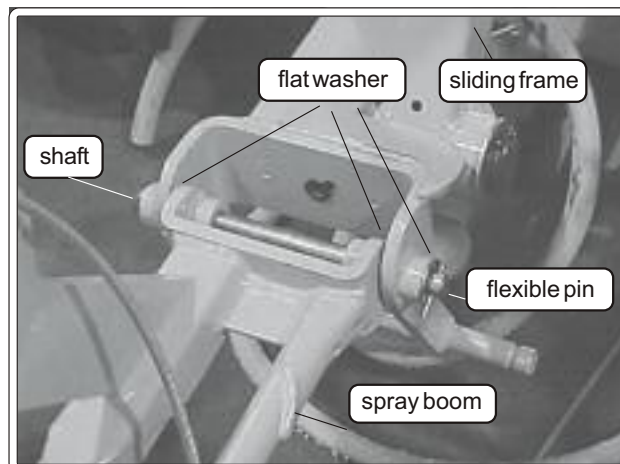

ASSEMBLING THE BOOM

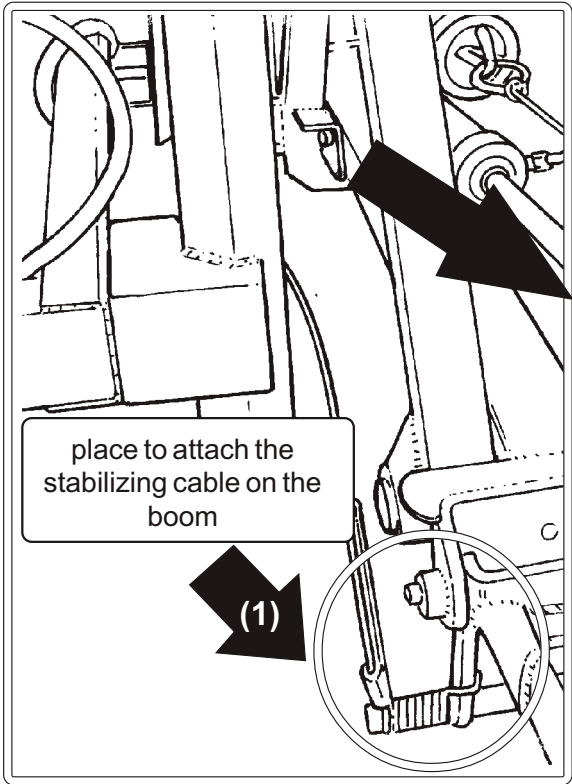

INSTALLING THE STABILIZING CABLE

- Attach the stabilizing cable to the point indicated by the arrow (1).
- Do the same on the other side.

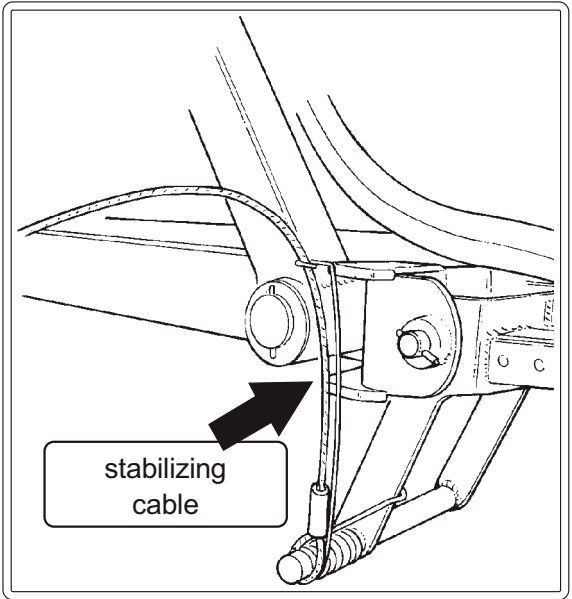
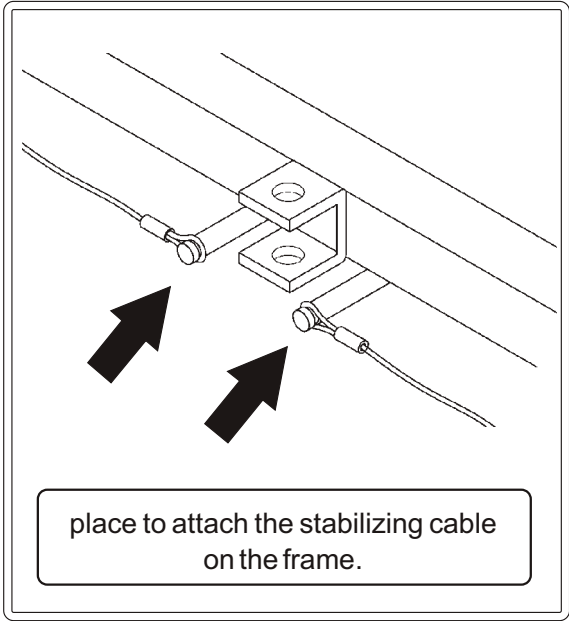

STABILIZING CABLE

Before attaching the stabilizing cable, unfold the boom and install the cable support spring.

The function of this spring is to maintain the cable suspended when the boom is unfolded.

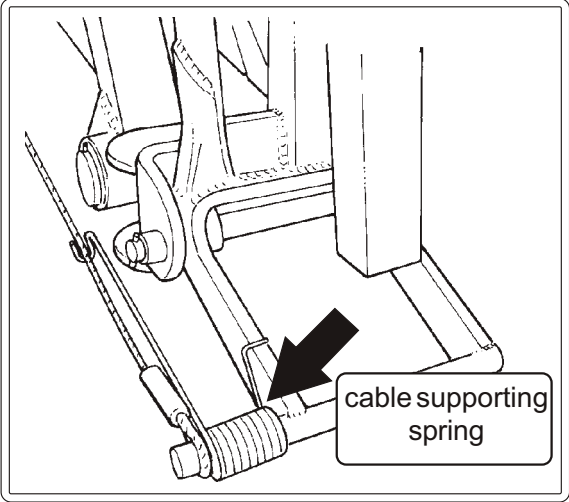

ASSEMBLING THE BOOM

- Mount the air duct protector to the boom.

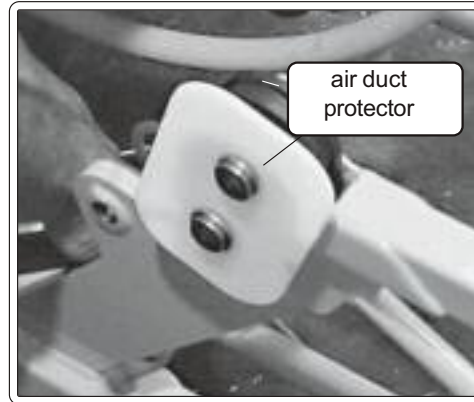

INSTALLING THE BOOM ACTUATION CABLES

- Pass the steel cable through the spring as shown in the photograph.



- Remove the spring fastening pin.
- Pass the pin through the ring on the end of the steel cable, with the spring.
- Do the same on the other side of the boom and fit the pin again.

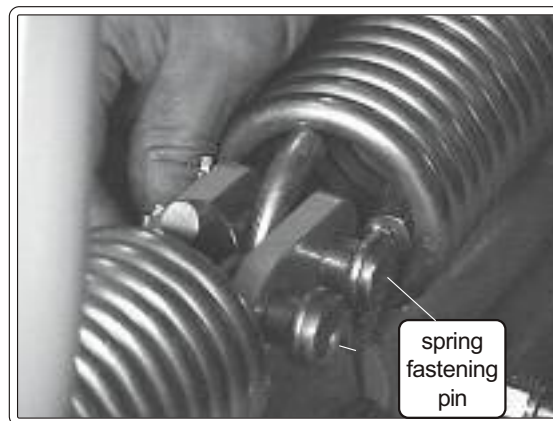

ASSEMBLING THE BOOM CYLINDER

- Move the lever 1 and 3 of the hydraulic control until the cylinder rods are completely out of the body as shown in the figure.
- Install the fastening pin in the boom.
- Repeat this operation to the other boom.

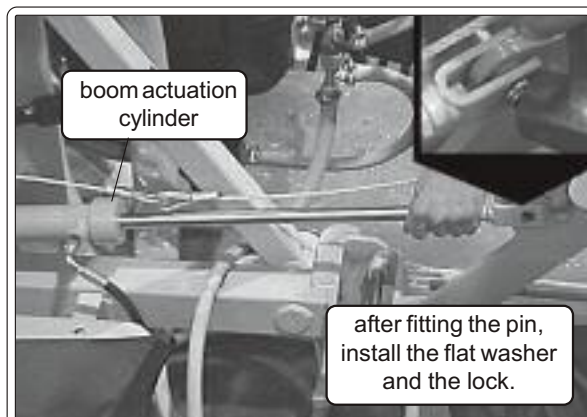

ASSEMBLING THE BOOM

INSTALLING THE BOOM STEEL CABLE

- Fold the boom, as described in the section UNFOLDING AND FOLDING THE BOOM.

NOTE: The sliding frame must be positioned around 20 cm above the base, that is to say, the frame cannot be resting on the chassis.

- Pull the boom end with your hands, trying to raise it. This operation will release the boom actuation cable.

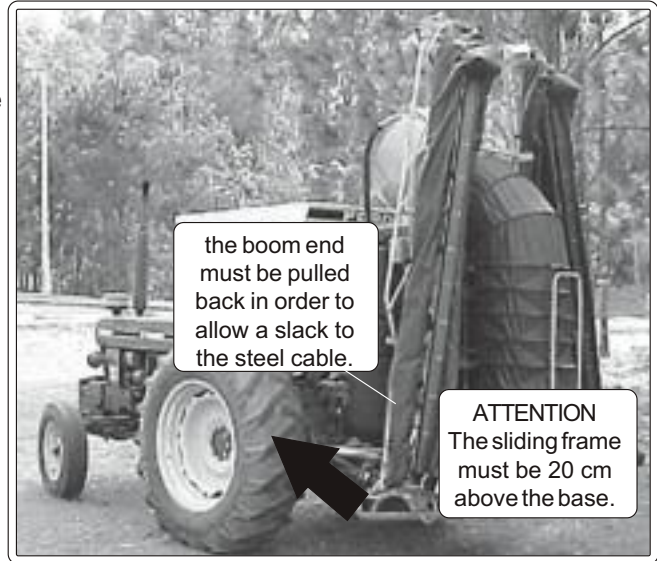

Assembling the cable

- Pass the existing ring on the operating cable of the boom extremity on the spring extremity, as shown.
- Do the same operation on the other side of the boom.

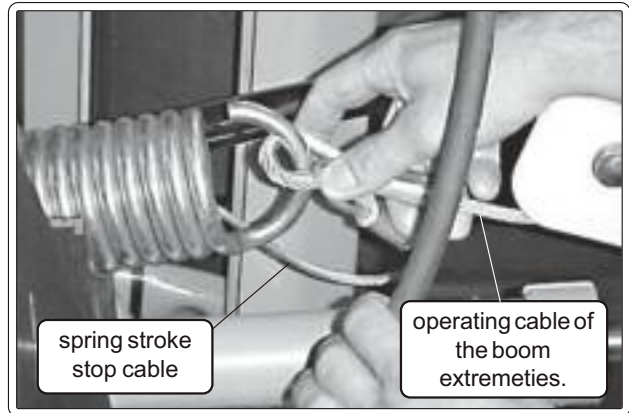

Assembling the lock on the 2nd boom section

- Lower the sliding frame all the way onto fixed frame. The boom safety lock shown in the photograph below is to be used to fasten the 1st boom section.

- To fasten the 2nd boom section, it is necessary to install the safety lock. If the lock does not fit correctly in the support, loosen the support fastening bolts until the lock fits correctly.

- Retighten the support fastening bolts.

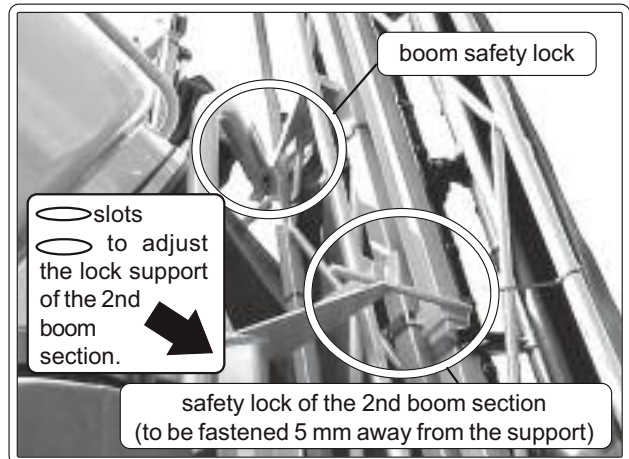

ASSEMBLING THE BOOM

INSTALLING THE HOSES

There are two hoses for each boom section. Pass them through the space showed on the drawing beside.

The hoses 1 and 2 have different lengths.

Hose (1) (shorter) must be connected to the first line filter.

Hose (2) (longer) must be connected to the second line filter.

Fasten the hoses with the clamps.

Do the same on the other boom section.

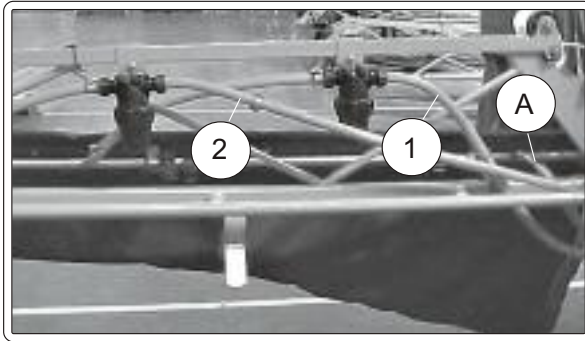
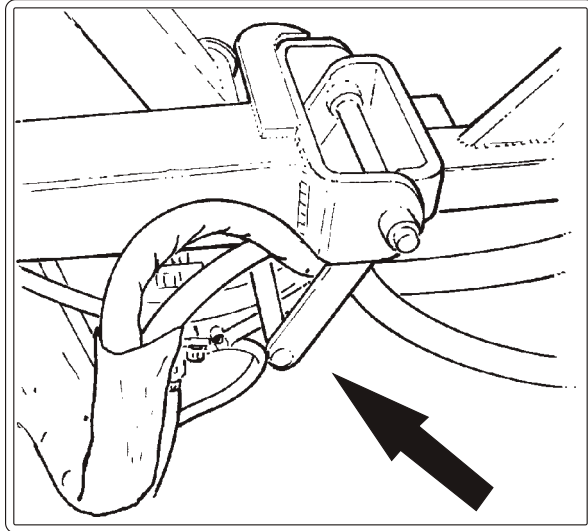

The hose of the central boom (photograph below) must be connected to the beginning of the branch on the first boom section (detail A- photograph 2568).

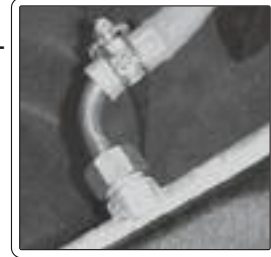

NOTE: For sprayers without line filter, the sequence for assembling is the same, that is, the shorter hose is for the first boom section, and the longer one for the second boom section.

FASTENING THE MAIN AIR DUCT TO THE BOOM AIR DUCT

The air ducts are fastened together by Velcro. To fasten them correctly, just follow the seam existing on the air duct.

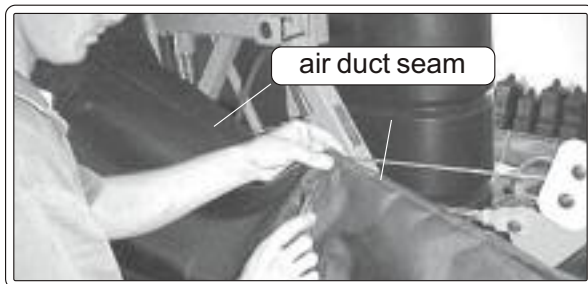

MOUNTING THE AIR DUCT TO THE DEFLECTOR

- The air duct support (1) must be screwed on the air duct support, on the upper part of the frame

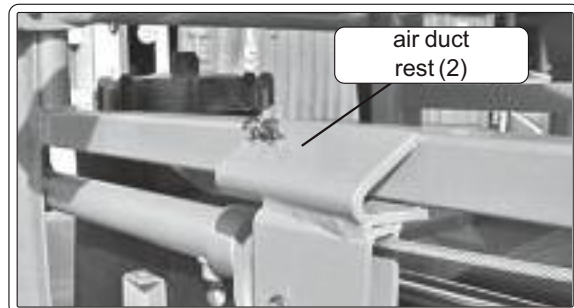
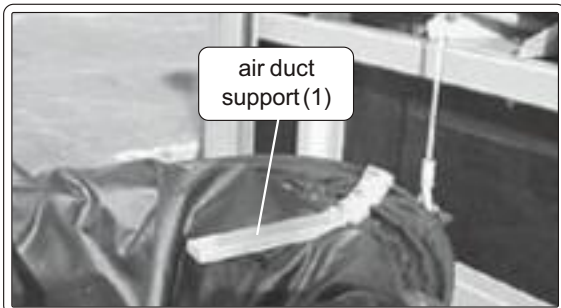

ASSEMBLING THE BOOM

- After fixing the support, fit the canvas in the deflector and fasten it with the metallic strap (3).

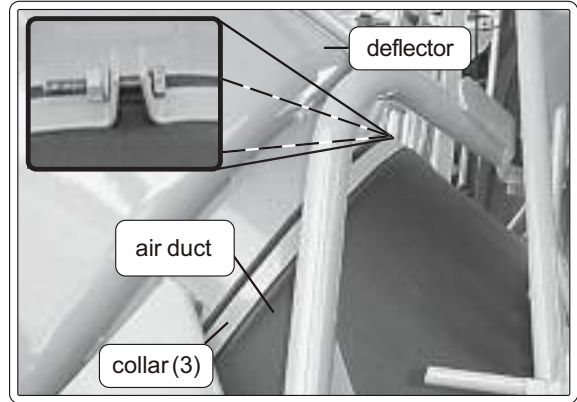
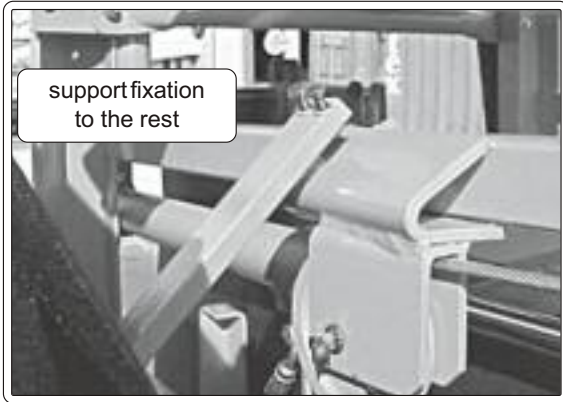

UNFOLDING AND FOLDING THE BOOM

HYDRAULIC SYSTEM OPERATION, UNFOLDING/FOLDING THE BOOM

ATTENTION:

- Before starting to operate the hydraulic system and to unfold and fold the boom, put clean water in the tank to prevent from causing any damage to the chemical pump.
- Only unfold and fold the boom in areas free of obstacles such as trees, electricity supply cables, etc.

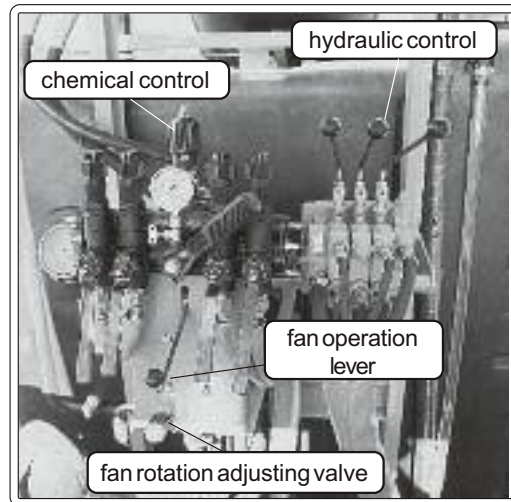

BOOM UNFOLDING AND FOLDING

The hydraulic control of your equipment can be actuated through JEC3600, JEC3900 or levers according to your purchase order.

The controls must be mounted to the tractor fender on the most convenient position to the operator. To install it, fasten a support on tractor fender and than the control.

The controls have 3 levers:

- Lever 01: raises and lower the right boom.
- Lever 02: raises and lower the frame.
- Lever 03: raises and lower the left boom.

To unfold and fold the booms, proceed as follows:

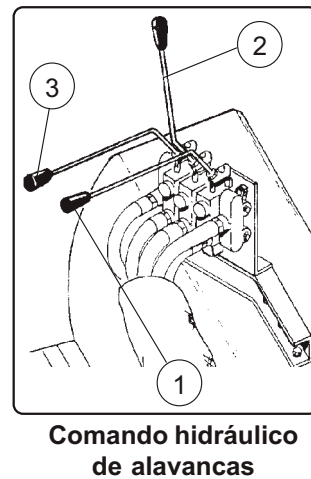
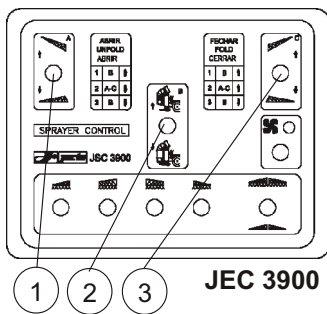

- 1st: Operates the lever (2) until the frame is lifted all the way.

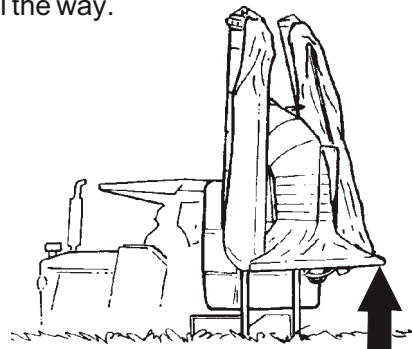

UNFOLDING AND FOLDING THE BOOM

- 2nd: Operate the lever (1) and then the lever (3) to unfold boom.

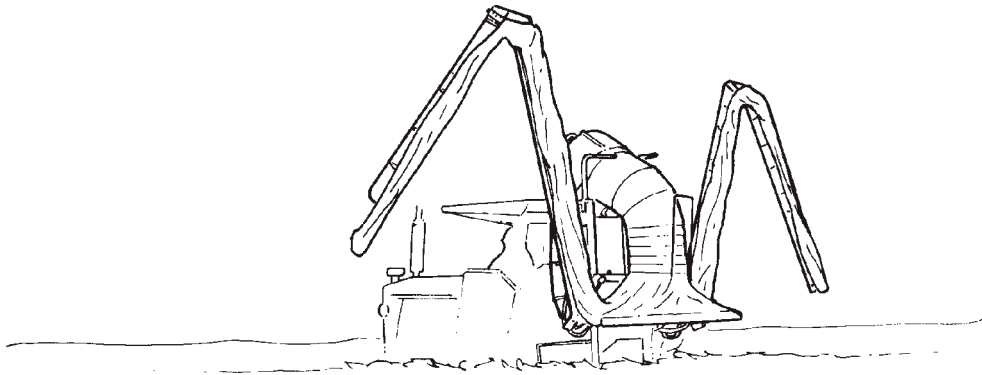

- 3rd: Continue to operate the levers (1) and (3), by keeping the boom balance, until the boom assembly is unfold all the way.

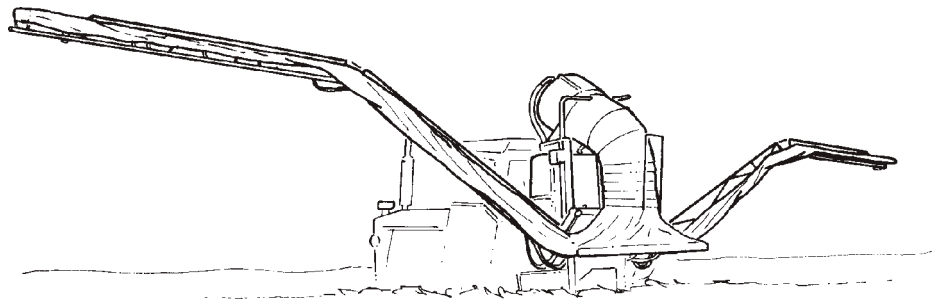

- 4th: After unfolding the boom, lower the frame all the way and keep the boom height at 50 cm over the target.

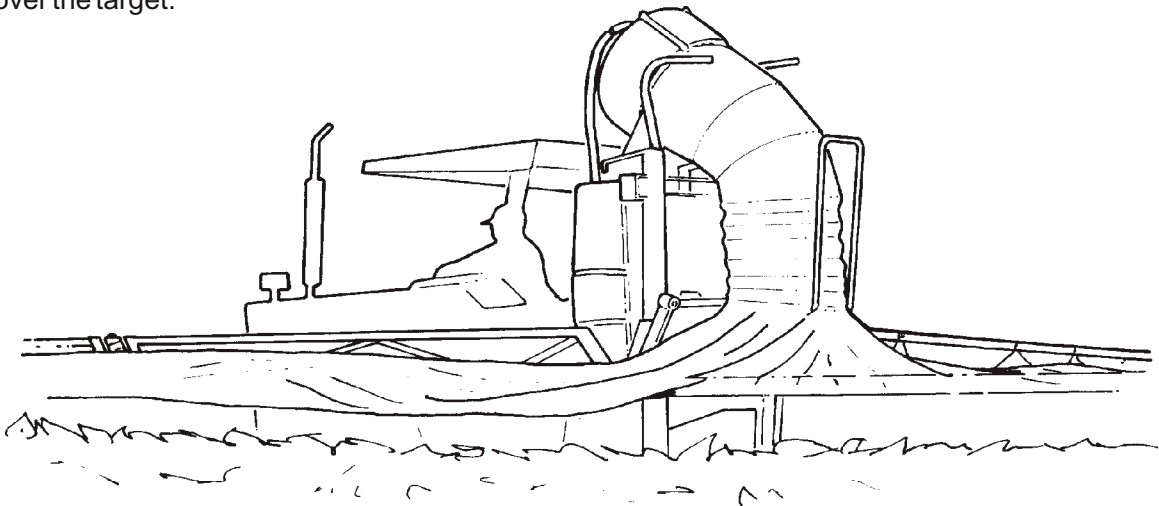

ATTENTION

- Always remove the boom before transporting the sprayer on trucks, trailers, tows, etc.
- The boom locking system is designed for normal working conditions in which the speeds developed are low.
- Always lock the boom before transporting the sprayer, even within the farm.
- Only unfold and fold the boom in areas free of obstacles such as trees, electricity supply cables, etc.

OPERATION AND ADJUSTMENTS

SPRAY APPLICATION TECHNOLOGY

A successful spray application does not depend only on a good sprayer or correct use of the chemicals but also on factors to be determined in the field under specialized orientation.

Among these factors, some concepts should be part of a criterion of evaluation so that positive results may be attained within the pest control program.

- **Ideal time**
- **Safety**
- **Sprayer operational condition**
- **Application rate**
- **Good coverage**
- **Well trained operator**

IDEAL TIME

The ideal time for spraying should be chosen according to the chemical product characteristics, as well as to the field conditions:

- Infestation level of pests, diseases and weeds;
- Infection level of diseases;
- Growing stage of weeds;
- Weather conditions.

SAFETY

When spraying your crops, you must make sure there will be no risk to people, animals and environment. Avoid spraying at hotter times, with humidity below 55% or under windy conditions. **Do not allow the operator to handle chemicals and spraying machinery without the proper individual protective clothing.**

CORRECT APPLICATION RATE

Any type of application requires that the rate be maintained during the whole spraying work. This will be possible when you have a good sprayer properly calibrated.

This calibration can be obtained through practical methods or formulas. Please refer to the section **OPERATION AND ADJUSTMENTS - CALIBRATING THE SPRAYER.**

GOOD COVERAGE

You have a good coverage when the whole target is sprayed with uniform distribution, with no risk to the environment and with good results in the pest control.

The application rate does not have influence on the treatment results. Therefore good coverages can be attained even with different rates, which may vary according to operational and regional factors.

IMPORTANT!

READ CAREFULLY AND FOLLOW STRICTLY THE INSTRUCTIONS ON THE CHEMICALS MANUFACTURER'S LABEL.

ALWAYS FOLLOW DIRECTIONS OF A TECHNICIAN WHEN HANDLING AND APPLYING CHEMICALS.

ALWAYS MAKE SURE THE SPRAYER IS IN GOOD OPERATIONAL CONDITIONS BEFORE STARTING THE SPRAYING JOB AND EMPLOY A WELL TRAINED OPERATOR.

OPERATION AND ADJUSTMENTS

MASTERFLOW CONTROL VALVE

Besides providing great sensitivity and precision in the adjustments, it has two basic functional characteristics in relation to conventional control valves.

FLOW PROPORTIONAL TO TRAVEL

In a same working gear, even if the engine rotation is changed, the volume per area sprayed remains unchanged.

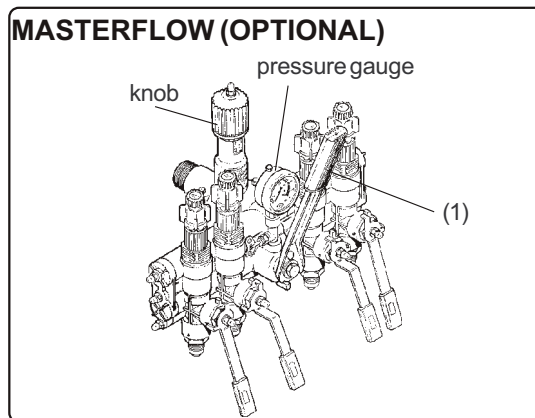

SAME PRESSURE ALONG THE WHOLE BOOM REGARDLESS OF NUMBER OF BOOM SECTIONS IN USE

It has a system that allows to calibrate the return of each boom section and keep constant the pressure, regardless of the number of boom sections turned on or off.

ATTENTION

In order to ensure longer life of the pressure gauge, close the lever (1) after regulating the sprayer, thus releasing the pressure, and close the pressure gauge valve.

OPERATING THE MASTERFLOW CONTROL VALVE

CALIBRATING THE WORKING PRESSURE:

- 01 - Engage the tractor PTO and gradually accelerate until reaching 540 rpm.
- 02 - Keep the relief lever in the position **P** (pressure) - fig. **A**.
- 03 - Turning the knob clockwise increases pressure (fig. **B**).
- 04 - Turning the knob counterclockwise decreases pressure (fig. **C**).

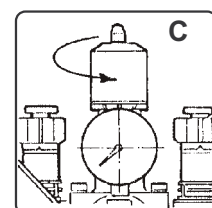
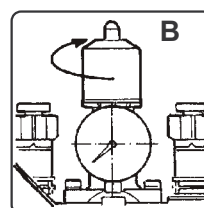
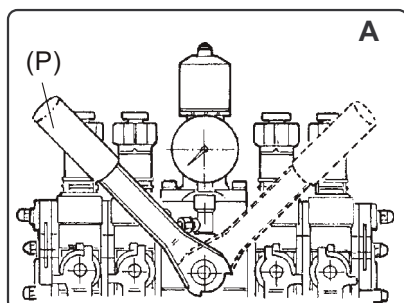

OPERATION AND ADJUSTMENTS

To calibrate every boom section, proceed as follows:

- 01 - Run the sprayer and turn on the chemical flow to all boom sections.
- 02 - Set the relief lever (1) in the position **P** [pressure].
- 03 - Set the levers (2), (3), (4) and (5) to point down.
- 04 - Check the pressure indicated by the pressure gauge.
- 05 - Choose one of the boom sections and set the lever aside all the way [to turn off].
- 06 - Other levers should remain pointing down [to turn on].

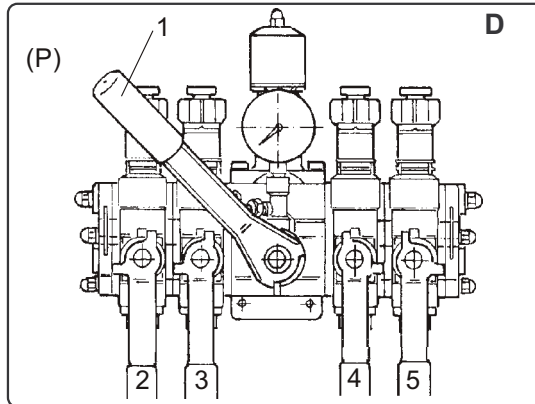

07 - Check if the pressure indicated by the pressure gauge changed. If so, proceed as follows:

- Loosen the fastening screw shown by the arrow (figure **E**).
- Turn the knob clockwise to increase the operating pressure (figure **F**).
- Turn the knob counterclockwise to decrease the operating pressure (figure **G**).

NOTE: The pressure should be equal to that previously indicated by the pressure gauge when the nozzles of this boom section were turned on.

- After calibrating the pressure gauge, set the lever back in the position "PULVERIZAR" [SPRAY] (to point down/turn on).

- Do the same on every boom sections in order to maintain constant pressure along the entire boom, regardless of the number of boom sections turned on.

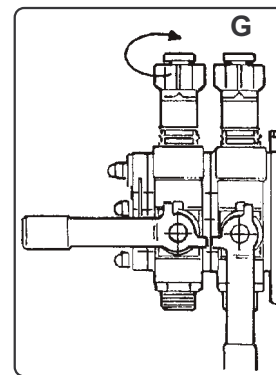
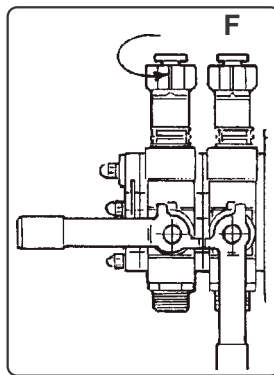
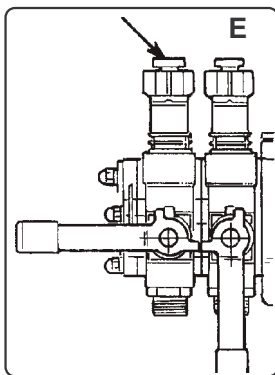

ATTENTION: Do not change the rotation while checking the nozzles flow rate. Change on the rotation will change the pressure on the nozzles and hence their flow rates.

OPERATION AND ADJUSTMENTS

HOLLOW CONE NOZZLE HIGH QUALITY CERAMIC SERIES JA

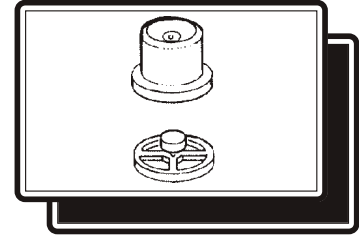

TECHNICAL CHARACTERISTICS

SPRAY PATTERN HOLLOW CONE
 SPRAY ANGLE 75 TO 80 DEGREES AT 150 PSI
 MATERIAL DE FABRICAÇÃO **SINTERED ALUMINA**
 FLOWRATE IDENTIFICATION NOZZLE COLOR AND DESCRIPTION

Series JA hollow cone nozzles are produced by processes developed for exacting markets of mechanical engineering, space and aerospace industries. A special mold injection process makes a perfect orifice on the nozzles, giving better quality to the surface finish than that achieved by machines. And the result is better coverage and more homogenous spraying.

These nozzles are approved by international quality standards, ensuring an outstanding spray cone uniformity and flow rate of nozzles.

The alumina-sintered nozzles are almost as hard as diamond and resist yet the most corrosive products. This provides perfect stability for long time concerning all requirements such as flow rate, coverage and droplet size.

TABLE 01 - FLOW RATE

Pressure (psi)	Nozzle model					
	JA - 1	JA-1.5	JA-2	JA-3	JA-4	JA-5
	Flow rate (L/min)					
30	0.23	0.31	0.47	0.64	0.91	1.16
45	0.28	0.38	0.55	0.77	1.10	1.40
60	0.32	0.43	0.64	0.88	1.25	1.60
90	0.38	0.52	0.76	1.06	1.51	1.93
120	0.42	0.59	0.86	1.21	1.72	2.20
150	0.50	0.66	1.00	1.34	1.91	2.44
180	0.52	0.71	1.04	1.46	2.07	2.65
210	0.55	0.77	1.13	1.57	2.22	2.85
240	0.60	0.82	1.22	1.68	2.34	3.22
270	0.63	0.87	1.28	1.76	2.42	3.41
300	0.72	0.90	1.42	1.84	2.54	3.57

NOZZLES STRAINERS: Use 50 or 60 mesh for all nozzle models.

OPERATION AND ADJUSTMENTS

TABLE 02 - SPRAYING VOLUME WITH NOZZLE SPACED AT 50 CM

NOZZLE		PRESSURE (psi)	FLOW RATE PER NOZZLE (L/min)	TRACTOR SPEED (km/h)								
				4	5	6	7	8	9	10	11	12
MODEL	COLOR			SPRAYING VOLUME (L/ha)								
JA-1	BLUE	60	0.32	96	77	64	55	48	43	38	35	32
		90	0.38	114	91	76	65	57	51	46	41	38
		150	0.50	150	120	100	86	75	67	60	55	50
		210	0.55	165	132	110	93	83	73	66	60	55
JA-1.5	BROWN	60	0.43	129	103	86	74	65	57	52	47	43
		90	0.52	156	125	104	89	78	69	62	57	52
		150	0.66	198	158	132	113	99	88	79	72	66
		210	0.77	231	185	154	132	116	103	92	84	77
JA-2	BLACK	60	0.64	192	154	128	110	96	85	77	70	64
		90	0.76	228	182	152	130	114	101	91	83	76
		150	1.00	300	240	200	171	150	133	120	109	100
		210	1.13	339	271	226	194	170	151	136	123	113
JA-3	ORANGE	60	0.88	264	211	176	151	132	117	106	96	88
		90	1.06	318	254	212	182	159	141	127	116	106
		150	1.34	402	322	268	230	201	179	161	146	134
		210	1.57	471	377	314	269	236	209	188	171	157
JA-4	RED	60	1.25	375	300	250	214	188	167	150	136	125
		90	1.51	453	362	302	259	227	201	181	165	151
		150	1.91	573	458	382	327	287	255	229	208	191
		210	2.22	666	533	444	381	333	296	266	242	222
JA-5	GREEN	60	1.60	480	384	320	274	240	213	192	175	160
		90	1.93	579	463	386	331	290	257	232	211	193
		150	2.44	732	586	488	418	366	325	293	266	244
		210	2.85	855	684	570	489	428	380	342	311	285

In order to achieve spraying volumes (L/ha) from nozzle spacings other than 50 cm, multiply the values of the table 2 by the conversion unit indicated below.

Nozzle spacing (cm)	20	25	30	35	40	45	50	55	60	65	70	75
Conversion unit	2.50	2.00	1.67	1.43	1.25	1.11	1.00	0.91	0.83	0.77	0.71	0.66

ORDERING: Specify nozzle model and part #. Ex.: nozzle JA-2, part # 000026.

Color	Blue	Brown	Black	Orange	Red	Green
Model	JA-1	JA-1.5	JA-2	JA-3	JA-4	JA-5
Part #	109744	454256	000026	454264	454272	454280

OPERATION AND ADJUSTMENTS

CERAMIC NOZZLES SERIES AXI-110

They are low pressure and low drift ceramic nozzles for precision spraying.

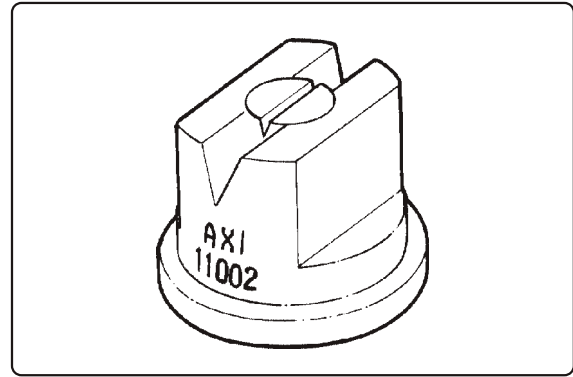

These new nozzles are available in the following versions:

- 1 - AXI 110.015 (GREEN)
- 2 - AXI 110.02 (YELLOW)
- 3 - AXI 110.03 (BLUE)
- 4 - AXI 110.04 (RED)
- 5 - AXI 110.05 (BROWN)

The flat fan nozzles of Series AXI-110, made of alumina (ceramic), produce a 110° spray angle at 15 psi. At lower pressures (15 psi), drift is reduced by generating large droplets, thus maintaining an excellent deposition pattern.

At higher pressures (40 psi), these nozzles provide better penetration and coverage with small droplets. (maximum working pressure: 60 psi)

WEAR RESISTANCE

The ceramic nozzles are very resistant to wear. According to tests performed by Oregon State University, U.S.A., they proved to have useful life of 1,000 hours at least.

UNIFORM FLOW

The nozzles of Series AXI-110 are made in accordance with an ISO proposal and provide extraordinary flow uniformity.

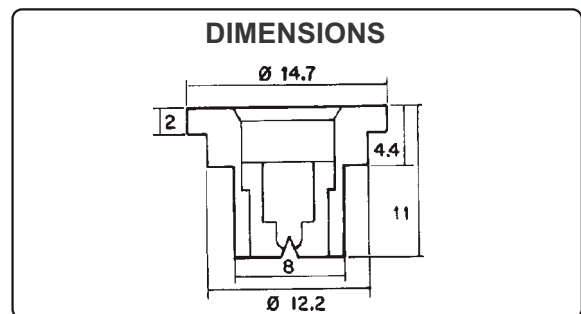
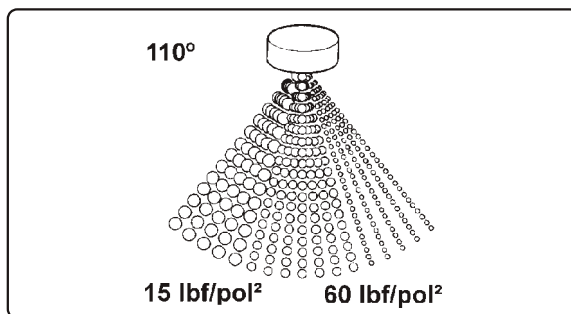

ATTENTION: The spraying volume values were calculated with nozzles spaced at 50 cm.

In order to achieve spraying volumes (L/ha) from different nozzle spacings, multiply the values of the spraying volume table in the next page by the conversion unit indicated below.

Nozzles spacing (cm)	20	25	30	35	40	45	50	55	60	65	70	75
Conversion unit	2.50	2.00	1.67	1.43	1.25	1.11	1.00	0.91	0.83	0.77	0.71	0.66

OPERATION AND ADJUSTMENTS

PRESSURE (psi)	NOZZLES FLOW RATE (AXI -110)					ORDERING	
	GREEN	YELLOW	BLUE	RED	BROWN	NOZZLE MODEL	NOZZLE PART #
	Flow rate (L/min)						
15	0.35	0.51	0.72	0.96	1.23	AXI 110.015 AXI 110.02 AXI 110.03 AXI 110.04 AXI 110.05	838862 838870 838888 838896 838904
20	0.41	0.58	0.82	1.10	1.45		
25	0.45	0.64	0.91	1.20	1.60		
30	0.50	0.70	1.00	1.33	1.75		
35	0.53	0.75	1.03	1.44	1.88		
40	0.57	0.80	1.10	1.55	2.03		
45	0.60	0.84	1.18	1.63	2.15		

SPRAYING VOLUME WITH NOZZLES SPACED AT 50 CM

NOZZLE		PRESSURE (psi)	NOZZLE FLOWRATE (L/min)	TRACTOR SPEED (km/h)								
MODEL	COLOR			4	5	6	7	8	9	10	12	14
		SPRAYING VOLUME (L/ha)										
AXI 110.015 (80 mesh)	GREEN	15	0.35	105	84	70	60	52	47	42	35	30
		20	0.41	123	98	82	71	61	55	49	41	35
		25	0.45	135	108	90	77	67	60	54	45	38
		30	0.50	150	120	100	86	75	67	60	50	43
		35	0.53	159	127	106	91	79	71	64	53	45
		40	0.57	171	137	114	98	85	76	68	57	49
		45	0.60	180	144	120	103	90	80	72	60	51
AXI 110.02 (80 mesh)	YELLOW	15	0.51	153	122	102	87	76	68	61	51	44
		20	0.58	174	139	116	99	87	77	70	58	50
		25	0.64	192	154	128	110	96	85	77	64	55
		30	0.70	210	168	140	120	105	93	84	70	60
		35	0.75	225	180	148	128	112	100	90	75	64
		40	0.80	240	192	160	137	120	107	96	80	68
		45	0.84	252	202	168	144	126	112	101	84	72
AXI 110.03 (50 mesh)	BLUE	15	0.72	216	173	144	123	108	96	86	72	62
		20	0.82	246	197	164	140	123	109	98	82	70
		25	0.91	273	218	182	156	136	121	109	91	78
		30	1.00	300	240	200	171	150	133	120	100	86
		35	1.03	309	247	206	176	154	137	124	103	88
		40	1.10	330	264	220	188	165	147	132	110	94
		45	1.18	354	283	236	202	177	157	142	118	101
AXI 110.04 (50 mesh)	RED	15	0.96	288	230	192	164	144	125	115	96	82
		20	1.10	330	264	220	188	165	147	132	110	94
		25	1.20	360	288	240	206	180	160	144	120	103
		30	1.33	399	319	266	228	199	177	160	133	114
		35	1.44	432	346	288	247	216	192	173	144	123
		40	1.55	465	372	310	266	232	207	186	155	133
		45	1.63	489	391	326	279	244	217	196	163	140
AXI 110.05 (50 mesh)	BROWN	15	1.23	369	295	246	211	184	164	148	123	105
		20	1.45	435	348	290	248	217	193	174	145	124
		25	1.60	480	384	320	274	240	213	192	160	137
		30	1.75	525	420	350	300	262	233	210	175	150
		35	1.88	564	451	376	322	282	251	226	188	161
		40	2.03	609	487	406	348	304	271	244	203	174
		45	2.15	645	516	430	368	322	287	258	215	183

OPERATION AND ADJUSTMENTS

CALIBRATING THE SPRAYER

The safety of people, animals and environment depends on correct spray applications. Therefore, we list below important operational procedures.

WHEN HANDLING CHEMICALS

- Follow strictly the instructions on the labels.
- Use individual protective clothing recommended.
- Do not eat, drink or smoke.
- Choose a ventilated place.
- Wash with water and soap the parts of the body touched by chemicals.

WHEN OPERATING SPRAYER

- Check for the proper working conditions of the sprayer.
- Do not blow by mouth nozzles, valves or tubes.
- Do not spray upwind.
- Do not spray at sunny times
- Use individual protective clothing recommended.
- Do not eat, drink or smoke.

REMEMBER!

You are responsible for the success of the application.

PROCEDURE

The sprayer can be calibrated through the formula below.

CALCULATING THE SPRAY VOLUME

$$V = \frac{F \times 600}{S \times A} \text{ (L/ha)}$$

Where:

V : Spraying volume (L/ha)

F : Nozzle flow rate (L/min)

A : Nozzle spacing (m)

S : Tractor speed (km/h)

600 : Conversion unit

EXAMPLE

Nozzle flow rate 0.80 L/min at 40 psi (AXI-110.02)

Nozzle spacing 0.50 m

Operating speed 4.0 km/h

$$V = \frac{F \times 600}{S \times A} \text{ (L/ha)} \quad V = \frac{0.80 \times 600}{0.5 \times 4} \text{ (L/ha)} \quad V = \frac{480}{2} = 240 \text{ L/ha}$$

ATTENTION

The numbers shown in above example are illustrative. The correct calibration should be done according to the instructions of a technician.

OPERATION AND ADJUSTMENTS

CALIBRATING THE SPRAYER WITH THE CALIBRATOR BOTTLE

BEFORE CALIBRATING THE SPRAYER CHECK THE FOLLOWING:

- Suction filter: dirt;
- Hoses: twisted or bored;
- Pressure regulator components (valve seat, valve and spring): wear or dirt;
- Pump: proper lubrication (oil level and grease) and leakages;
- Nozzles: same model, wear, flow rate, strainers.

AFTER CHECKING, PROCEED WITH THE CALIBRATION AS FOLLOWS

- 1 - Mark off 50 meters on the ground to be sprayed.
- 2 - Fill the sprayer's tank.
- 3 - Choose the operating gear.
- 4 - Engage the PTO.
- 5 - Accelerate until reaching 540 rpm at the PTO.

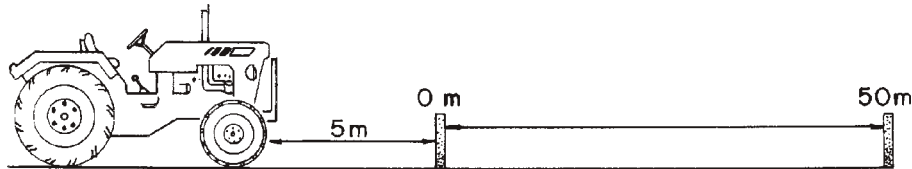

- 6 - Start moving at least 5 meters before the initial mark.
- 7 - Note the time it takes the tractor to travel 50 meters.
- 8 - On irregular terrain, repeat this operation several times and take the average.
- 9 - Stop the tractor with the acceleration used to travel the 50 meters, open the nozzles and adjust the pressure according to the recommendation for the different types of nozzles:
 - Cone nozzles : from 45 to 200 psi
 - Flat fan nozzles : from 15 to 60 psi
- 10 - Use the calibrator bottle to collect the nozzle spraying volume during the same time taken to travel the 50 meters, and read on the column corresponding to the nozzle spacing.

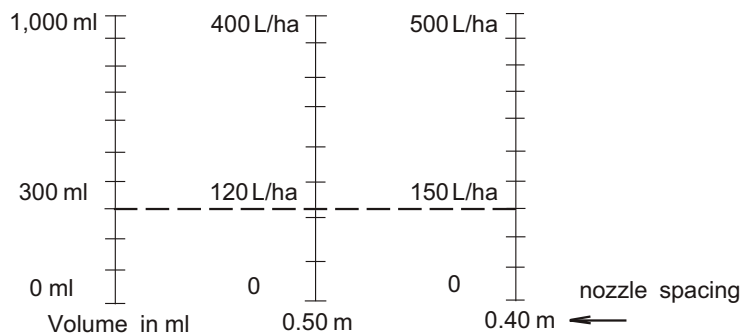

- 11 - Repeat this operation with several nozzles to obtain an average volume.

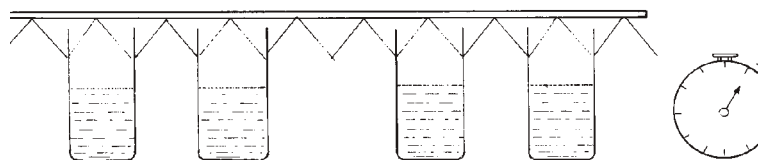

- 12 - The average obtained will be the spraying volume for the gear and pressure already determined.

NOTE: 1° - If the spraying volume obtained is below that wished, increase the pressure, decrease the speed (but 540 rpm at PTO) or change the nozzles for others of higher flow rate.

2° - If the spraying volume is above that wished, decrease the pressure, increase the speed (but keep 540 rpm at PTO) or change the nozzles for others of lower flow rate.

OPERATION AND ADJUSTMENTS

DILUTING THE CHEMICALS

ATTENTION

NEVER run the sprayer for long time with less than 50 liters of water in the tank to avoid damage to the pump.

Always use the following individual protective clothing when handling chemicals:

- Impermeable wide-brimmed hat
- Goggles
- Mask
- Long-sleeved working clothes
- Impermeable gloves
- Impermeable boots

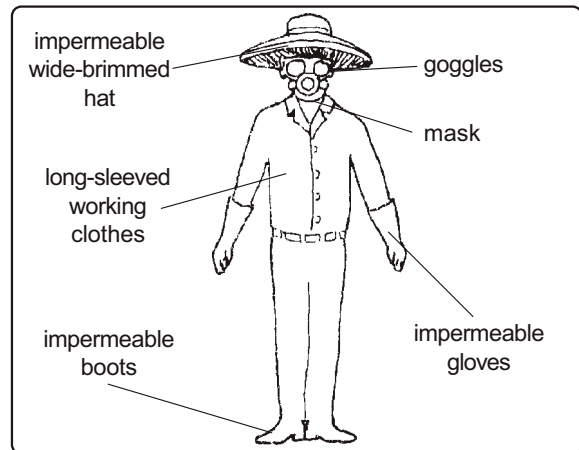

PREPARING THE CHEMICAL MIXTURE

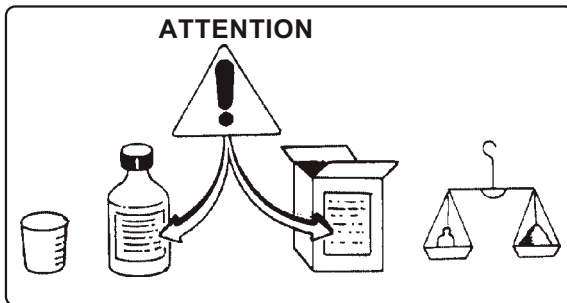

- Read carefully the chemicals manufacturer's label.

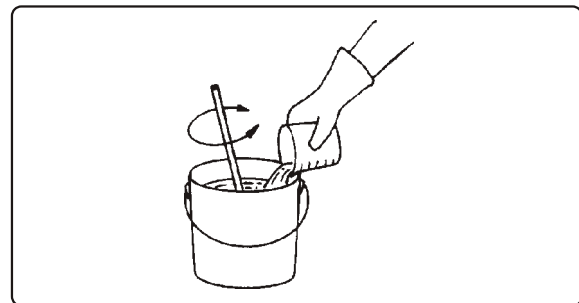

- Pour the chemical product into a bucket with little water and stir.

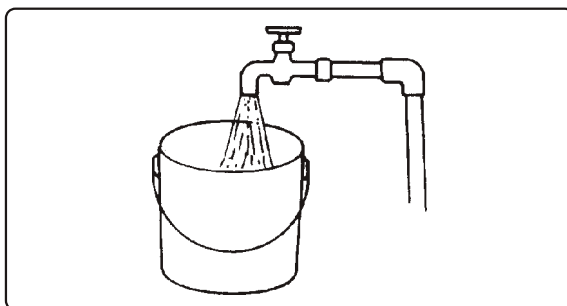

- Add water until filling the bucket up.
- Stir until the mixture is homogeneous.

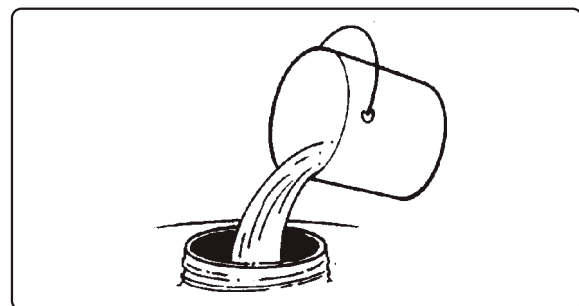

- Pour the solution into the sprayer's tank.
- Install the tank lid and make sure there is no leakage.

ATTENTION
ALWAYS FOLLOW TECHNICAL RECOMMENDATIONS
WHEN HANDLING CHEMICALS.

MAINTENANCE

GUIDELINES

- Daily, after finishing the spraying, put clean water on the tank, remove the nozzles and run the sprayer till empty.
- Remove, clean and replace the nozzles and the filters.
- Clean the main filter.
- Wash the outside and inside of the sprayer.

These procedures will avoid problems with the sprayer in future application such as : obstruction of the filters, nozzles, extensions and ducts, as well as protect your llife.

ATTENTION: NEVER WASH SPRAYERS OR PROTECTIVE CLOTHING (MASK,GLOVES, WORKING CLOTHES, ETC.) IN OR CLOSE TO RIVERS, LAKES, STREAMS, BROOKS, DAMS, ETC.

- Take off and wash all the individual protective equipment.
- Wash the working clothes separately from other clothes.
- Take a shower with plenty of water and soap and put clean clothes.

COMPONENTS MAINTENANCE

MAIN FILTER

- The frequency of filter cleaning depends on the quality of water and type of chemicals used.
- Clean the filter when filling the tank or whenever necessary.

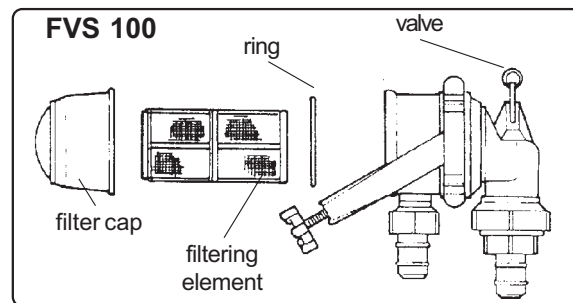

IN-LINE FILTER (SPRAYER FALCON VORTEX)

- There is one in-line filter for each boom section.
- This filter has 80 mesh and optimizes the filtration to the nozzles.
- The frequency of filter cleaning depends on the quality of water and type of chemicals used.
- Clean the filter when filling the tank or whenever necessary.

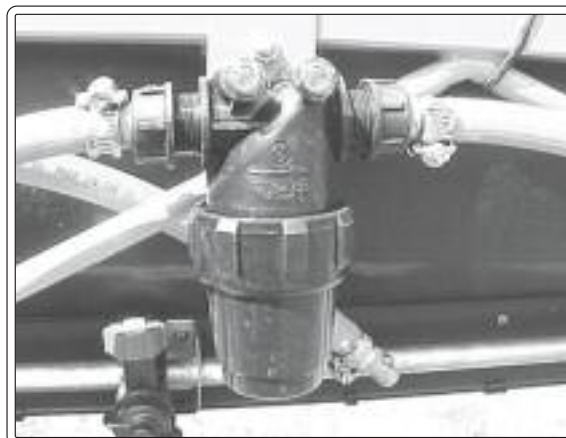

MAINTENANCE

PRESSURE REGULATOR

- Disassemble the pressure regulator every 100 working hours.
- Check for wear on the valve and valve seat. Replace parts if necessary.

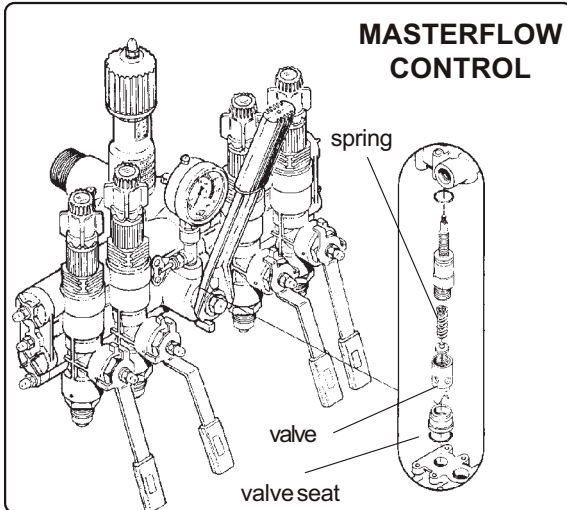

HYDRAULIC AGITATOR (TABLET)

- It is recommended to change the ceramic tip of the hydraulic agitator every 1000 hours. However, it depends of the abrasion rate of the chemicals used. It is important to check the condition of the tablet whenever checking the nozzles. Also, always replace the tablets whenever replacing the nozzles.

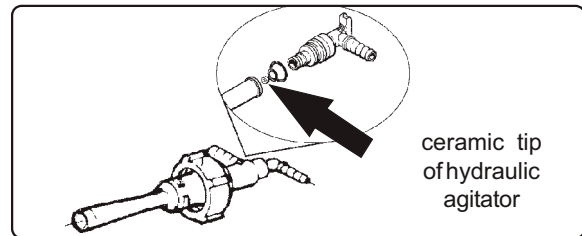

Whenever there is lack of pressure in the circuit, check:

- Damage on the hydraulic agitator.
- The flow bypass valve can be deviating the flow to the agitator.

HYDRAULIC PUMP BELT TENSION

- Loosen the nuts of the bearing base. Next, slide the pump back until obtaining the tension required for the perfect operation of the system.
- Then, retighten the nuts of the bearing base.

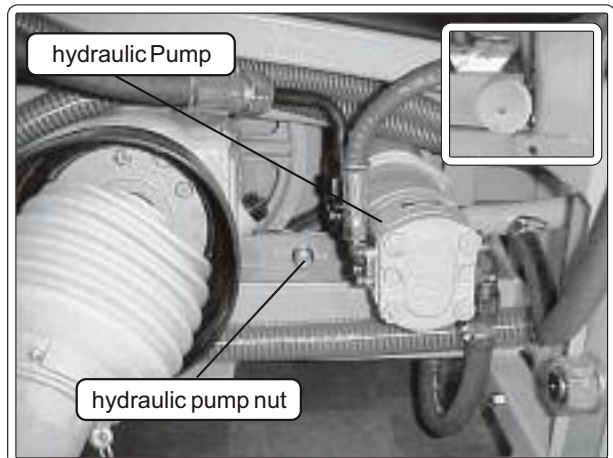

BOOM JOINT

- The boom end adjusts through the nut and lock nut. This adjustment must be made if the boom end is moving with the normal travel of the sprayer, without even touching any obstacle, or when it is very heavy, making difficult the movement upon impact against obstacles.

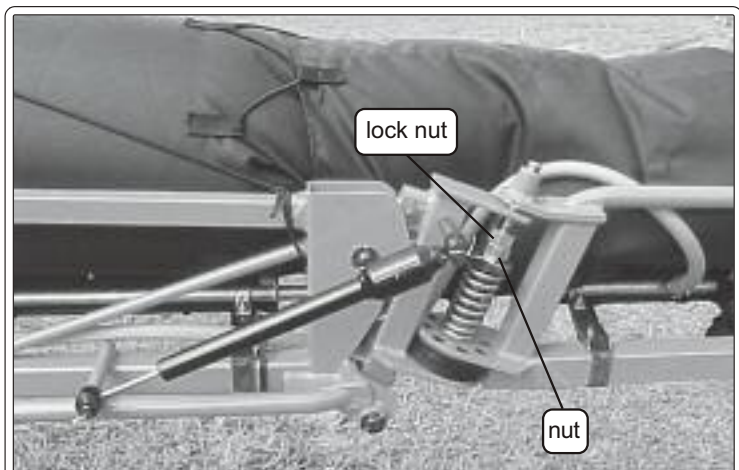

MAINTENANCE

DOUBLE NOZZLE HOLDER

(MODEL BIJET)

After prolonged use, it may be necessary to service the nondrip valve. Please refer to the drawing beside and table below.

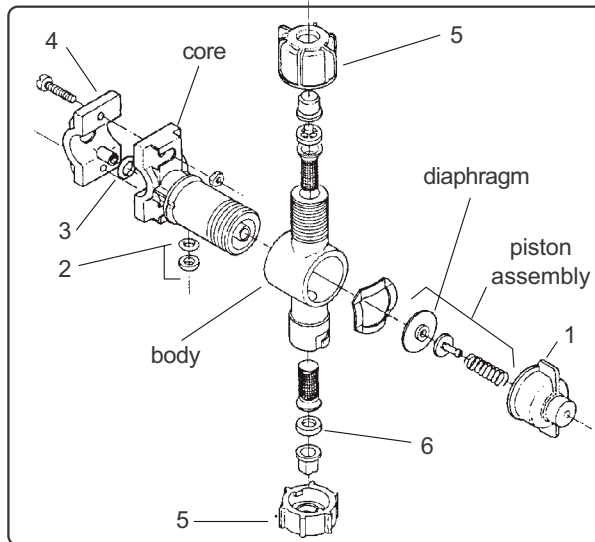

PROBLEM	CAUSE	CORRECTION
Valve does not seal.	a - Nut (1) not tightened properly. b - Impurities on the diaphragm. c - Rupture of the diaphragm. d - Rupture of the diaphragm followed by chemicals buildup.	a - Tighten the nut (1). b - Remove and clean the diaphragm. c - Replace the diaphragm. d - Replace the diaphragm and clean the piston assembly
Leakage between the nozzle holder core and body.	a - Seal (2) missing. b - Seal (2) damaged. c - Nut (1) not tightened properly.	a - Fit the seal (2). b - Replace the seal (2). c - Tighten the nut (1).
Leakage through the connection with the spray tube.	a - Packing ring (3) missing. b - Packing ring (3) damaged. c - Part (4) not tightened properly.	a - Fit the packing ring (3). b - Replace the packing ring (3). c - Tighten the part (4).
Leakage through the nozzle holder body and the nozzle.	a - Nut (5) not tightened properly. b - Base of strainer (6) damaged.	a - Tighten the nut (5). b - Replace the strainer (6).

NOZZLES

- Clean the nozzles daily or whenever there is failure in the spray.

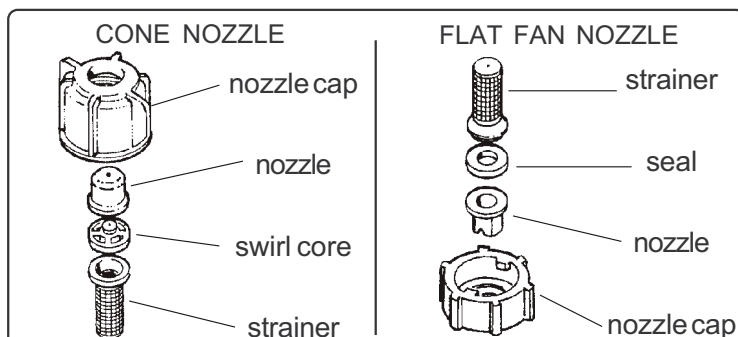

ATTENTION

The flat fan nozzle (red) has is composed of a material subject to crush to facilitate sealing.

Therefore the use of screw nozzle cap is not recommended.

MAINTENANCE

LUBRICATION TABLE

PRODUCT	COMPONENT	QTY.	FREQUENCY	SPECIFICATIONS	RECOMMENDED PRODUCTS
LUBRICATING OIL	JP-75PUMP	1.5 liter	1ST CHANGE: 30 HOURS FURTHER CHANGES: EVERY 100 HOURS	API - SB OR SUPERIOR SAE - 30	ALL INTERNAL COMBUSTION ENGINES WITHIN THIS SPECIFICATION
HYDRAULIC OIL	HYDRAULIC OIL RESERVOIR	45 liters	500 HOURS	ISO - VG - 68	RANCO HD-68 (TEXACO) DTE-25 (MOBIL OIL) TELLUS T-68 AND TELLUS 68 (SHELL)
FILTERING ELEMENT	HYDRAULIC ENGINE	01	1ST CHANGE: 50 HOURS FURTHER CHANGES: EVERY 250 HOURS	FR24-10-12N	HDA
GREASE	PTO SHAFT GREASE NIPPLES BOOM JOINT	-	DAILY	LITHIUM BASE GREASE NGLI - 2	MULTIFAKEP - 2 MOBIL GREASE 77 LUBRAX GMA - 2 BEACON EP - 2 AND SIMILAR PRODUCTS
	SLIDING FRAME GUIDE		100 HOURS		

NOTE: The presentation order of recommended products does not imply any preference for mark or product.

LUBRICATION POINTS

ATTENTION: ALWAYS STOP THE SPRAYER AND TURN OFF THE TRACTOR'S ENGINE BEFORE SERVICING.

LUBRICATING OIL/GREASE

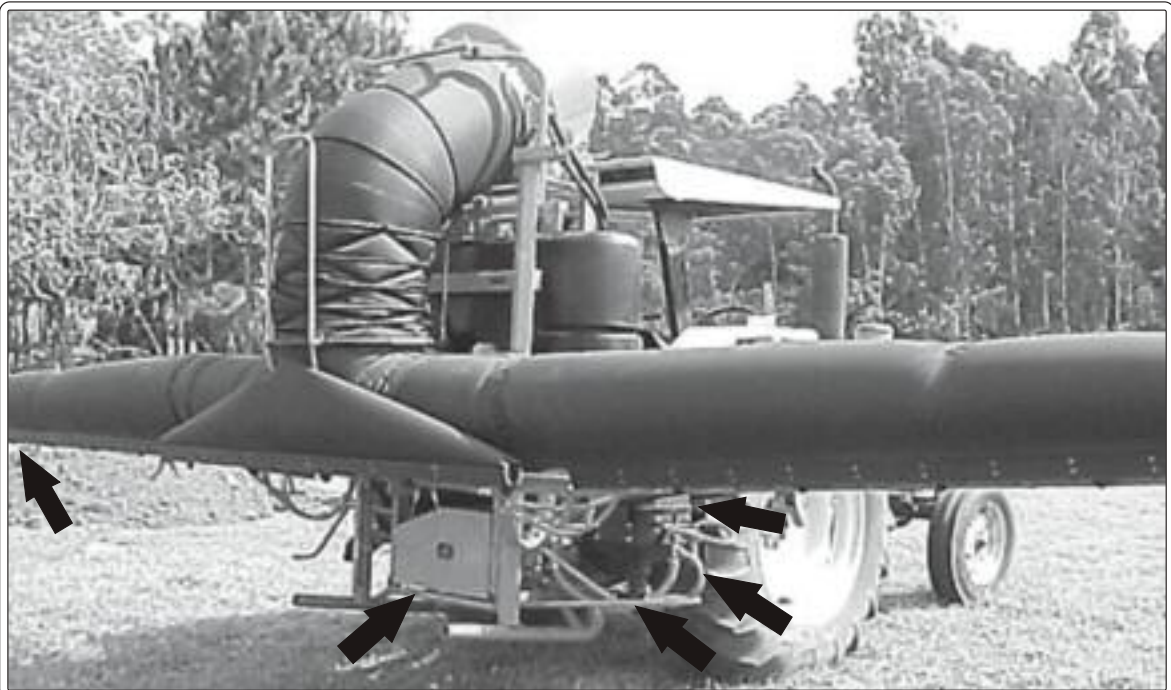

LUBRICATING OIL CHEMICAL PUMP

- Check the chemical pump oil level daily.
- Fill up if necessary.
- Use oil SAE30, normally found in gas station.

BOMBA JP - 75

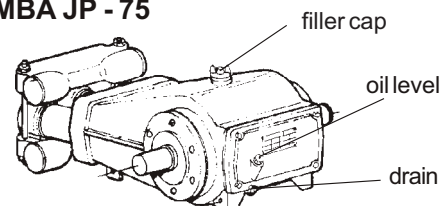

MAINTENANCE

LUBRICATING OIL

Lubricate with grease wherever there is a grease nipple. Lubricate with lubricating oil wherever there is a joint pin or shaft.

- Boom joint.
- Boom end breakaway .
- Sliding frame guide (it must be greased regularly).
- PTO shaft.

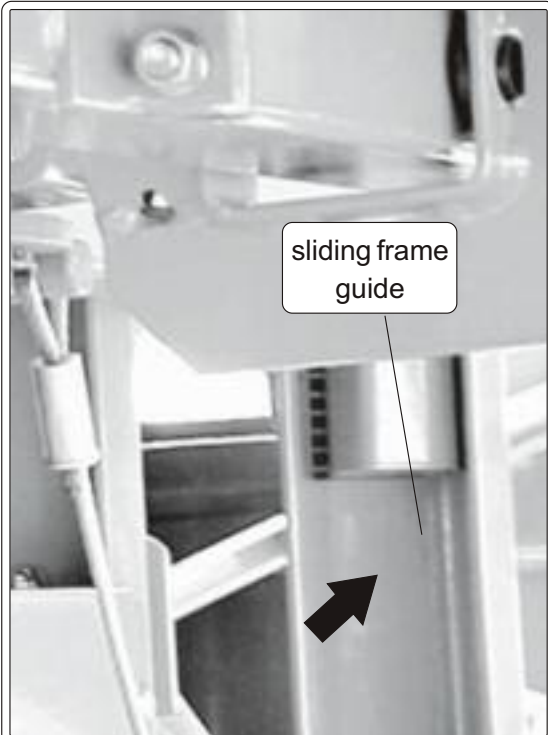
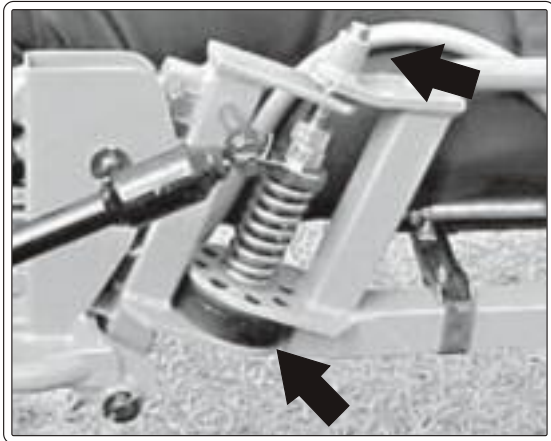
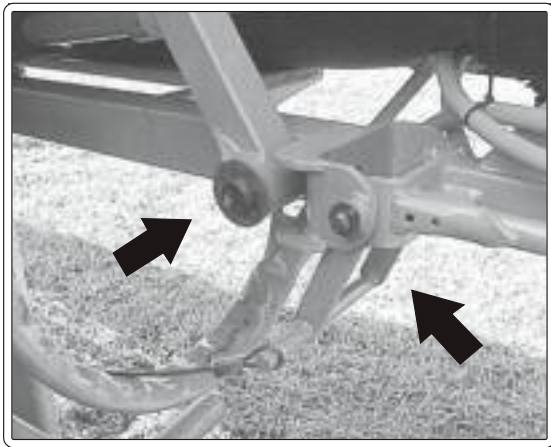
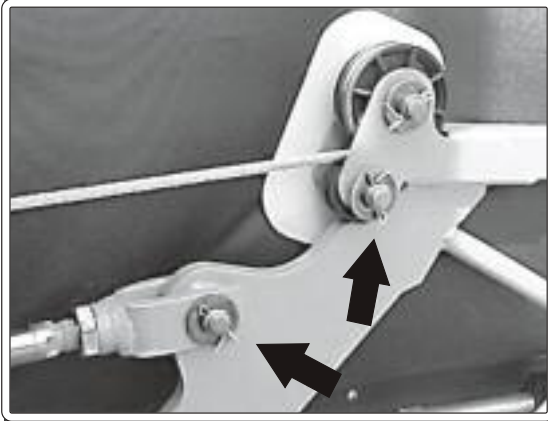

PTO SHAFT

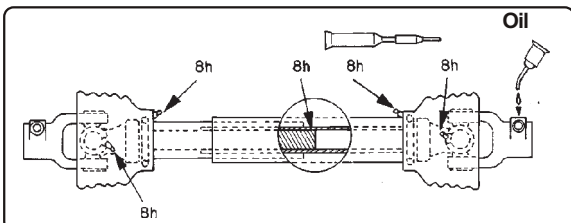

MAINTENANCE

HYDRAULIC OIL RESERVOIR

The hydraulic oil reservoir is the fan housing itself. The fan housing is made of aluminum, a material that is more sensitive to impacts than the steel. Therefore, you should take extreme care when servicing close to this area.

The capacity of the hydraulic oil reservoir is 45 liters.

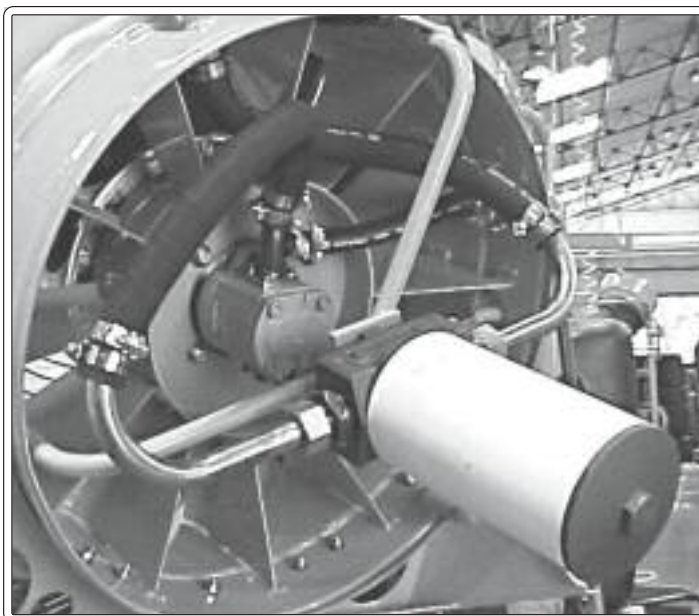
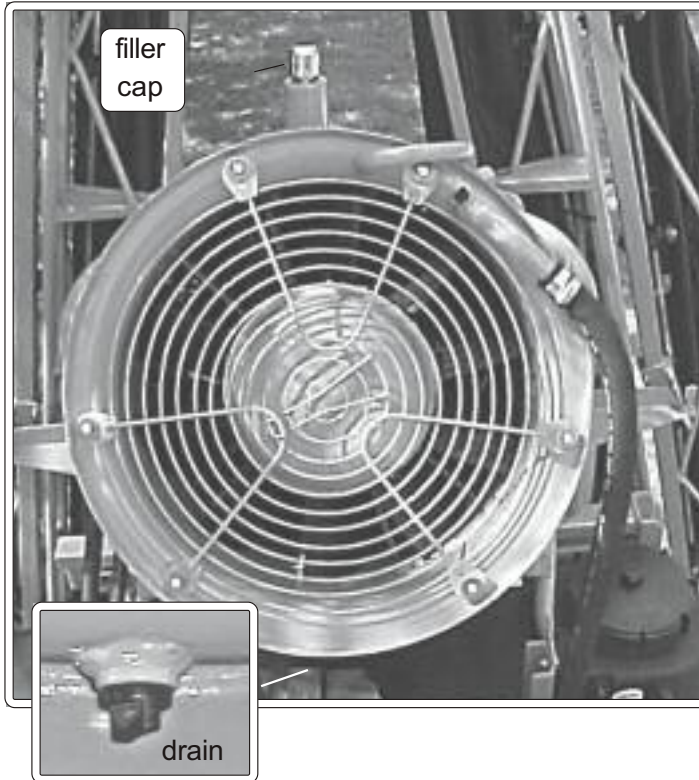

FILTERING ELEMENT

The filtering element should be replaced after the first 50 working hours and the further replacements should be done every 250 working hours, or in case of oil contamination. To replace the filtering element, you must drain all the oil of the reservoir.

NOTE:

The excessive oil contamination causes oil overheating .

FILTERING ELEMENT:

- BRAND: HDA
- SPECIFICATION: FR24-10-12N

MAINTENANCE

CONVENTIONAL PTO SHAFT

WARNING: ONLY OPERATE WITH PTO SHAFT EQUIPPED WITH SAFETY GUARD. ALL KIND OF MAINTENANCE ON THE PTO SHAFT MUST BE DONE WITH THE USE OF APPROPRIATE PROTECTIVE CLOTHING, SUCH AS: GLOVES, BOOTS, GOGGLES, ETC.

01-CONNECTING

- Check the PTO shaft length.
- Adjust the length by cutting the tubes and protection guards proportionately.

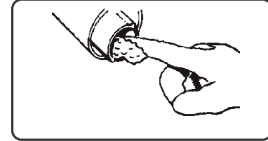
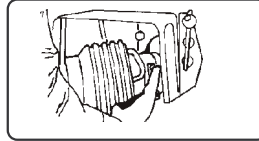

Note: File and remove all burrs.

- Lubricate the male and female tubes.
- Connect the PTO shaft and install the safety chain.

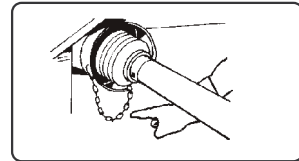
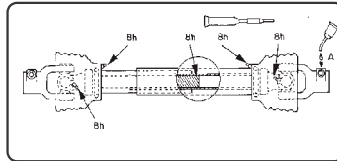

Note: Leave some slack on the chain considering angular movements.

- Disengage the PTO when making sharp turns.

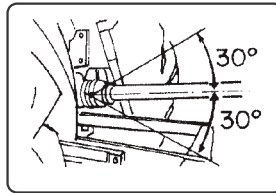

ATTENTION
ONLY OPERATE WITH
PTO SHAFT EQUIPPED
WITH PROTECTION
GUARDS.

02-SERVICING

a) DISASSEMBLING

- 1- Remove the lock screw.
- 2- Turn the guard cone until the indicated position.
- 3- Pull the guard cone.
- 4- Remove the sliding ring.

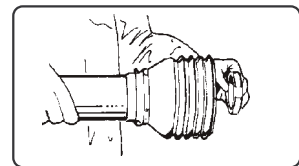
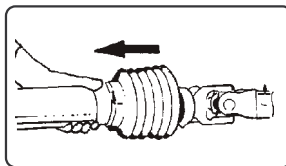
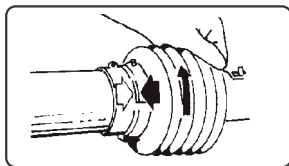
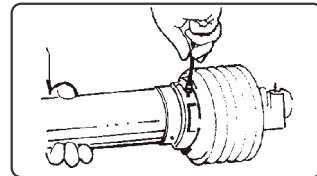

b) ASSEMBLING

- 5- Clean and lubricate the male and female tubes.
- 6- Install the sliding ring into the fitting with the grooves pointing toward the tube.

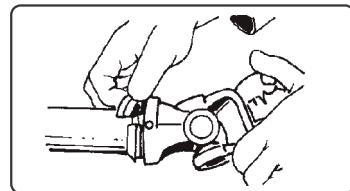
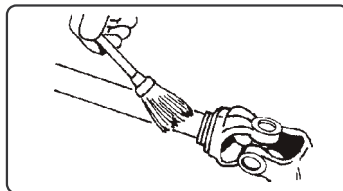

- 7- Install the protection guards.

- 8- Turn the guard cone until the indicated position.

- 9- Install the lock screw.

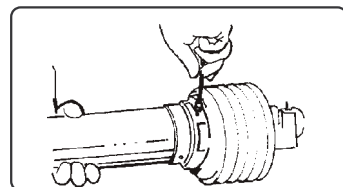
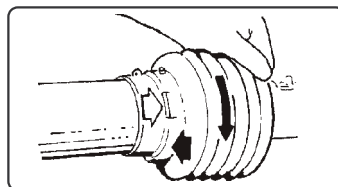
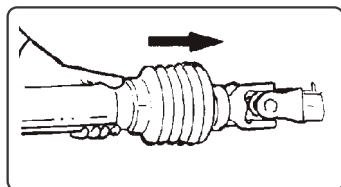

MAINTENANCE

WINTER STORAGE

ATTENTION: In areas where temperatures drop to 0° or less, the water accumulated in the pump can freeze and cause serious damage.

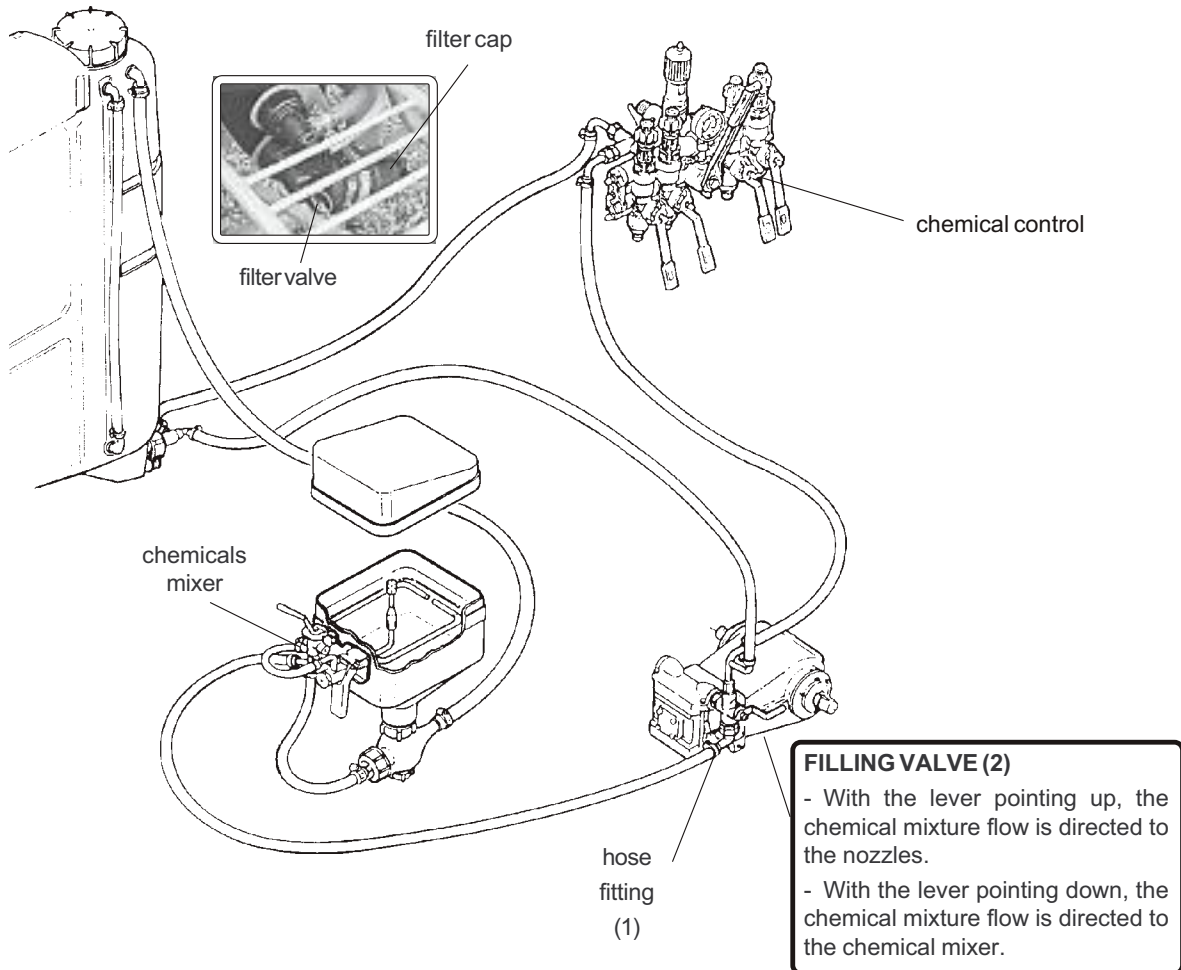

PROCEDURES

- Empty the tank completely, removing the tank lid and opening the filter valve.
 - Remove the hose fitting (1) from the filling valve (2). Set the filling valve lever to point down.
 - Run the sprayer for about 30 seconds at half speed.
- NOTE: To avoid damage to components do not run the pump over the recommended time.
- Then, set the filling valve lever back to the working position (to turn on the flow to nozzles).
 - Repeat this operation at the end of each working day during winter time to avoid problems in future sprayer applications.

MAINTENANCE

TROUBLE-SHOOTING

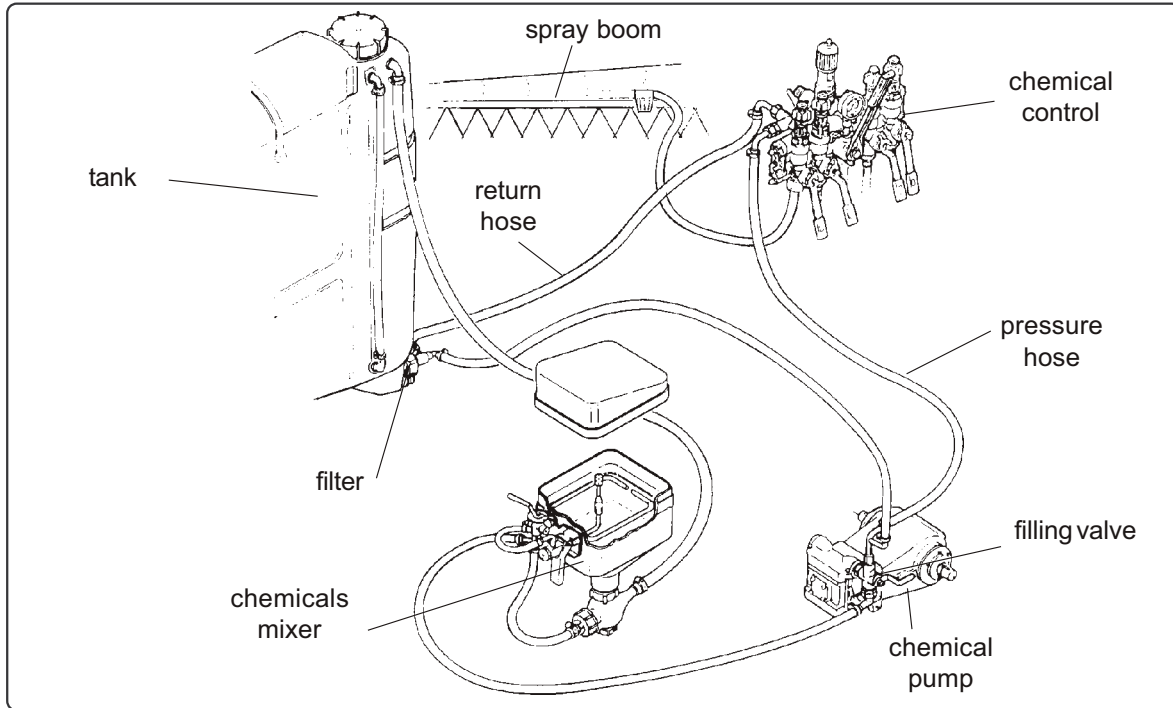

PROBLEMS - CAUSES - CORRECTIONS

Whenever Jacto sprayers equipped with piston pumps present problems, try to classify them in one of the following four groups:

a) LACK OF SUCTION AND PUMPING CAPACITY

No liquid flow through the nozzles.
No return to the tank;
Pressure gauge does not indicate pressure.

b) PRESSURE DEFICIENCY (PARTIAL LACK OF PRESSURE)

Desired pressure is not attained.
Specified nozzle spraying angle is not attained.
Pressure gauge shows lower pressure.

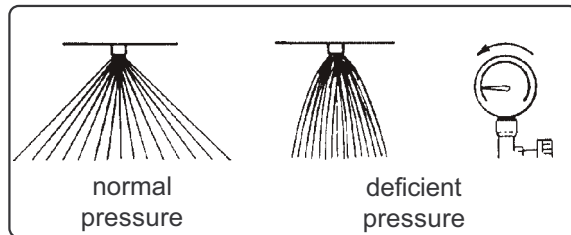

c) PRESSURE OSCILLATION

The pressure gauge needle oscillates;
The nozzle spraying angle oscillates.

d) INTERMITTENT PRESSURE

The pressure gauge needle vibrates with intensity.
The pressure hoses vibrate with intensity.
The nozzles spraying angle varies.

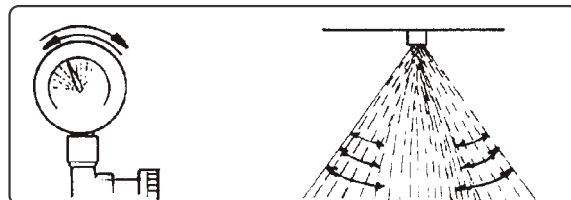
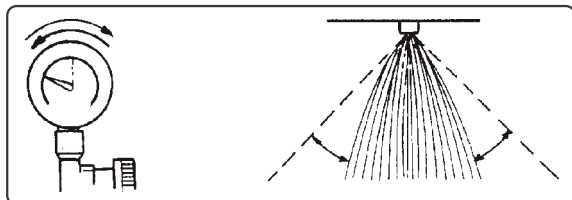

MAINTENANCE

TROUBLE-SHOOTING

a - LACK OF SUCTION AND PUMPING CAPACITY

PROBABLE CAUSES	SOLUTIONS
1- PTO not turning.	The sprayer should be run with 540 rpm at PTO. Check visually whether the pump is being run.
2- Lack of water in the tank.	To run the hydraulic system, it is necessary to contain a minimum quantity of liquid, otherwise there will be no pressure.
3- Filter shut off valve closed.	When the pump runs, liquid will pass through the valve even in the closed position, however it will be insufficient. Open it.
4- Dirty filter.	Impurities in the filter prevent a free liquid flow. Clean the filter whenever filling the tank, or with more frequency depending on the quality of the water and the type of product applied.
5- Obstruction in the intake hoses.	Check whether the hose connecting the filter to the pump is twisted. Check whether there is any obstruction in the hoses from tank to filter. Fill up the tank with water, open the valve and verify if it flows freely.
6- Air in the system.	Check the filter packing ring. The filter should not leak.
7- Insufficient pump suction.	Remove the cover of the suction valves. Check the condition of the valves and replace them if necessary.

b - PRESSURE DEFICIENCY

PROBABLE CAUSES	SOLUTIONS						
1- Low PTO rpm.	The proper PTO rotation is 540 rpm.						
2- Filter shut off valve closed.	When the pumps runs, liquid will pass through the valve even in the closed position, however flow will be insufficient.						
3- Filter partially obstructed.	The filter should be clean to allow free liquid flow.						
4- Intake hose partially obstructed.	A deficient pump will cause depressurization. Check whether the hose connecting the filter to the pump is twisted. Verify whether there is any obstruction in the hoses connecting the tank to the filter. Fill the tank with water, open the valve and observe if it flows freely.						
5- Air in the system.	Check the connections and the o'rings of the tank outlet and the pump inlet.						
6- Pressure regulator.	Check the valve and valve seat.						
7- Worn nozzles.	Check whether the nozzle flow is within the recommended guidelines. Replace the nozzles when the flow rate exceeds 10% of the specified. Use only nozzles recommended by the sprayer manufacturer.						
8- Pump with lower flow rate.	Disconnect the pressure hose from the control valve. Run the sprayer at 540 rpm. Collect water for one minute and measure. The volume collected should approximate this shown below for each pump model: <table style="width: 100%; border: none;"> <tr> <td style="width: 50%;">JP - 402 = 38 L/min</td> <td style="width: 50%;">JP - 100 = 100 L/min</td> </tr> <tr> <td>JP - 42 = 42 L/min</td> <td>JP - 150 = 150 L/min</td> </tr> <tr> <td>JP - 75 = 75 L/min</td> <td>JP - 300 = 300 L/min</td> </tr> </table>	JP - 402 = 38 L/min	JP - 100 = 100 L/min	JP - 42 = 42 L/min	JP - 150 = 150 L/min	JP - 75 = 75 L/min	JP - 300 = 300 L/min
JP - 402 = 38 L/min	JP - 100 = 100 L/min						
JP - 42 = 42 L/min	JP - 150 = 150 L/min						
JP - 75 = 75 L/min	JP - 300 = 300 L/min						

MAINTENANCE

c - PRESSURE OSCILLATION

PROBABLE CAUSES	SOLUTIONS
1- Loose belts.	Check belt tension and tighten if necessary.
2- Air in the intake system.	Check for damaged hoses, filter packing rings, etc., and repair if necessary.
3- Pressure regulator.	Check the regulator components and clean or replace them if necessary.

d - INTERMITENT PRESSURE

PROBABLE CAUSES	INDICATION AND CORRECTIONS
1- Valve closed	When the pump runs, liquid will pass through the valve even in closed position, however flow will be insufficient.
2- Pump valve deficiency	Valve with sealing deficiency or stuck due to impurities.
3- Pump head perforated internally.	Replace it.

GENERAL CARE

HANDLING AGRICULTURAL SPRAYERS AND CHEMICALS

We warn the owners and users that the UNREASONABLE USE of this sprayer and chemicals may cause damage to people, properties, animals and environment.

Read carefully and understand thoroughly this manual and the recommendations of the chemicals manufacturers.

Follow strictly the instructions for proper use of this sprayer and chemicals to ensure more safety and efficiency when spraying your crops.

AFTER SPRAYING

ATTENTION: Avoid leaving chemical mixture residues in the tank. For the last pass, prepare the quantity of chemical mixture enough to spray the remaining of the crop.

- Empty completely the tank and wash thoroughly the sprayer in a proper decontamination place.
- Wash the inside and outside of the sprayer with clean water and detergent.
- Disassemble and clean each nozzle assembly with fine brush, water jet or compressed air.
- Dry, lubricate and store the sprayer in a dry and covered place.
- Repaint the damaged metallic parts to prevent corrosion.
- Spray the metallic parts with lubricating oil to prevent corrosion.
- Take off the individual protective clothing and wash it separately from other clothes.

DANGER

SAFETY OBSERVATION

**OPERATING THIS SPRAYER WITHOUT FOLLOWING THE INSTRUCTIONS
MAY RESULT IN SERIOUS INJURY OR DEATH.**

STATEMENT OF LIMITED WARRANTY

MÁQUINAS AGRÍCOLAS JACTO S.A. warrants the equipment described herein and agrees to repair or replace parts and components which, under normal operation and wear, following the technical recommendations, show DEFECTS IN MATERIAL OR WORKMANSHIP.

WARRANTY PERIOD:

- One (1) year from the purchase date by the original retail purchaser.

WARRANTY APPLICATION:

Jacto or its authorized representative shall honor this warranty, if any part or component shows confirmed defect in workmanship.

IT SHALL BE UNDERSTOOD THAT THE REPLACEMENT OF ASSEMBLIES SUCH AS PUMPS, CONTROL VALVES, ENGINES, TRANSMISSIONS, HYDRAULIC PISTONS AND SIMILAR ONES SHALL ONLY BE PERFORMED IN CASE THAT THE DEFECT CANNOT BE REPAIRED BY REPLACING PARTS AND/OR COMPONENTS, NEW OR RECONDITIONED, ACCORDING TO RULES OR AUTHORIZED REPRESENTATIVE.

THIS WARRANTY IS NULL AND VOID IF:

- Equipment is not used in accordance with the INSTRUCTION MANUAL, overwork or accidents.
- Improper preventive maintenance or performed by unauthorized people.
- Modification of the equipment in any way from the original design.
- Change, damage, or loss of the product identification plate.
- Utilization of parts and components not supplied by JACTO.

PRODUCT REGISTRATION CARD MUST BE COMPLETED BY THE ORIGINAL RETAIL PURCHASER, AND RETURNED TO JACTO DEALER WITHIN 30 DAYS OF PURCHASE DATE.

WARRANTY EXCLUSIONS:

- Parts considered as normal maintenance such as: filtering elements, belts, hoses, nozzles, pistons, pressure gauges, as well as usual maintenance, adjustments, retightening, lubrication and painting.
- Parts which show wear or tear due to use, UNLESS THEY SHOW DEFECTS IN WORKMANSHIP, ASSEMBLY OR MATERIAL.
- Hydraulic, lubricating oils and grease.
- Injuries of personal or material nature to the user, owner, or third parties.
- Additional charges resulting from paralyzation and repair of the equipment.
- Freight charges, pick up and delivery charges.
- Damages of any nature resulting from action of gases or liquids used in the equipment.

GENERAL INFORMATION:

- Defective parts replaced under warranty period shall be property of JACTO.
- Eventual delays in performing services do not confer the owner the right to indemnity or to extension of the warranty period.
- JACTO reserves the right to change its products or to interrupt manufacturing the equipment.
- THIS LIMITED WARRANTY shall be understood by its expressed terms, and no one in anyway subject to JACTO shall be authorized to modify or amplify the conditions prescribed herein.
- In case of warranty claim, contact the authorized dealer supplying all information required for prompt service. Do not forget the identification of the equipment, total hours of work, and the noticed defect.

FOR THIS WARRANTY TO BECOME EFFECTIVE THE PRODUCT REGISTRATION CARD FOUND IN THE INSTRUCTION MANUAL MUST BE FILLED IN AND RETURNED TO YOUR JACTO DEALER. THIS CARD MUST BE SIGNED BY THE ORIGINAL RETAIL PURCHASER, INDICATING THAT HE HAS READ AND UNDERSTOOD ALL SAFETY AND OPERATIONAL INSTRUCTIONS IN THE MANUAL, FURTHER THE RETAILING DEALER HAS EXPLAINED TO THE ORIGINAL RETAIL PURCHASER ALL SAFETY INSTRUCTIONS. IN NO CASE WILL WARRANTY BE SUPPLIED UNTIL THIS CARD, PROPERLY COMPLETED AND SIGNED, IS ON FILE WITH JACTO RETAILING DEALER.



PRODUCT REGISTRATION CARD

INVOICE NUMBER: _____ DATE: ____ / ____ / ____
RETAILING DEALER: _____
PHONE: _____ CITY: _____ STATE: _____
MACHINE: _____ MODEL: _____
SERIES: _____ MACHINE No.: _____ PUMP No.: _____
ORIGINAL RETAIL PURCHASER: _____
ADDRESS: _____ PHONE: _____
CITY: _____ STATE: _____
PURCHASE DATE BY THE ORIGINAL RETAIL PURCHASER: ____ / ____ / ____
THE WARRANTY IS IN FORCE AS OF THIS DATE: ____ / ____ / ____
RETAIL PURCHASER SIGNATURE: _____

Original retail purchaser's copy



PRODUCT REGISTRATION CARD

INVOICE NUMBER: _____ DATE: ____ / ____ / ____
RETAILING DEALER: _____
PHONE: _____ CITY: _____ STATE: _____
MACHINE: _____ MODEL: _____
SERIES: _____ MACHINE No.: _____ PUMP No.: _____
ORIGINAL RETAIL PURCHASER: _____
ADDRESS: _____ PHONE: _____
CITY: _____ STATE: _____
PURCHASE DATE BY THE ORIGINAL RETAIL PURCHASER: ____ / ____ / ____
THE WARRANTY IS IN FORCE AS OF THIS DATE: ____ / ____ / ____
RETAIL PURCHASER SIGNATURE: _____

**URGENT
RESPOND WITHIN 30 DAYS
FIRST CLASS POSTAGE REQUIRED**