

J-2600

English version - MI_USA-0326

EDITION - 12/2007

CODE - 928085

Operator's Manual



JACTO INC.

9650 SW Herman Road
Tualatin, Oregon 97062

Tel.: (503) 885-8723

Fax: (800) 511-3671

Toll Free: (800) 522-8610

E-mail: info@jacto.com

Home page: www.jacto.com

INTRODUCTION

The agrochemicals application is necessary to achieve higher and economical production.

However, as it is a work that can bring risks to the human being, environment and crops, Jacto has always been concerned with the proper use of its spraying machineries in an efficient and safe way.

Therefore, read carefully and understand thoroughly this manual before operating this sprayer and keep it always at hand when handling this sprayer for quick consult in case you are not quite sure of some operation or adjustment.

Should your doubt persist, please contact your Jacto dealer.

MÁQUINAS AGRÍCOLAS JACTO S.A. CONTRIBUTING TO THE AGRICULTURE DEVELOPMENT.

IDENTIFICATION PLATE

Your sprayer has a plate showing its model and serial number.

This information is very important so that Jacto can keep records of eventual modifications made on the material used and on its construction characteristics.

In requesting replacement parts or maintenance, always specify the model and serial number of your sprayer for prompt and efficient service.



Jacto is trademark registered by Máquinas Agrícolas Jacto S.A.

**JACTO RESERVES THE RIGHT TO CHANGE SPECIFICATIONS AND DESIGN
WITHOUT PRIOR NOTICE.**

TABLE OF CONTENTS

SAFETY INSTRUCTIONS	
- Handling agricultural sprayers	05
- Handling chemicals	06
- Safety decals	07
- Safety measures	10
PRESENTATION OF SPRAYER	
- J -2600	11
- Fan features	12
MAIN COMPONENTS OF SPRAYER	
-Suction filter	13
-Pump	13
- Air duct	13
-Pressure regulator	14
- Nozzles	14
- Fan	15
- Mechanical Agitator	15
- Conventional PTO shaft	15
- Wide-angle CV PTO shaft (OPTIONAL)	15
- Gearbox	16
- Spray gun (OPTIONAL)	16
OPERATIONAL PROCEDURES	17
CHOOSING THE TRACTOR	18
SETTING UP THE TRACTOR	19
CONNECTING THE PTO	
- Conventional PTO Shaft (without CV joint)	20
- Wide-angle CV PTO shaft (with CV joint)	21
OPERATION AND ADJUSTMENTS	
- Duct hydraulic system	22
- Spray application technology	23
- Chemical control	24
- Nozzles flow rate	25
- Calibrating the sprayer	28
- Diluting the chemicals	29
- Chemical container rinse	30
- Procedures	30
- Washingth chemical container	31
- Flow rate table	32
- Selecting the spray swath	32
- Tractor's path and duct inclination	33
- Adjusting the auxiliary ducts	33
MAINTENANCE	
- Guidelines	34
- Components	34
- Components lubrication	35
- Lubrication table	36
- Lubrication points	36
- Track width and ground clearance	37
- Track width adjustment - Safety instructions	38
- Conventional PTO shaft	39
- Wide-angle CV PTO shaft (OPTIONAL)	40
- Belts	42
- Winter storage	43
- Trouble-shooting	44
GENERAL CARE	
- Handling agricultural sprayers and chemicals	47
- After spraying	47
STATEMENT OF LIMITED WARRANTY	48

SAFETY INSTRUCTIONS

HANDLING AGRICULTURAL SPRAYERS

OWNER / OPERATOR:

This sprayer was carefully designed and built so as to give you the maximum production, saving, easy operation and safety.

Therefore, you or anyone else who is going to operate, maintain and work around this sprayer must read and understand this manual thoroughly in order to be familiar with all the operating and maintenance procedures and safety information related to this sprayer. All accidents can be prevented if all the safety instructions are correctly followed.

Moreover, always keep this manual at hand for quick review in case of doubt.



ATTENTION
FAILURE TO FOLLOW THE SAFETY
INSTRUCTIONS PROPERLY WILL RISK YOUR
OWN LIFE AS WELL AS THE LIFE OF PEOPLE
WORKING AND LIVING AROUND YOU.

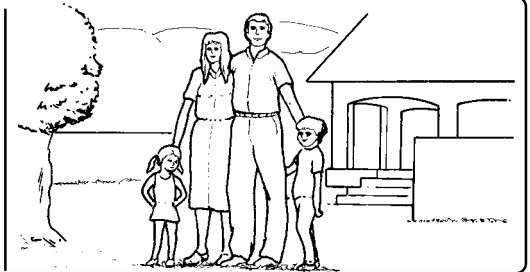

This safety alert symbol identifies important safety messages. When you see it, be alert to any possibility of personal injury or death. Keep all the decals on the sprayer and replace them if missing or illegible.

- Before operating this sprayer, read carefully and understand thoroughly this manual.
- Do not allow untrained people to operate this sprayer because this can cause serious injuries or fatal accidents.
- Do not modify this sprayer in any way because this can impair the function and risk your safety.
- Keep away children, aged people and animals while operating, servicing this sprayer and even when the sprayer is stored.
- In the delivery of your sprayer, have your Jacto dealer instruct you on the assembly, operation, maintenance and warranty in detail.
- Keep hands, feet and clothing away from moving parts.
- Never use loose clothing or mittens while working around the sprayer.
- Do not travel at high speeds.
- **Always stop tractor engine, disengage the PTO and wait for all moving parts to stop before servicing, adjusting or repairing the sprayer.**

ATTENTION: Do not touch PTO shafts, belts, fans or any other moving part while the sprayer is running.

- Only unhitch the sprayer on firm and level ground.
- Keep your sprayer in thorough repair.
- **ATTENTION:** When using track width set at 4.23 ft and ground clearance of 1.21 ft, the risks of turning over the sprayers are higher on irregular ground. See recommendations in the section MAINTENANCE - ADJUSTING TRACK WIDTH.

SAFETY INSTRUCTIONS

HANDLING CHEMICALS

Chemical products are classified in four categories of toxicity. According to their toxicity level, there is a special recommendation of appropriate protective equipment.

As your safety concerns first, we list below all the protective equipment recommended for handling chemical products of the category 1 which includes high toxicity level chemicals.

This way, all the possibilities of serious illness and death are eliminated.

Obligatory individual protective equipment for handling and spraying chemicals:

- Long-sleeved working clothes
- Impermeable apron or coverall
- Impermeable gloves
- Impermeable wide-brimmed hat
- Boots
- Special protective masks equipped with appropriate filters for each type of product

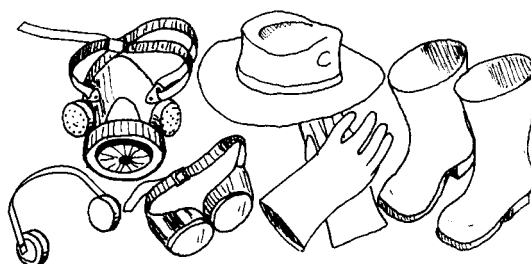

CHEMICAL PRODUCTS CLASSIFICATION

	TOXICITY LEVEL		LABEL COLOR ON CHEMICALS CONTAINER
	I	HIGH	RED
	II	MODERATE	YELLOW
	III	LOW	BLUE
	IV	LIGHT	GREEN

DIRECTIONS

- Read and follow all instructions on the chemicals manufacturer's label.
- Keep the chemical products closed and in a dry and ventilated place.
- Use the chemical products in agriculture only.
- Keep away children, untrained people and animals.
- Handle the chemicals following recommendations of a technician.
- Always handle chemicals in a ventilated place and equipped with individual protective equipment.
- Use the application rate as per instructions on the labels.
- Do not make spray applications in the wind or hot weather.
- Do not drink, eat or smoke while spraying or handling chemicals.
- Keep children, untrained people and animals away from the application areas.
- Never blow through nozzles strainers, valves or pipelines by mouth.
- Do not store or transport chemical products together with food, medicines, people, animals.
- Make sure rivers, lakes, etc. will not be contaminated when washing out the sprayer.
- After spraying, take off all protective clothing and take a shower.
- In case of intoxication, go see a doctor immediately and show him the chemical products label.
- Never medicine an unconscious person through mouth.
- **Do not re-use the chemical products containers for other purposes. Consult an agronomist on how to discard empty containers of chemical products.**

SAFETY INSTRUCTIONS

DECALS

Safety decals are placed on the equipment to reduce the risk of damages or accidents to the operator or to the equipment during the use.

Before operating the equipment, identify and understand the mean of all decals, through this page.

Keep them in good repair, clean and legible. Replade them immediately in case of damage by ordering them through the part numbers specified below.



ATTENTION: Lubrication point

P/N: 276220



ATTENTION: Drain point.

P/N: 389387



ATTENTION: Area where the jack must be placed to lift the equipment.

P/N: 276238



ATTENTION: Lubrication point with oil.

P/N: 395061



ATTENTION: Read the operator's manual before operating the sprayer.

P/N: 379230



ATTENTION: Read the operator's manual before operating the sprayer.

P/N: 379248



ATTENTION: Risk of serious injuries. Keep all protection devices in its places.

P/N: 379065



ATTENTION: Do not get into the main tank of the sprayer.

P/N: 380014

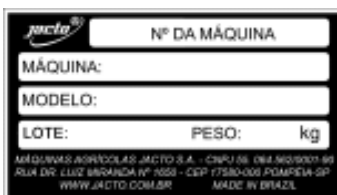

Identification plate

P/N: 047035



Final test of the equipment.

P/N: 013169

SAFETY INSTRUCTIONS



ATTENTION: Maximum speed allowed for the machine is 18.5 mph.

P/N: 379214



ATTENTION: Obligatory use of protective clothing.

P/N: 379131



ATTENTION: Risk of serious injuries. Do not make any operation on the PTO shaft if the PTO is engaged.

P/N: 379008



ATTENTION: This machine is not allowed in highways.

P/N: 379222



ATTENTION: Hydraulic oil level indicator.

P/N: 379107



ATTENTION: Obligatory use of protective mask.

P/N: 379115



ATTENTION: Never operate the valve of the chemical rinse nozzle if the container is not duly positioned over the rinse nozzle.

P/N: 169128



ATTENTION: Obligatory use of hearing protector.

P/N: 379123



Instructions to connect the PTO shaft

P/N: 428631



Instructions to unlock the fan.

P/N: 018705

SAFETY INSTRUCTIONS



P/N: 219717

Instructions to adjust draw bar.

		cm ²	kgf/cm ²
Arbex 200	175/70 R13	23	2,25
Arbex 300	7,50-15	26	1,85
Arbex 1000	7,50-15	30	2,00
Arbex 1500/735	7,50-15	30	2,00
Arbex 1500/850	110-15	64	3,10
Arbex 2000/735	110-15	64	3,10
Arbex 2000/850	110-15	64	3,10
Arbex 2000/950	7,50-15	30	2,00
Arbex 4000/850	11,5-15	64	3,10
Arbex 4000/950	14,0-20	31	2,30
Jacto 3000	110-15	64	3,10
Jacto 3000	7,50-15	30	2,00
Jacto 3000	12,00-20	26	1,82
Card 3P e 5P	7,50-15	30	2,00

P/N: 391631

ATTENTION: Tire pressure table.

	Kgf.m	N.m	ft.lb
	39-45	383 442	282 326
	10,3 11,75	100 115	75-85
	18 23,5	176 230	130 169

P/N: 379164

ATTENTION: Nut torque table.



Decal "JACTO"

P/N: 388272



Designer sticker left.

P/N: 280735



Designer sticker right.

P/N: 280743



Decal "J-2600 cannon"

P/N: 262758



Decal "Jacto-cannon sprayer J-2600"

P/N: 178699

SAFETY INSTRUCTIONS



ATTENTION: THIS SAFETY ALERT SYMBOL IDENTIFIES IMPORTANT SAFETY MESSAGES. WHEN YOU SEE IT, BE ALERT TO ANY POSSIBILITY OF PERSONAL INJURY OR DEATH.

SAFETY MEASURES

- Keep all the protectors on their proper places.
- Remove the controls installed on the tractor before disconnecting the sprayer.
- Do not operate the pump without liquid.
- Clean and lubricate regularly the male and female parts of the PTO shaft to reduce the friction between them.
- Lubricate daily the grooved shaft of the tractor's PTO.
- Keep the hands, feet and clothes away from PTO shafts and any type of transmission, once they can cause serious injuries, even death.
- Never operate the sprayer if the PTO shaft, the sprayer and the tractor's PTO protectors are not in their proper place.
- Do not exceed 580 rpm at the PTO.
- The PTO shaft protector must always remain in good repair and fastened by the belts. The PTO shaft must work freely in its interior.
- The PTO shaft coupling ends must be locked on the tractor's PTO and sprayer's shaft.
- Make sure the drawbar and the sprayer end are properly engaged .
- Follow these recommendations strictly in order to avoid injuries or death .
- Check and change the worn and broken parts. Check if all protectors are in their places before operating the sprayer.
- Make sure that no one is close to the machine before running the engine.
- Stop the engine before leaving the operator's position to adjust, clean or lubricate, save other recommendation indicated on the operator's manual.
- Stop the machine and all moving parts before adjusting, maintenance or when there are people close to the equipment.
- Do not go up on the sprayer when it is in motion.

PRESENTATION OF SPRAYER



TECHNICAL SPECIFICATIONS

Model	J - 2600
Length (in)	170
Width (in)	
- Minimum	62
- Maximum	75
Height (in)	
- Minimum	102
- Maximum	108
Weight (lb)	1,918
Tank	
- Capacity (gallons)	550
- Material	Polyethylene
Filter	
- Model	FVS-200
- Mesh	24/40
Pump	
- Model	JP-50 / JP-100
- Capacity (gpm) at 540 rpm	13 / 26
- Maximum pressure (kgf/cm ² - psi)	35 - 500
- Power consumption (HP) at 400 psi	3.5 / 6.9
Spray swath	
- Without wind	100 ft
Tires	
- Type	7.5 x 36
- Pressure (kgf/cm ² -psi)	3.9 - 55
Ground clearance (in)	
- Minimum	8
- Maximum	14
Track width (in)	
- Minimum	49
- Maximum	55
Agitator	Mechanical
Chemical control	MF-2000 2X2
Pressure gauge	with extended scale
Recommended maximum working speed (mph)	1.5 to 4
Total power consumption (HP)	26.7

PRESENTATION OF SPRAYER

FAN FEATURES

DESCRIPTION	J - 2600
Fan diameter (in)	23.6
Pulley diameter (in)	4.1
Rotation (rpm)	3030
Air volume (cfm)	5.445
Air speed (mph)	171

J - 2600 - OPTIONS

PUMP	MODEL	JP-100
FILLER UNIT	MODEL	QUICKFITTING
TIRE	MODEL	11L x 15
PTO SHAFT	MODEL	WIDE-ANGLE C.V

PRESENTATION OF SPRAYER

SUCTION FILTER

Located between the tank and pump, the suction filter is specifically designed to prevent dirt or impurities from reaching the pump.

It has a quick shut off valve which allows easy filter cleaning, filtering elements changing and/or pump maintenance. This valve should always remain open while the sprayer is running. If it remains closed, the mechanical seal of the pump can be damaged.

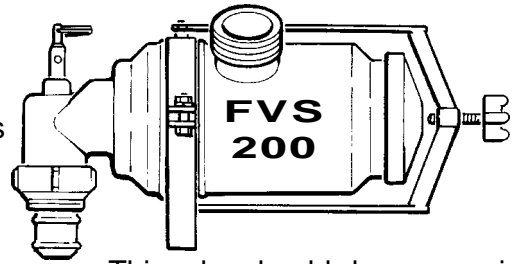

PUMP

The pumps mounted to Jacto sprayers have capacity ranging from 13 to 26 gallons per minute.

PUMP	FLOW RATE (gpm)	MAXIMUM WORKING PRESSURE	
		psi	kgf/cm ²
JP - 50	13	500	35
JP - 100	26	500	35

Their ceramic liners ensure greater resistance to abrasion and chemical action.

Moreover, the piston cup can be easily replaced by removing the head assembly in a quick and simple operation with no need to remove the pump.

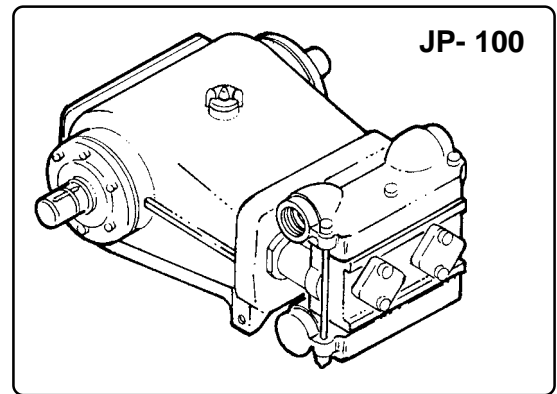
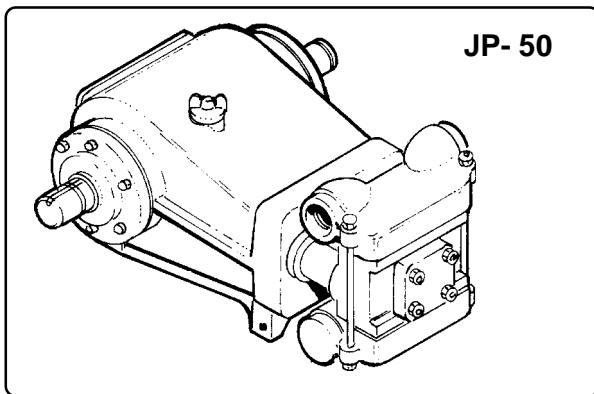

DUCT

The main duct on the J - 2600 can be adjusted both horizontally and vertically. It also has two auxiliary ducts to cover the area close to the tractor, thus improving the quality of spray applications.

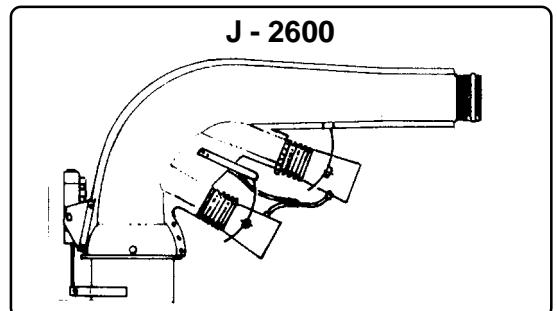

MAIN COMPONENTS OF SPRAYER

PRESSURE REGULATOR

The Masterflow 2000 2x2 pressure regulating control provides adjustments of up to 5.5 kgf/cm² (80 psi) on the side that controls the flow to the main and auxiliary ducts (cable operation) and 20.7 kgf/cm² (300 psi) on the side that controls the flow to the spray guns (lever operation).

The levers (1),(2) and (3) have different functions: lever (1) diverts the chemical flow to the ducts or spray guns; levers (2) distribute the chemical flow to the main and auxiliary ducts; and levers (3) distributes the chemical flow to the spray guns when in use.

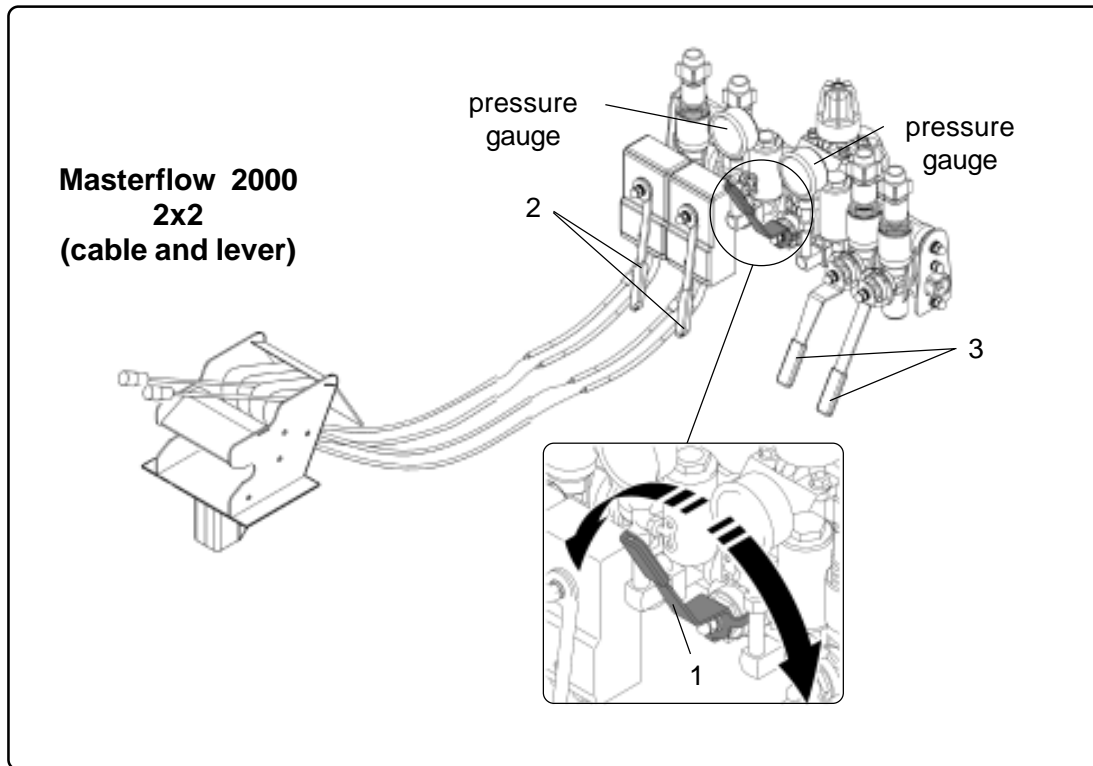

NOZZLES

- The job of the nozzles is to generate droplets and distribute them uniformly over the area being sprayed.
- Flow, size and distribution vary according to the air volume generated by the fan. Therefore, always work as directed in the operator's manual.

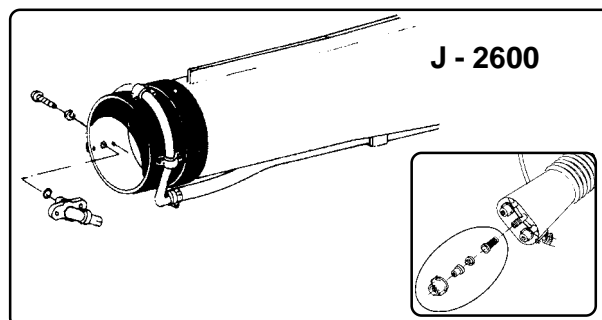

MAIN COMPONENTS OF SPRAYER

FAN LOCK

This device is specifically designed to lock the fan off in order to reduce power consumption when the use of fan is not required, that is, while filling the tank and agitating the chemical mixture before starting to spray. To lock the fan, pull the lock and give it a quarter turn. To unlock, pull the lock, give it a quarter turn and then push it again.

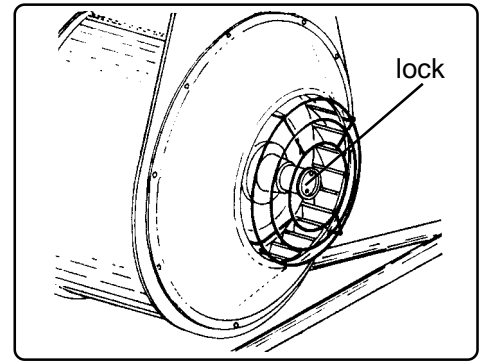

ATTENTION: For tractors with independent PTO, the following is recommended:

- Do not engage the PTO with the engine accelerated.
- With the engine idling, engage the PTO and gradually accelerate until reaching the recommended rpm.

MECHANICAL AGITATOR

This device provides a better homogenization to the chemical mixture, thus reducing clogging of nozzles and filters.

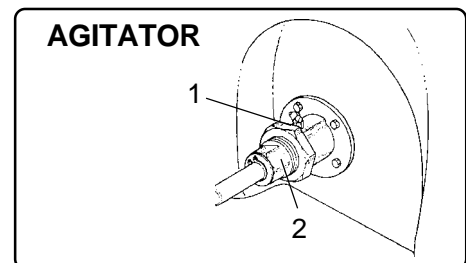

CONVENTIONAL PTO SHAFT

The sprayer's PTO shaft is equipped with plastic protection guards to prevent the operator and his clothes from touching the PTO shaft and avoid damage to the crops.

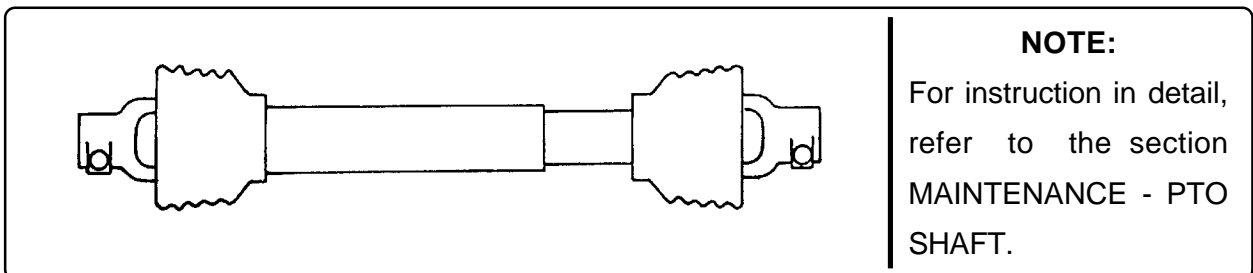

WIDE-ANGLE CV PTO SHAFT (OPTIONAL)

The wide-angle CV PTO shaft is a component whose advantage on the standard PTO shaft is in allowing the sprayer to make turns of up 75-degree angle with no need to disengage the PTO.

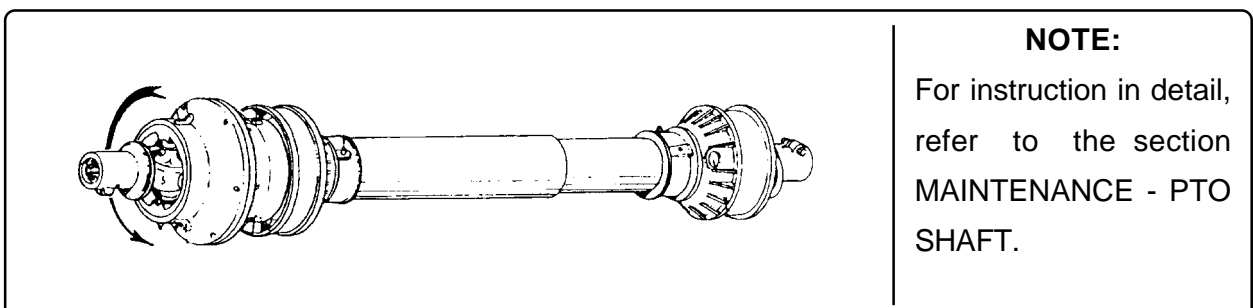

MAIN COMPONENTS OF SPRAYER

GEARBOX

Placed between the tank and the fan, the gearbox has the function of multiplying the PTO shaft rotation (540 rpm) for the fan.

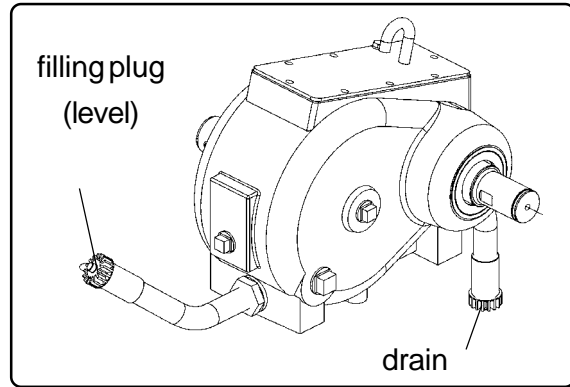

SPRAY GUN (OPTIONAL)

The spray gun is an accessory for localized spot spraying of tall trees which requires a high spraying volume.

It is possible to increase the gun flow rate from 1.32 to 11.88 gpm by replacing the spray discs.

STAINLESS STEEL SPRAY DISCS - SERIES D

The spray discs are recommended for localized spot spraying in fruit crops in general due to its long reach spray. They are made of stainless steel and have flow rates ranging from 1.32 to 11.88 gallons per minute.

These discs must be used with the Jacto spray gun, specially designed for this type of spray application.

SPRAY DISCS FLOW RATE TABLE - SERIES D

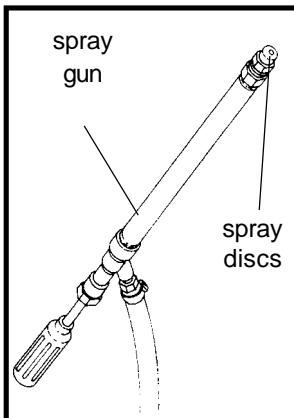

SPRAY DISC PART No.	SPRAY DISC MODEL	PRESSURE (psi)				
		100	150	200	300	400
SPRAY GUN FLOW RATE (GPM)						
202275	D - 5	1.32	1.58	1.85	2.11	2.50
202267	D - 6	1.81	2.24	2.64	3.17	3.57
202811	D - 7	2.47	2.88	3.30	3.90	4.50
202259	D - 8	3.39	3.96	4.50	5.28	6.24
622829	D - 9	3.75	4.66	5.47	6.71	7.76
114686	D - 10	4.89	5.81	6.74	7.92	9.42
622837	D - 11	5.54	6.54	7.75	9.77	11.88

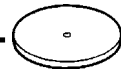

OPERATIONAL PROCEDURES

Stage	Procedure	J-2600
Spraying	Use individual protective clothing	X
	Do not work at high speeds	X
	Do not spray against the wind	X
	Do not travel with boom lifted or unlocked	X
	Take care with electricity supply cables	X
	Do not eat, drink or smoke while spraying	X
	After spraying, dispose of all protective clothing and take a shower	X
Receiving the sprayer	Strictly follow all information contained in this operator's manual	X
	Check if all components are intact	X
	Check the components of accessories box	X
	Require trained person to instruct about assembling, operating and servicing components and accessories	X
Using the sprayer for the first time	Check if the hitch pin is original	X
	Check if the hitch pins have cotter pins	X
	Check the overlaps of the PTO shaft	X
	Raise to the highest the tractor's hydraulic arms	X
	Check if the grease fittings are filled	X
	Check if the oil is on the level on the components	X
	Calibrate the tires	X
Retighten the tank nuts and lug nuts	X	
Whenever filling the tank	Clean the suction or line filters	X
	Clean nozzles and their strainers	X
Every day or every 10 hours	Clean nozzles, strainers and filters	X
	Check the grease fittings and joint pins	X
	Check the oil level on the pumps and gear box	X
	Wash the inside and outside of the sprayer	X
	Check for damage on the paint and repaint	X
	Check for oil leakage and stop it	X
	Store the sprayer in a dry, ventilated and indoor place	X
First 30 hours	Change for the first time the pump oil	X
	Retighten the bolts on the tank, axle and wheels	X
Every 100 hours	Change the oil of the pump and gearbox	X
	Tighten the belts	X
	Clean and check the pressure regulator components	X
	Clean the inside and outside of the sprayer, and paint the parts subject to corrosion with lubricating oil	X
Every 500 hours or annually	Service the pump	X
	Change hydraulic oil	X
	Change the oil of the gearbox	X
	Retighten the bolts of tank, wheels, axle, etc.	X
	Change the grease of the wheel hub	X
Every 1000 hours	Replace the belts of the equipment	X
Every 2000 hours	Replace the bearings of the drive transmission	X
	Replace the bearings of the driven transmission	X
	If necessary, replace the pressure gauge	X

CHOOSING THE TRACTOR

PROCEDURES

Different working conditions lead us to adopt the following criterion for choosing the tractor that will drive the J-2600 cannon sprayer.

- Check the sprayer weight on the identification plate.
- Check the tank capacity.
- Check in the specifications table the total power consumption of the sprayer at the PTO.

Example:

Sprayer weight = 2,006.20 lb

Tank capacity = 550 gallons

Total power consumption = 26.7 HP

CHOOSING THE TRACTOR CONSIDERING THE POWER CONSUMPTION AND THE LOAD TO BE TRANSPORTED

1st - POWER CONSUMPTION

The tractor should have power (HP) at least 90% higher than the power required to run the sprayer.

Ex.: Power required by the sprayer = 26.7 HP

Minimum tractor nominal power = 60 HP

2nd - LOAD TO BE TRANSPORTED

The tractor gross weight should be at least equal to the sprayer gross weight (sprayer net weight plus full tank weight).

Ex: Sprayer net weight = 2006.20 lb

Full tank weight = approximately 2,006.20 lb (550-gallons tank)

Sprayer gross weight = 6,415.44 lb

Tractor gross weight = 6,415.44 lb or more

ATTENTION

In this case the recommended tractor should have minimal nominal power of 26.7 HP and weigh at least gross 6,415.44 lb.

SETTING UP THE TRACTOR

- Adjusting the drawbar

Fit the drawbar pin into the proper hole (1 or 2) to vary the distance between the PTO shaft and the hitch point (see figure A).

Hole	Distance between the PTO shaft and the hitch point	Maximum (static) load in lift
1	13.7 in	1003 lb
2	9.8 in	1300 lb

NOTE:
For heavy load, the hole no. 2 is recommended (see figure A).

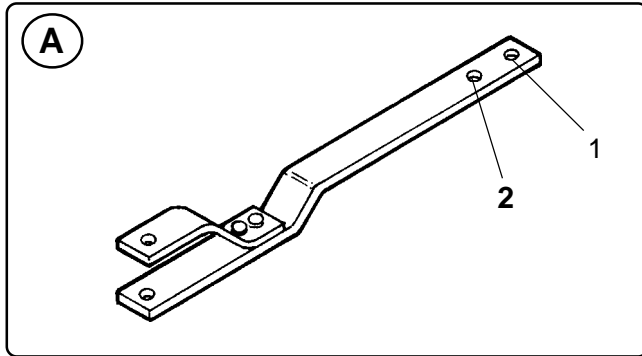

ATTENTION

The figures shown in above table were obtained on a 63 HP tractor.

For explanation in detail, please consult the operator's manual of your tractor.

- Adjusting the sprayer height and the tractor's drawbar

Set the tractor's drawbar so as to allow the sprayer to work on level after being hitched (see figure B).

Invert the drawbar to vary the height of the hitching point (see figure C).

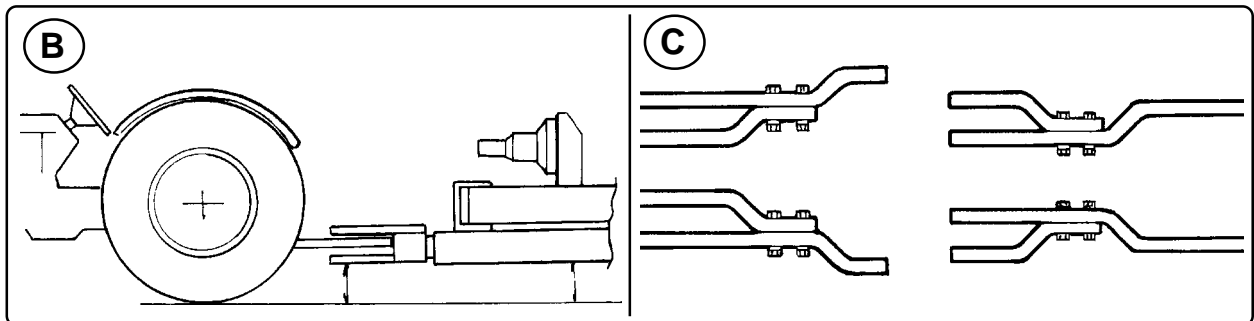

- Adjusting the sprayer's tongue

The sprayer's tongue can be adjusted from 29.5 to 37.4 in, as shown in the figure beside.

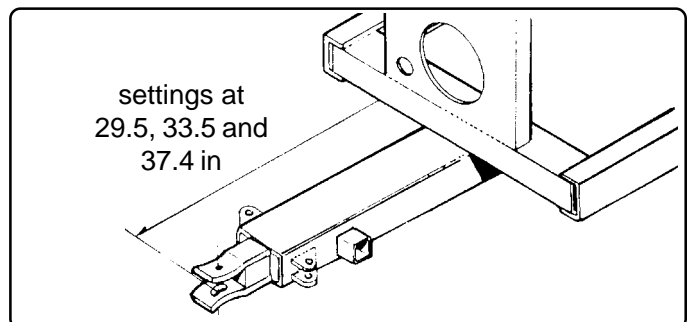

NOTE

In order to know what is the approximate weight (kg) put on the tractor drawbar when hitched to the J-2600 sprayer, just add the sprayer weight to the tank capacity and multiply the total by 0.12.

CONNECTING THE PTO

CONVENTIONAL PTO SHAFT (WITHOUT CV JOINT)

- ADJUST THE DRAWBAR LENGTH IN RELATION TO THE PTO AS SHOWN IN THE FIGURE BESIDE.

IDEAL CONNECTION

Distance A = B or as close as possible.

Ex.: If A = 15.7 in, then B should be somewhere between 13.7 and 17.7 in.

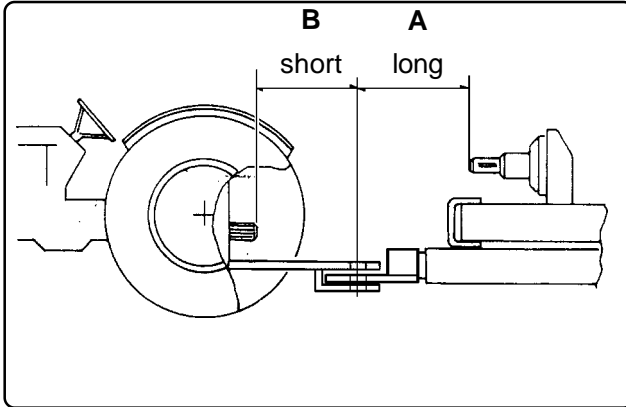

Hitch the sprayer to the tractor

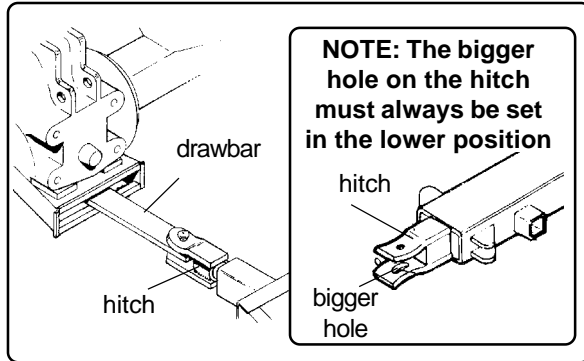

INSTALLING THE SAFETY CHAIN

- Install the safety chain as shown in the figure below and give heed to the following:

- Leave some slack on the chain so that it is not stretched when maneuvering.
- The chain holder (1) must be mounted as close to the hitch pin (2) as possible.

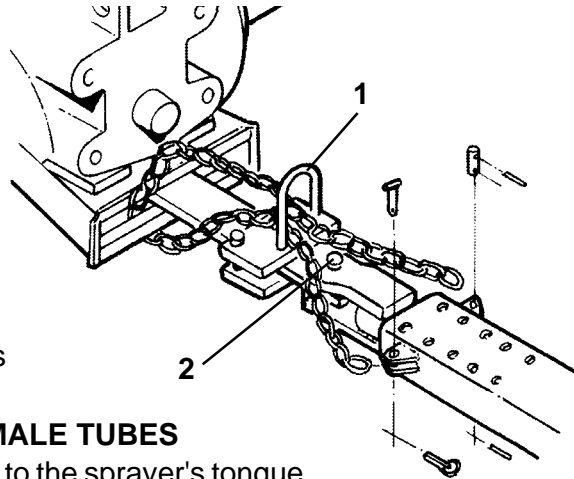

NOTE: Replace the safety chain if one or more links are damaged.

ADJUSTING THE PTO SHAFT MALE AND FEMALE TUBES

- Position the tractor until its rear tire gets close to the sprayer's tongue.
- Connect the PTO shaft.
- Adjust the male and female tubes lengths (recommended overlap: 2 in).

ATTENTION: When maneuvering, disengage the PTO and keep the tire from touching the sprayer's tongue, otherwise this will damage the sprayer's transmission.

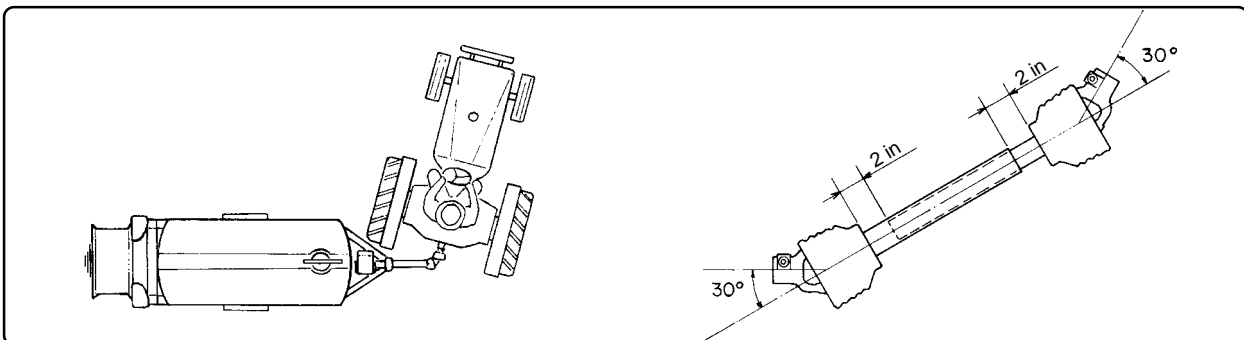

NOTE: Before cutting the PTO shaft tubes, check for all the possible adjustments of both tractor's drawbar and sprayer's tongue. Make sure the hitch pin is installed with cotter pin.

CONNECTING THE PTO

WIDE-ANGLE CV PTO SHAFT (WITH CV JOINT)

- Adjust the drawbar length in relation to the PTO as shown in the figure beside.

IDEAL CONNECTION

- The distance A must be as long as possible and the B as short as possible. This provides a wider angle to the CV joint.
- The ideal is to have A = two times B.

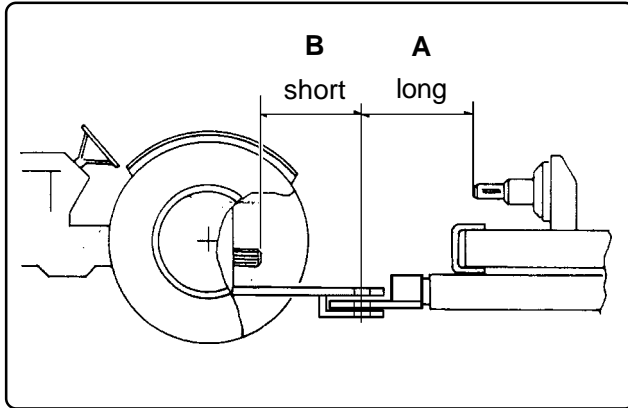

Hitch the sprayer to the tractor.

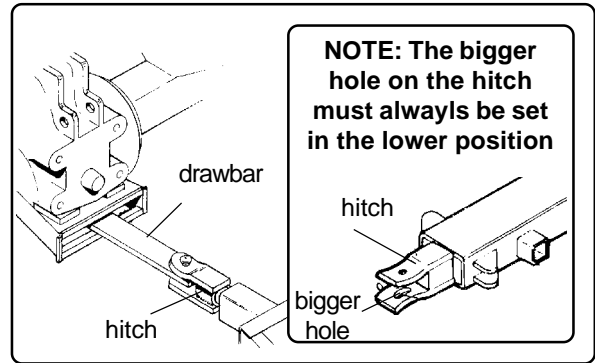

INSTALLING THE SAFETY CHAIN

- Install the safety chain as shown in the figure below and give heed to the following:
 - Leave some slack on the chain so that it is not stretched when maneuvering.
 - The chain holder (1) must be mounted as close to the hitch pin (2) as possible.

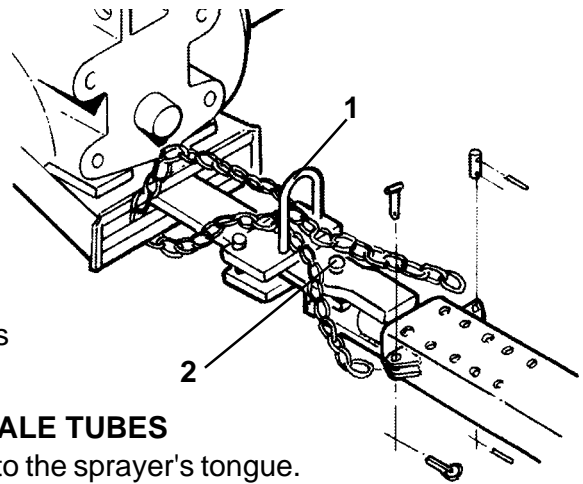

NOTE: Replace the safety chain if one or more links are damaged.

ADJUSTING THE PTO SHAFT MALE AND FEMALE TUBES

- Position the tractor until its rear tire gets close to the sprayer's tongue.
- Connect the PTO shaft.
- Adjust the male and female tubes lengths (recommended overlap: 2 in).

Attention: When maneuvering, disengage the PTO and keep the tire from touching the sprayer's tongue, other wise this will damage the sprayer's transmission.

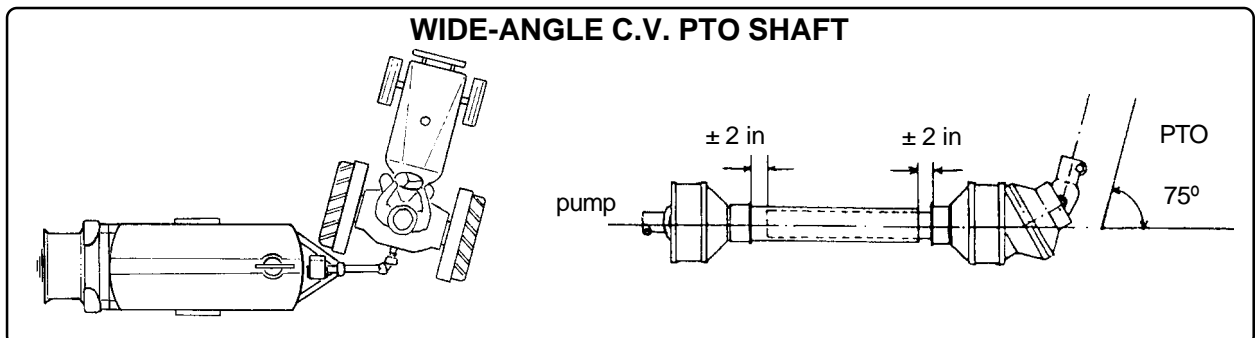

NOTE: Before cutting the PTO shaft tubes, check for all the possible adjustments of both tractor's drawbar and sprayer's tongue. Make sure the hitch pin is installed with cotter pin.

OPERATION AND ADJUSTMENTS

DUCT HYDRAULIC SYSTEM

J - 2600 has a duct hydraulic system that makes possible faster horizontal and vertical movement. This system operates with the tractor remote controls, therefore this sprayer will only operate on tractors equipped with two coupling points of the remote control.

NOTE: AS THIS SPRAYER WILL BE USING THE TRACTOR REMOTE CONTROL SYSTEM, ALWAYS READ THE TRACTOR INSTRUCTIONS MANUAL BEFORE ANY OPERATION.

Once you identify the remote control oil terminals on the tractor, proceed as follows:

- Connect the hoses with quick fitting connection, and make sure to fasten the two hoses of each cylinder to the same control block. The pair of hoses are separated by a plastic clamp.
- Then, identify the cylinder actuation levers in the tractor cabin.

ATTENTION: BEFORE CONNECTING OR DISCONNECTING THE HYDRAULIC HOSES, IT IS IMPORTANT TO RELIEVE THE SYSTEM PRESSURE BY TURNING OFF THE TRACTOR ENGINE AND MOVING THE REMOTE CONTROL LEVERS TO BOTH DIRECTIONS.

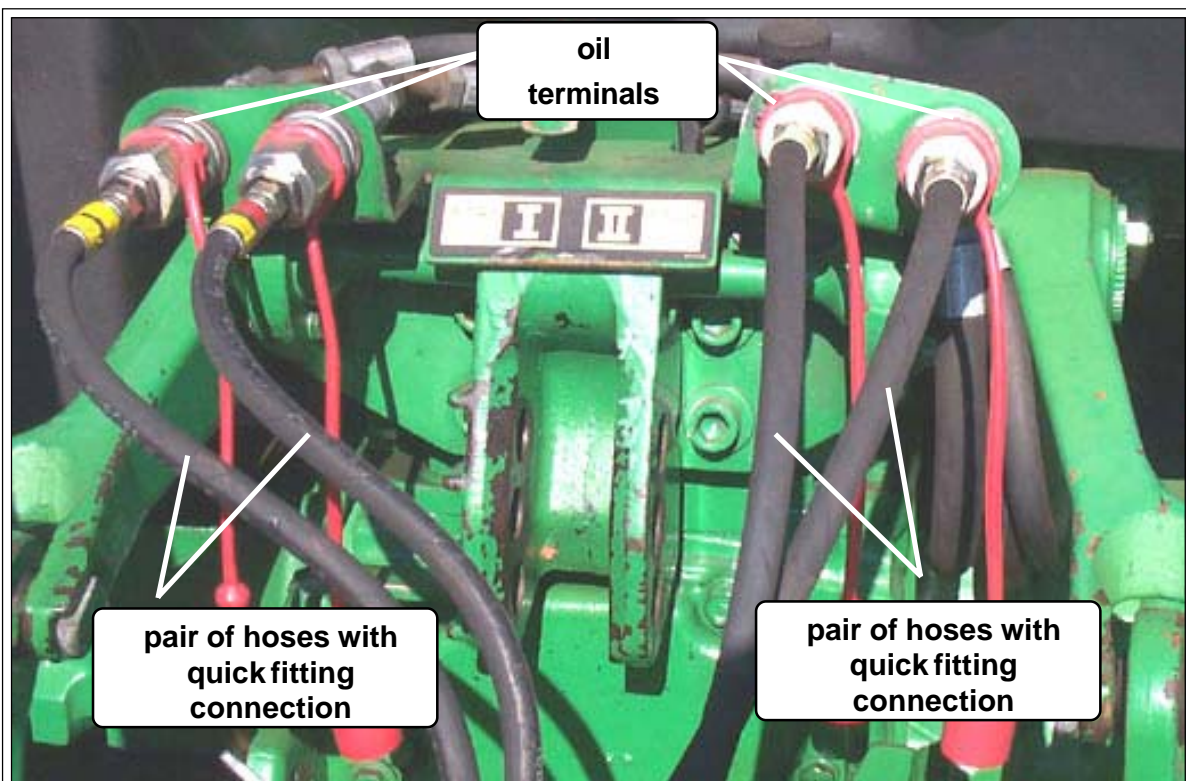

ATTENTION

ALWAYS BE CAREFUL WITH THE OIL QUANTITY AND QUALITY IN THE TRACTOR REMOTE CONTROL SYSTEM, IN ORDER TO AVOID ANY DAMAGE TO THE EQUIPMENT, AND KEEP THE HOSES INLETS PROTECTED.

OPERATION AND ADJUSTMENTS

SPRAY APPLICATION TECHNOLOGY

A successful spray application does not depend only on a good sprayer or correct use of the chemicals but also on factors to be determined in the field under specialized orientation.

Among these factors, some concepts should be part of a criterion of evaluation so that positive results may be attained within the pest control program.

- **Ideal time**
- **Safety**
- **Application rate**
- **Good coverage**

IDEAL TIME

The ideal time for spraying should be chosen according to the chemical product characteristics, as well as to the field conditions:

- Infestation level of pests, diseases and weeds;
- Infection level of diseases;
- Growing stage of weeds;
- Weather conditions.

SAFETY

When spraying your crops, you must make sure there will be no risk to people, animals and environment. Avoid spraying at hotter times, with humidity below 55% or under windy conditions.

Do not allow the operator to handle chemicals and spraying machinery without the proper individual protective clothing.

CORRECT APPLICATION RATE

Any type of application requires that the rate be maintained during the whole spraying work. This will be possible when you have a good sprayer properly calibrated.

This calibration can be obtained through practical methods or formulas. Please refer to the section **OPERATION AND ADJUSTMENTS - CALIBRATING THE SPRAYER.**

GOOD COVERAGE

You have a good coverage when the whole target is sprayed with uniform distribution, with no risk to the environment and with good results in the pest control.

The application rate does not have influence on the treatment results. Therefore good coverages can be attained even with different rates, which may vary according to operational and regional factors.

IMPORTANT!

READ CAREFULLY AND FOLLOW STRICTLY THE INSTRUCTIONS ON THE CHEMICALS MANUFACTURER'S LABEL.

ALWAYS FOLLOW DIRECTIONS OF A TECHNICIAN WHEN HANDLING AND APPLYING CHEMICALS.

ALWAYS MAKE SURE THE SPRAYER IS IN GOOD OPERATIONAL CONDITIONS BEFORE STARTING THE SPRAYING JOB AND EMPLOY A WELL TRAINED OPERATOR.

OPERATION AND ADJUSTMENTS

HOLLOW AND FULL CONE NOZZLES - SERIES J

HIGH QUALITY CERAMIC HIGH RESISTANCE TO WEAR

The alumina-sintered nozzles are almost as hard as diamond and resist yet the most corrosive chemicals. This ensures perfect stability for long time besides meeting the requirements for flow, coverage and droplet size.

These nozzles are recommended for fruit trees because of their excellent performance in high volume spraying.

NOTE: As there are many options for row spacing and number of nozzles per branch, we do not list any table showing the spraying volume as it can be obtained through the formula specified in the section OPERATION AND ADJUSTMENTS - CALIBRATING THE SPRAYER.

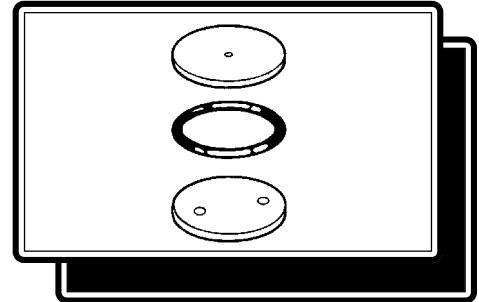

FLOW RATE TABLE

Nozzle model	Pressure (psi)							
	75	100	150	200	250	300	350	400
	Flow rate (gpm)							
*J4-2 hollow cone	0.28	0.32	0.40	0.45	0.50	0.54	0.59	0.63
J4 - 3 full cone	0.41	0.48	0.58	0.67	0.75	0.83	0.89	0.95
*J5 - 2 hollow cone	0.41	0.48	0.58	0.67	0.69	0.81	0.88	0.94
J5 - 3 full cone	0.70	0.80	0.97	1.13	1.26	1.38	1.49	1.60
J6 - 2 hollow cone	0.60	0.70	0.84	0.97	1.08	1.19	1.28	1.36
J6 - 3 full cone	1.17	1.34	1.63	1.89	2.11	2.30	2.48	2.66



Pressure band not recommended because it will cause premature wear to nozzles.

Nozzles mounted to the equipment (J4-2 = 52 nozzles / J5-2 = 52 nozzles)

ORDERING

Nozzle model	J4 - 2	J4 - 3	J5 - 2	J5 - 3	J6 - 2	J6 - 3	Ring
Part #	325423	819607	325431	327486	325449	327494	913335

Specify nozzle model and part #. Ex: J5-2, part # 325431.

OPERATION AND ADJUSTMENTS

HOLLOW CONE NOZZLE HIGH QUALITY CERAMIC SERIES JA

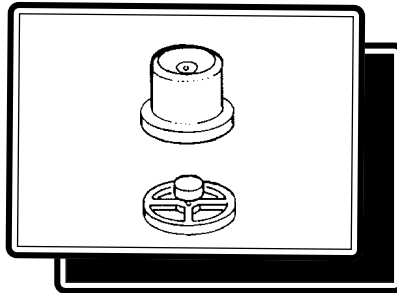

TECHNICAL CHARACTERISTICS

SPRAY PATTERN..... HOLLOW CONE
MANUFACTURING MATERIAL..... **CERAMIC**

Series JA hollow cone nozzles are produced by processes developed for exacting markets of mechanical engineering, space and aerospace industries. A special mold injection process makes a perfect orifice in the nozzles, giving better quality to the surface finish than that achieved by machines. The result is better coverage and more homogenous spraying.

These nozzles are approved by international quality standards, ensuring an outstanding spray cone uniformity and flow rate of nozzles.

The ceramic nozzles are almost as hard as diamond and resist the most corrosive products. This provides excellent stability for long life considering requirements such as flow rate, coverage and droplet size.

TABLE 01 - FLOW RATE



Pressure (psi)	Nozzle model					
	JA - 1	JA-1.5	JA-2	JA-3	JA-4	JA-5
	Flow rate (gpm)					
30	0.06	0.08	0.12	0.16	0.24	0.31
45	0.07	0.10	0.14	0.20	0.29	0.36
60	0.08	0.11	0.17	0.23	0.33	0.42
90	0.10	0.14	0.20	0.28	0.39	0.51

NOZZLES STRAINERS: Use 50 or 60 mesh for all nozzle models.

OPERATION AND ADJUSTMENTS

Nozzle		Pressure (psi)	Flow rate (GPM)	Tractor speed (MPH)								
Model	Color			2.5	3	4	4.5	5	5.5	6	6.5	7.5
		Spraying volume (GPA)										
JA - 1	Blue	60	0.08	10.26	8.22	6.84	5.87	5.13	4.60	4.06	3.74	3.42
		90	0.10	12.18	9.72	8.12	6.94	6.09	5.45	4.91	4.38	4.06
		150	0.13	16.03	12.82	10.68	9.19	8.00	7.16	6.41	5.87	5.34
		210	0.14	17.63	14.10	11.75	9.94	8.87	7.80	7.05	6.41	5.87
JA - 1.5	Brown	60	0.11	13.78	11.00	9.20	7.90	6.95	6.09	5.55	5.02	4.60
		90	0.14	16.67	13.35	11.11	9.51	8.33	7.37	6.62	6.09	5.55
		150	0.17	21.16	16.88	14.10	12.07	10.58	9.40	8.44	7.70	7.05
		210	0.20	24.68	19.77	16.45	14.10	12.40	11.00	9.83	8.97	8.22
JA - 2	Black	60	0.17	20.52	16.45	13.68	11.75	10.26	9.08	8.22	7.48	6.84
		90	0.20	24.36	19.45	16.24	13.90	12.18	10.80	9.72	8.87	8.12
		150	0.26	32.06	25.65	21.37	18.27	16.03	14.21	12.82	11.65	10.68
		210	0.30	36.23	28.96	24.15	20.73	18.16	16.13	14.53	13.14	12.07
JA - 3	Orange	60	0.23	28.21	22.55	18.81	16.13	14.10	12.50	11.32	10.26	9.40
		90	0.28	34.00	27.14	22.65	19.45	17.00	15.06	13.57	12.40	11.32
		150	0.35	42.96	34.41	28.64	24.58	21.48	19.13	17.20	15.60	14.32
		210	0.41	50.33	40.30	33.55	28.75	25.22	22.33	20.09	18.27	16.77
JA - 4	Red	60	0.33	40.07	32.06	26.71	22.87	20.09	17.84	16.03	14.53	13.35
		90	0.40	48.41	38.68	32.27	27.68	24.26	21.48	19.34	17.63	16.13
		150	0.50	61.23	48.95	40.82	34.95	30.67	27.25	24.47	22.23	20.41
		210	0.59	71.17	56.96	47.45	40.72	35.58	31.63	28.42	25.86	23.72
JA - 5	Green	60	0.42	51.30	41.04	34.20	29.28	25.65	22.76	20.52	18.70	17.10
		90	0.51	61.88	49.50	41.25	35.37	31.00	27.46	24.80	22.55	20.62
		150	0.64	78.23	62.62	52.15	44.67	39.11	34.73	31.31	28.42	26.07
		210	0.75	91.37	73.10	60.91	52.26	45.74	40.61	36.55	33.23	30.45

Ordering: Specify nozzle model and part #. Ex.: nozzle JA-2, part # 000026.

Color	Blue	Brown	Black	Orange	Red	Green
Model	JA - 1	JA - 1,5	JA - 2	JA - 3	JA - 4	JA - 5
Part #	109744	454256	000026	454264	454272	454280

OPERATION AND ADJUSTMENTS

CALIBRATING THE SPRAYER

The safety of people, animals and environment depends on correct spray applications. Therefore, we list below some operational procedures.

WHEN HANDLING THE CHEMICALS

- Follow strictly the instructions on the labels.
- Use individual protective equipment.
- Do not eat, drink or smoke.
- Choose a ventilated place.
- Wash with water and soap the parts of the body touched by chemicals.

WHEN HANDLING THE SPRAYER

- Check for the proper working conditions of the sprayer.
- Do not blow by mouth nozzles, valves or tubes.
- Do not spray against the wind.
- Do not spray in hotter times.
- Use individual protective clothing recommended.
- Do not eat, drink or smoke.

REMEMBER

You are responsible for the success of the application.

PROCEDURE

The sprayer can be calibrated by obtaining the spraying volume through the following formula:

$\text{GPA} = \frac{\text{GPM} \times 495}{\text{MPH} \times \text{S}}$	Where: GPA - Spray volume GPM - Total nozzles flow rate S - Spray swath (ft) MPH - Tractor speed (mph) 495 - Conversion unit
$\text{GPM} = \frac{\text{GPA} \times \text{MPH} \times \text{S}}{495}$	

EXAMPLE:

Spray volume 16 gpa
Spray swath 82 ft
Tractor speed 2.5 mph

$$\text{GPM} = \frac{\text{GPA} \times \text{MPH} \times \text{S}}{495}$$

$$\text{GPM} = \frac{16 \times 2.5 \times 82}{495}$$

$$\text{GPM} = 6.6$$

ATTENTION

The figures shown in the example above are illustrative only. The correct calibration must be done according to the recommendations of technician.

OPERATION AND ADJUSTMENTS

DILUTING THE CHEMICALS

ATTENTION

NEVER run the sprayer for with less than 13 gallons of water in the tank to avoid damage to the pump.

Always use the following individual protective clothing when handling chemicals:

- Impermeable wide-brimmed hat
- Goggles
- Mask
- Long-sleeved working clothes
- Impermeable gloves
- Impermeable boots

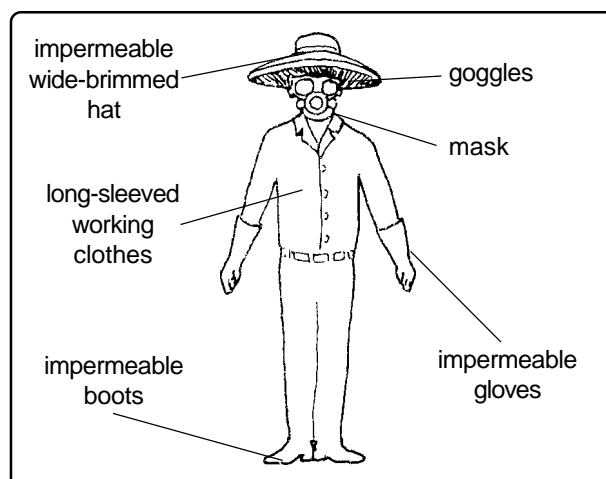

PREPARING THE CHEMICAL MIXER

ATTENTION

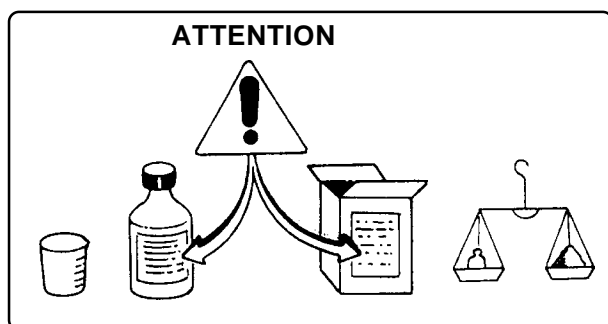

- Read carefully the chemicals manufacturer's label.

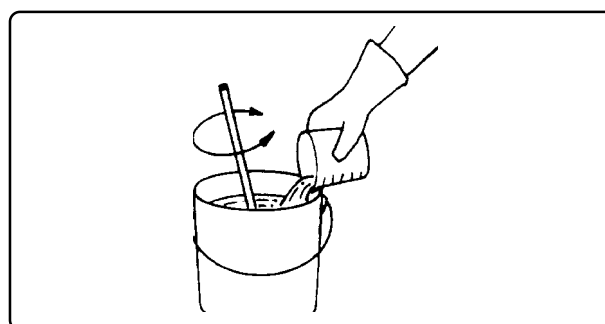

- Pour the chemicals into a bucket with little water and stir.

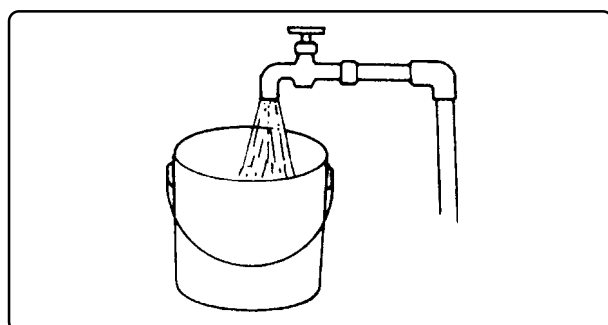

- Add water until filling the bucket up.
- Stir until the mixture is homogeneous.

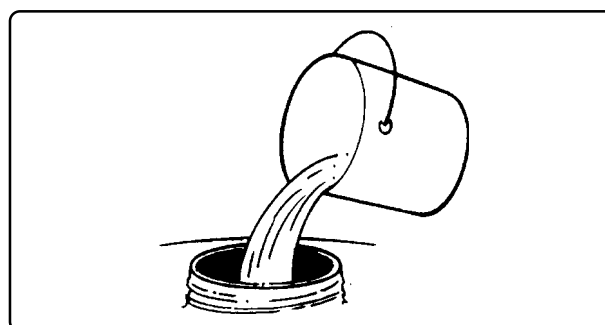

- Pour the solution into the sprayer's tank.
- Install the tank lid and make sure there is no leakage.

ATTENTION
ALWAYS FOLLOW TECHNICAL RECOMMENDATIONS
WHEN HANDLING CHEMICALS.

OPERATION AND ADJUSTMENTS

CHEMICAL CONTAINER RINSE

The chemicals are packaged in appropriate containers for each type of product.

After emptying the containers, they must be discarded in a safety way, in order not to poison the man and the environment.

It is very important, before any discard of empty containers, to remove the residues of the product that are stuck inside.

Metal, plastic and glass containers must be rinsed for decontamination.

To facilitate this important operation, Jacto has installed on its trailed sprayers a suitable device that rinses internally the containers with pressurized water, eliminating most of the residues.

On the J2600, the chemical container rinse device is consisted of the following items:

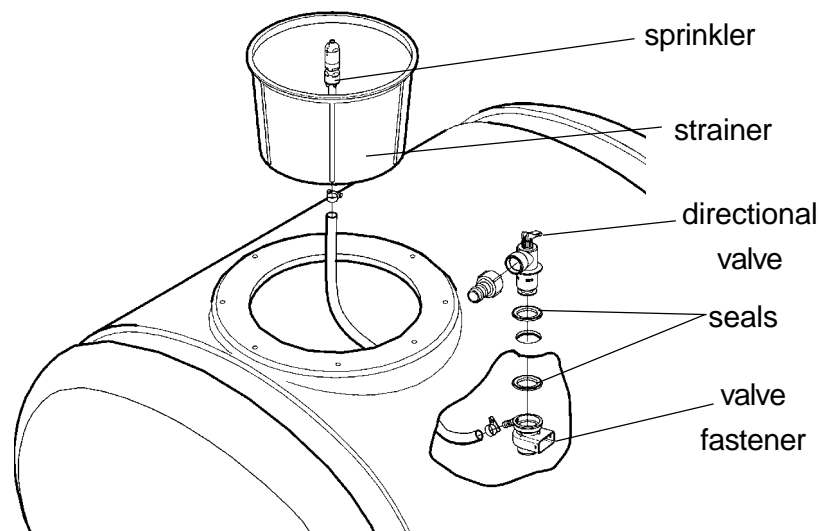

PROCEDURES

- Fill the chemical tank up to approximately 90% of its capacity.
- Pour the chemical into the tank.
- Engage the tractor PTO.

NOTE: The relief lever of the chemical control must be set to allow the chemical return to the tank (off).

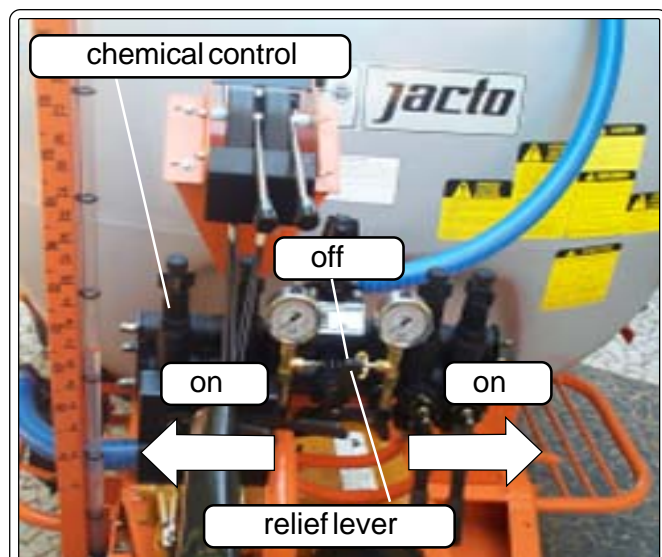

ATTENTION: USE THE RECOMMENDED PROTECTIVE CLOTHING FOR THIS OPERATION.

OPERATION AND ADJUSTMENTS

- Hold the chemical container over the rinse nozzle and pull the directional valve lever to wash inside the container.

NOTE: With the chemical container over the rinse nozzle, make circular movements to reach all internal walls of the chemical container with the water jet for around 30 seconds.

- Fill up the sprayer tank with water.

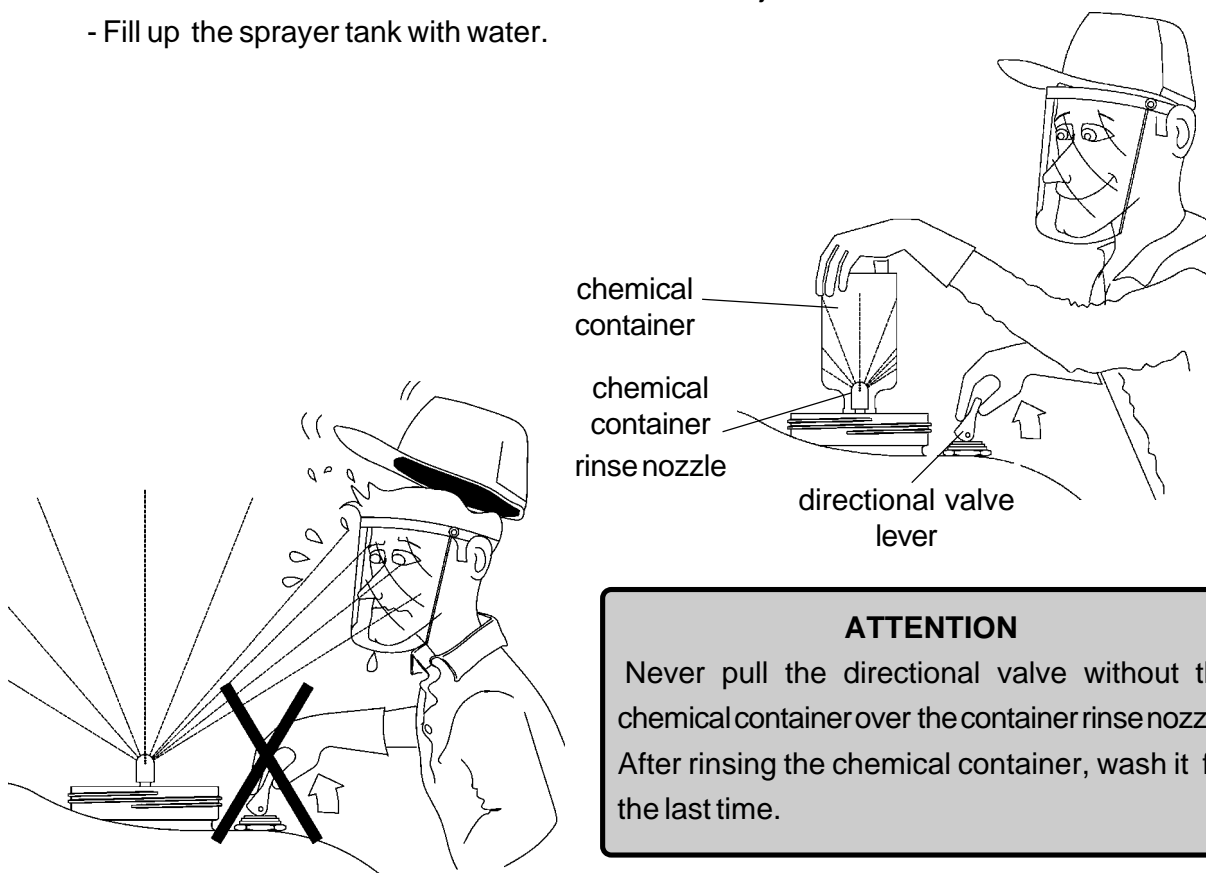

ATTENTION

Never pull the directional valve without the chemical container over the container rinse nozzle. After rinsing the chemical container, wash it for the last time.

WASHING THE CHEMICAL CONTAINER

- Fill the chemical container with water up to 1/4. Fit the container cap and tight it enough to avoid leakage during the agitation.

- Agitate the container strongly in all ways (horizontal and vertical), during approximately 30 seconds to remove the residues that are stuck to the container internal walls.

- Take the container cap off and carefully pour the rinse water into the spray tank.

- Keep holding the container over the spray tank opening until the last drop.

- Next, make the container useless by piercing it. This way, their labels are not damaged for identification purposes.



OPERATION AND ADJUSTMENTS

FLOW RATE TABLE - J-2600

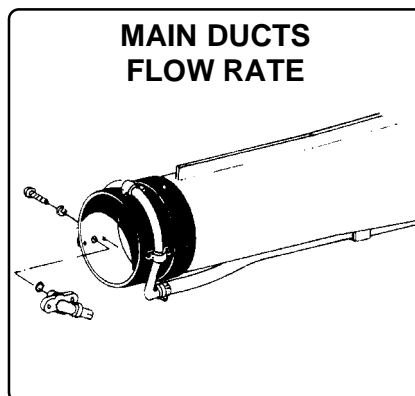
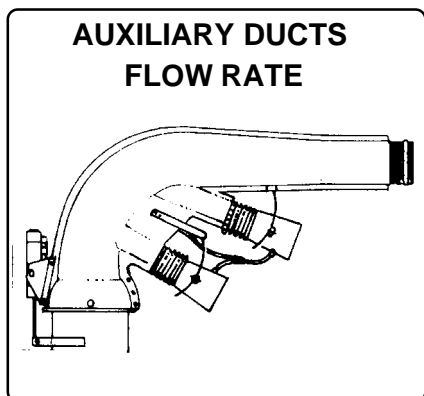

PRESSURE (PSI)	MAIN DUCT FLOW RATE (gpm)			TOTAL FLOW RATE (gpm)		
	A*	B*	C*	AUXILIARY DUCTS		
				JA-1	JA-2*	JA-4
0	0.84	1.32	1.05	0.09	0.22	0.30
10	2.50	2.64	2.50	0.21	0.41	0.73
20	3.83	3.96	3.83	0.29	0.57	1.06
30	5.02	4.88	4.75	0.35	0.79	1.29
40	5.94	5.68	5.81	0.41	0.81	1.50
50	6.60	6.34	6.47	0.46	0.90	1.69
60	7.13	7.26	7.13	0.49	1.00	1.84
70	7.92	7.80	7.66	0.53	1.09	1.99
80	8.45	8.32	8.19	0.57	1.16	2.16

* JA-2 - Nozzle model installed on the auxiliary ducts.

Flow rate A* in the main duct it is obtained when the nozzles JA-1 are used in the auxiliary ducts.
 Flow rate B* in the main duct: it is obtained when the nozzles JA-2 are used in the auxiliary ducts.
 Flow rate C* in the main duct: it is obtained when the nozzles JA-4 are used in the auxiliary ducts.

NOTE: For a more homogeneous distribution of the chemical mixture along the spray swath, it is recommended to install on the auxiliary ducts the nozzles shown in the table above according to the setting of the flow rate regulating valve.

ATTENTION: The figures shown in the table above have been obtained with water applications. Therefore, there may be variations due to the viscosity of the liquid to be applied.

SELECTING THE SPRAY SWATH

Select the spray swath according to the plant growing stage, kind of pest or disease, chemicals to be applied and weather conditions.

The table beside shows some suggestions of spray swath. In course of the applications, the operator should determine the spray swath most appropriate to the working conditions.

IMPORTANT:

- Always spray at cooler times of the day.
- The rotation of PTO must be 540 rpm.
- Spray with light wind (maximum of 16 mph).
- Make sure the swath determined is being sprayed.

CHEMICALS	SPRAY SWATH (ft)	
	WORK BEGINNING	MAXIMUM
Fungicides	50	82
Insecticides	65	115
Herbicides for pasture	50	100

OPERATION AND ADJUSTMENTS

TRACTOR PATH AND DUCT INCLINATION

The figures below show how to make the spray application and adjust the duct according to the tractor speed and wind direction.

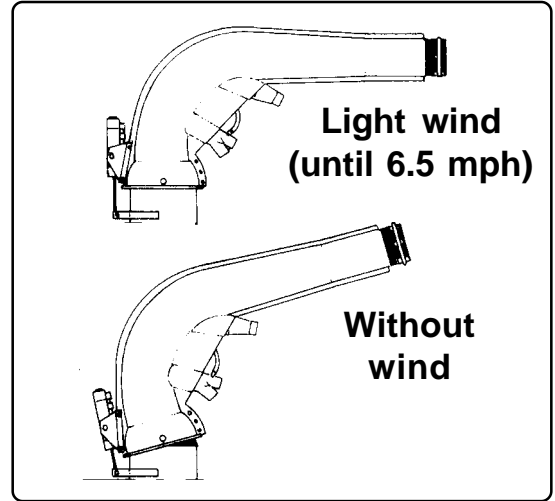
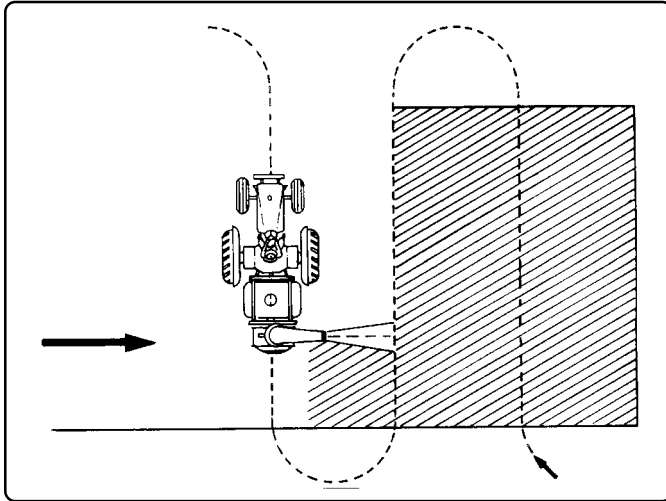

ADJUSTING THE AUXILIARY DUCTS ON THE J2600

Adjust the auxiliary ducts so that the spray covers the area close to the tractor to avoid failures in the application.

ATTENTION

- Turn off the duct before stopping or maneuvering the tractor.
- Never spray against the wind.
- Never spray with strong winds.
- Never spray during hotter times.

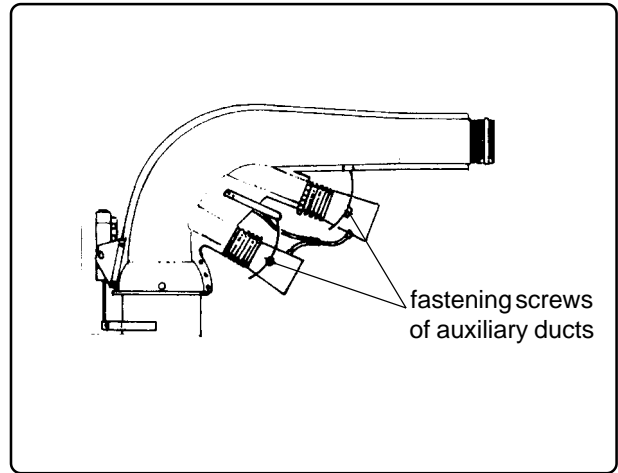

IMPROPER CONDITIONS TO SPRAY:

- With strong wind and high temperature.
- Against the wind.

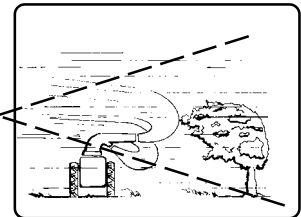
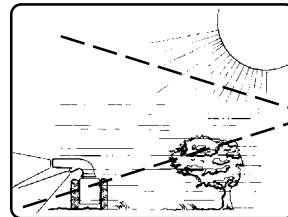

PROPER CONDITIONS TO SPRAY:

- At cooler times of the day, that is, early in the morning or late in the afternoon.
- With the wind (light wind).

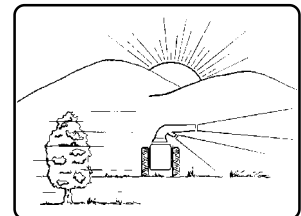
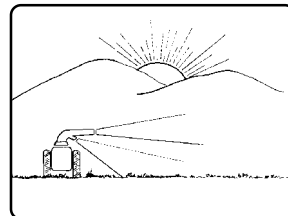

IMPORTANT:

Always use appropriate individual protective clothing such as: working clothes, mask, gloves, etc.

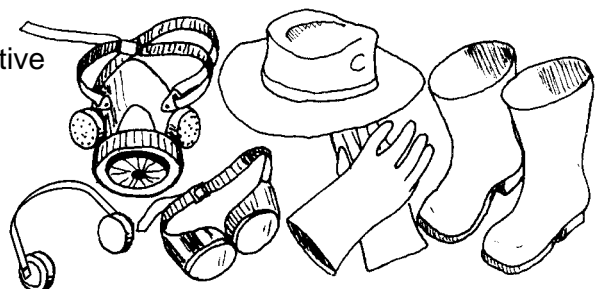

MAINTENANCE

GUIDELINES

After the first working hours, check if the bolts, nuts, clamps on the tanks, wheel and axle are well installed. Retighten them if necessary.

Daily, after finishing the spray application, put clean water in the tank, remove the nozzles and run the sprayer till empty.

Clean and reinstall the nozzles.

Clean the main filter.

Rinse off the inside and outside of the sprayer.

ATTENTION

NEVER WASH SPRAYERS OR INDIVIDUAL PROTECTIVE EQUIPMENT IN OR CLOSE TO RIVERS, LAKES, STREAMS, BROOKS, DAMS, ETC.

Take off and wash the individual protective clothing separated from other clothes.

Take a shower with plenty of water and soap and change your clothes.

These procedures will avoid future problems caused by strainer, nozzle and tube obstructions and prolong the sprayer's life, as well as protect yourself.

COMPONENTS

MAIN FILTER

- The frequency of filter cleaning will depend on the quality of water and type of agrochemicals applied.

- Clean the filter when filling the tank or whenever necessary.

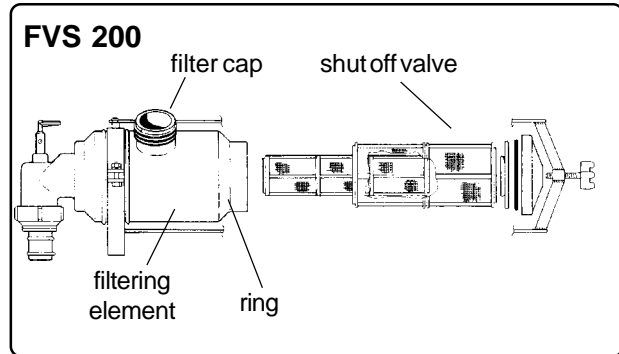

PRESSURE REGULATOR (VDC)

- Disassemble the pressure regulator every 100 working hours.
- Check for wear on the valve and valve seat.
- Replace the parts if necessary.

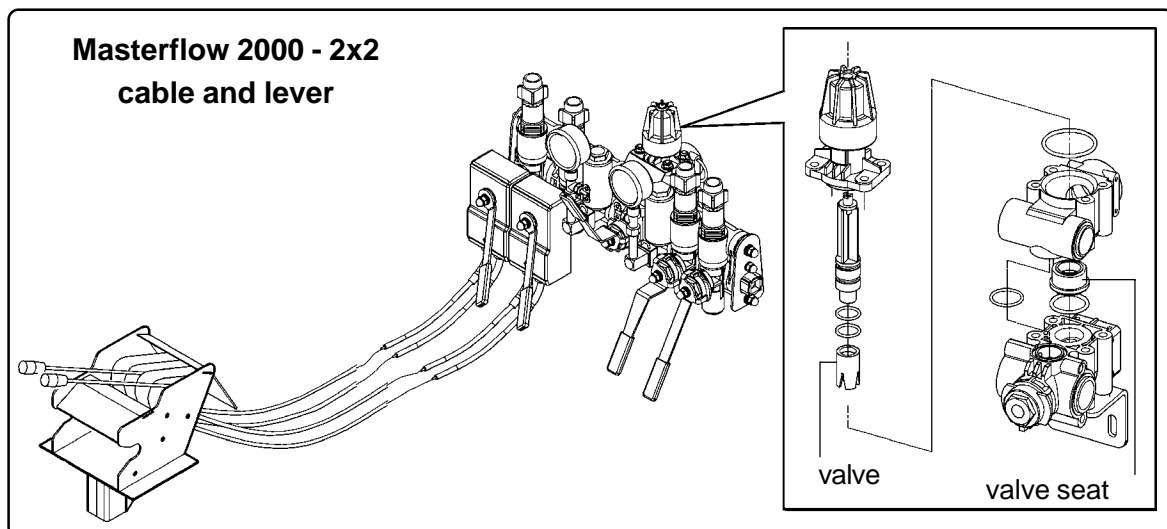

MAINTENANCE

AUXILIARY AND MAIN DUCTS

Remove the auxiliary duct s nozzles and filters and the main duct deflector nozzles for cleaning daily or whenever necessary.

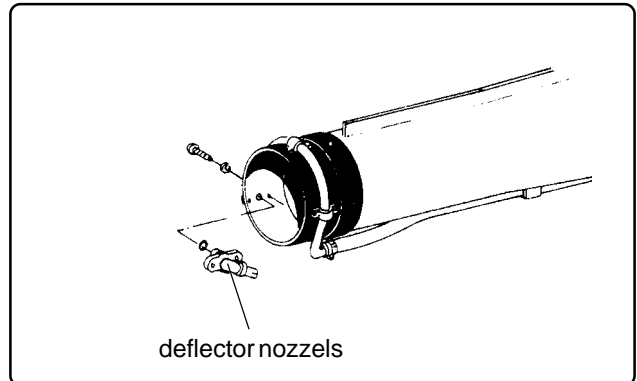
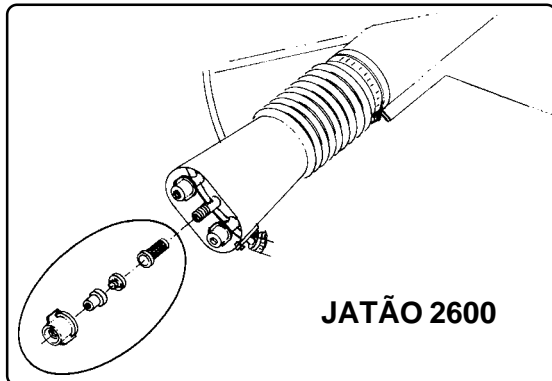

COMPONENTS LUBRICATION

PUMP

Check the pump oil level daily and fill it if necessary.

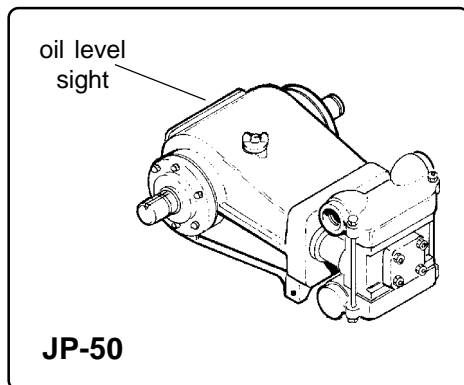

MECHANICAL AGITATOR

If the agitator assembly leaks, proceed as follows:

- Loosen the nut (1) by turning it clockwise.
- Tighten the screw (2) pressing the gasket till it stops leaking.
- Retighten the nut (1) and lubricate the agitator.

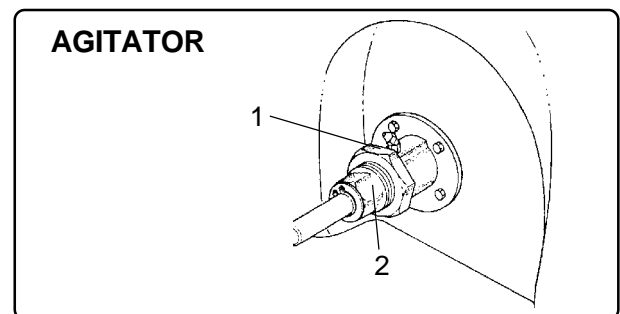

GEARBOX

Check on the maintenance table the frequency, quantity and type of the lubricant oil used in the gearbox. The gearbox oil level must be checked daily.

If necessary, fill up until reaching the duct filling plug.

Release the drain nut to drain the oil.

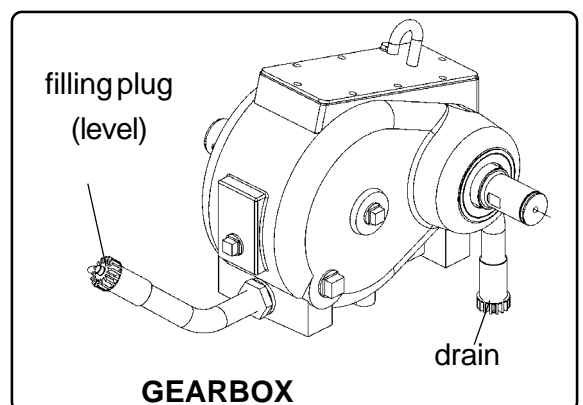

WHEEL HUB

Replace the grease every 500 working hours according to specifications in the lubrication table.

Place the sprayer on a firm and level ground and scotch its wheels before lubricating the wheel hub.

MAINTENANCE

LUBRICATION TABLE

PRODUCT	LOCATION	QTY.	FREQUENCY	SPECIFICATION	RECOMMENDED PRODUCTS
LUBRICANT OIL	JP - 50 PUMP	0.4 gallon	1ST CHANGE: AFTER THE FIRST 30 HOURS. FURTHER CHANGES: EVERY 100 HOURS	API - SB OR SUPERIOR SAE - 30	ALL INTERNAL COMBUSTION ENGINES WITHIN THIS SPECIFICATION
	JP - 100 PUMP	0.5 gallon			
GREASE	PTO SHAFT, TRAILER'S HITCH, REAR AND FRONT BEARINGS, MECHANICAL AGITATOR, AND JACK	-	DAILY	LITHIUM BASE NGLI - 2	MULTIFAK EP - 2 MOBIL GREASE 77 LUBRAX GMA - 2 BEACON EP - 2 OR SIMILAR TYPE
	WHEEL HUB		500 HOURS		
GEARBOX	LUBRICANT OIL	0.4 gallon	API GL-5 SAE-90	MULTIGEAR LUBRICANTE EP-90 (TEXACO) MOBILUB HD-90 (MOBIL) IPERGEROL SP-90 (IPIRANGA) SIMILARS	0.4 GALLONS

NOTE: The presentation order of the recommended products does not imply preference for any brand or product.

LUBRICATION POINTS

- 1 - PTO shaft cross and tubes (Refer to the section MAINTENANCE - PTO SHAFT)
- 2 - Jack
- 3 - Trailer's hitch
- 4 - Mechanical agitator
- 5 - Rear bearing
- 6 - Spray ducts



ATTENTION
ALWAYS STOP THE SPRAYER AND TURN OFF THE TRACTOR ENGINE
BEFORE ANY KIND OF MAINTENANCE.

MAINTENANCE

TRACK WIDTH AND GROUND CLEARANCE

TRACK WIDTH

TIRES	TRACK WIDTH (in)	
	MINIMUM	MAXIMUM
7.5-16	48.6	35.2

GROUND CLEARANCE

TIRES	GROUND CLEARANCE (in)	
	MINIMUM	MAXIMUM
7.5-16	8.3	14.5

ADJUSTING THE TRACK WIDTH

- Raise the trailer back enough to suspend the wheels over the ground.
- Loosen the 4 nuts (1) that fasten the sliding end to the axle.
- Slide the axle end measuring the distance from the tire inner face to the chassis outer face. (example in the detail A).

NOTE: Depending on the sprayer and on the track width desired, it may be necessary to adjust the locking bolt for the high axle. Then you should adjust according to the recommendations in the table "Recommended Minimum Track Width (in)".

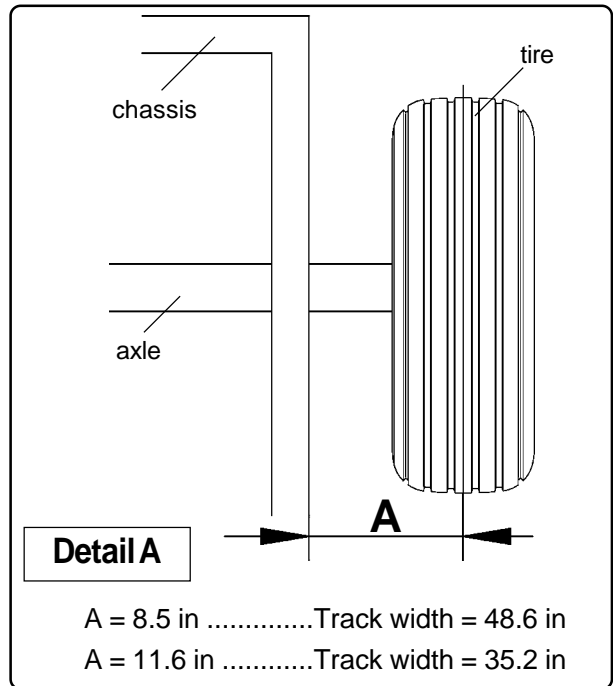
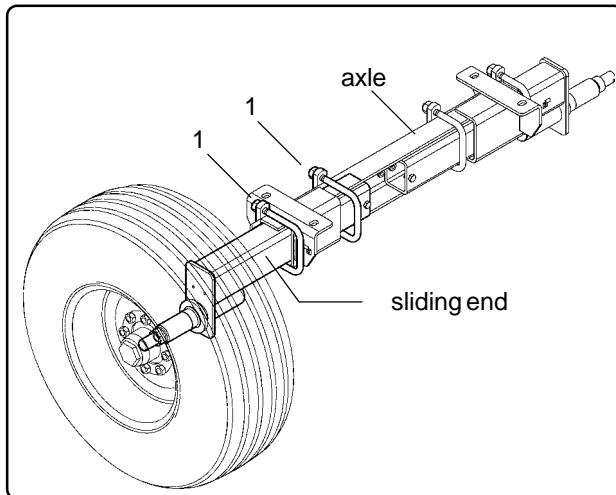

ADJUSTING THE GROUND CLEARANCE

- Raise the trailer back enough to suspend the tires over the ground.
- Loosen the 4 nuts (1) that fasten the sliding end to the axle.
- Remove the bolt (2) that stops the movement of the sliding end.
- Invert the assembly of the axle sliding end as shown in the figures beside.
- Fit the sliding end in the desired position.
- Loosen the 4 nuts (1).
- Fit the bolt (2).

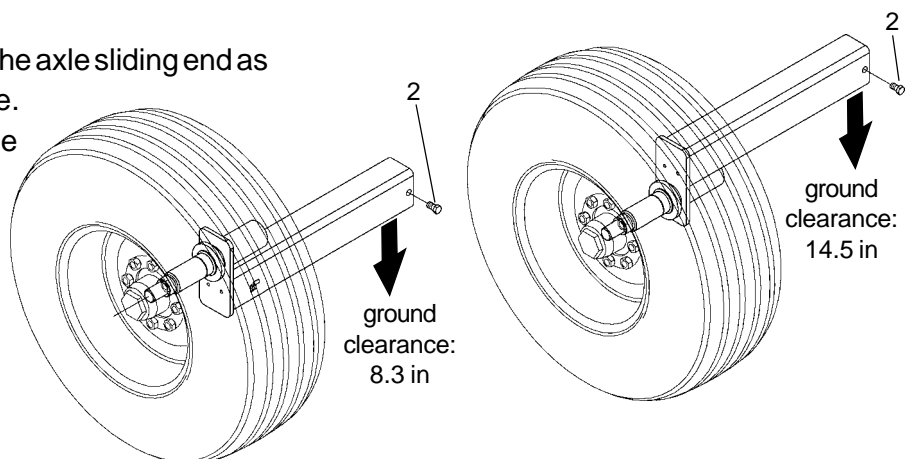

MAINTENANCE

TRACK WIDTH ADJUSTMENT

SAFETY INSTRUCTIONS

- The maximum working speed for the J-2600 sprayer must not exceed 4 mph.
 - The maximum speed for moving around the J-2600 sprayer must not exceed 6.5 mph.
 - NOTE: For both moving around and working with the sprayer, it is important to have the axle assembled according to the recommendations in the table below. Preferably, for moving around the sprayer at speeds above 5 mph, set the axle with the maximum track width and minimum ground clearance.
 - Avoid moving on irregular ground. If it is necessary and the axle is set in the minimum recommended assembly, you must take double care.
 - ATTENTION: Irregular ground risks operator's safety and sprayer.
 - The axle on the J - 2600 sprayer is assembled with bolts to block the track width adjustment way when set to high axle. The position of these bolts varies according to the sprayer type.
- To adjust the track width and ground clearance, proceed as follows:

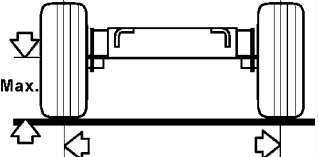
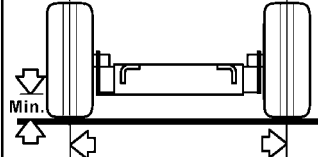
	BITOLA (in) MÍNIMA RECOMENDADA	
	RECOMMENDED MIN. TRACK WIDTH (in)	TROCHA (in) MÍNIMA RECOMENDADA
		
ARBUS 2000 VALÊNCIA / CERRADO	61	55
ARBUS 2000 EXPORT / USA	61	48.4
ARBUS 1500-2000 GOLDEN	61	48.4
ARBUS 1500 DIAMOND	61	48.4
ARBUS 2000 CAFÉ	56.7	48.4
J-2600	56.7	48.4

ATTENTION: To adjust the track width, be alert to the position of the locking bolt, and adjust according to the dimensions recommended in above table.

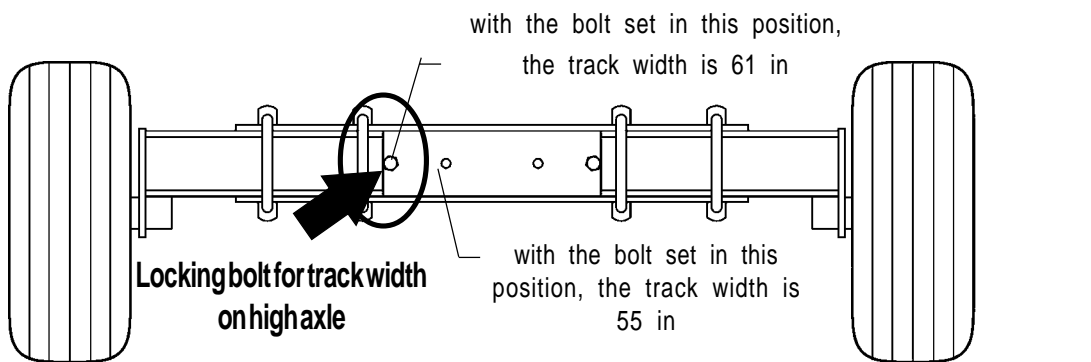

MAINTENANCE

CONVENTIONAL PTO SHAFT

ATTENTION: ALWAYS STOP THE SPRAYER AND TURN OFF THE TRACTOR ENGINE BEFORE SERVICING THE PTO SHAFT. ALL KIND OF MAINTENANCE ON THE PTO SHAFT MUST BE DONE WITH THE USE OF APPROPRIATE PROTECTIVE CLOTHING, SUCH AS: GLOVES, BOOTS, GOGGLES, ETC.

01- CONNECTING

- Check the PTO shaft length.
- Adjust the length by cutting the tubes and protection guards proportionately.

Note: File and remove all burrs.

- Connect the PTO shaft and install the safety chain.

Note: Leave some slack on the chain considering angular movements.

- Disengage the PTO when making sharp turns.

Lubricate the male and female tubes and further points as the figure 1.

ATTENTION
ONLY OPERATE WITH PTO SHAFT
EQUIPPED WITH PROTECTION GUARDS.

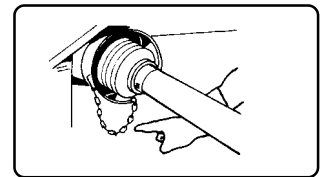
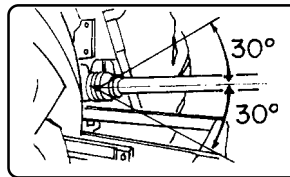
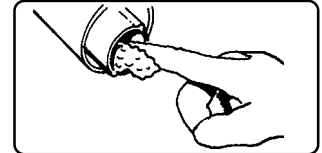
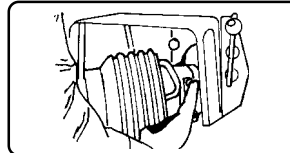
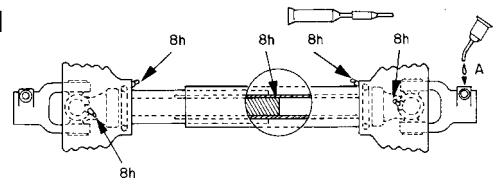

fig 1



02- SERVICING

a) DISASSEMBLING

- 1- Remove the lock screw.
- 2- Turn the guard cone until the indicated position.
- 3- Pull the guard cone.
- 4- Remove the sliding ring.

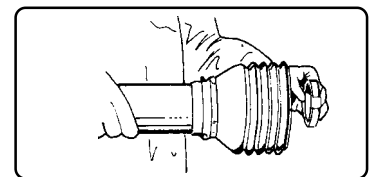
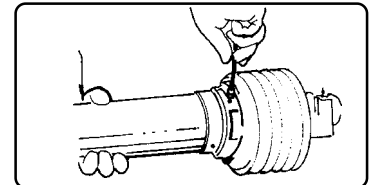
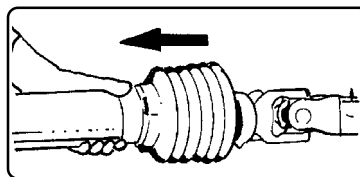
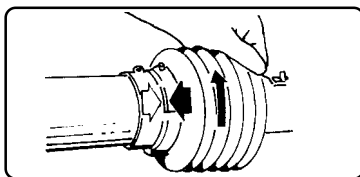

b) ASSEMBLING

- 5- Clean and lubricate the male and female tubes.
- 6- Install the sliding ring into the fitting with the grooves pointing toward the tube.

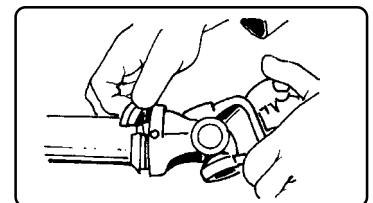
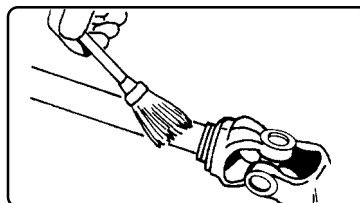

- 7- Install the protection guards.

- 8- Turn the guard cone until the indicated position.

- 9- Install the lock screw.

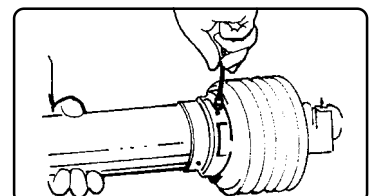
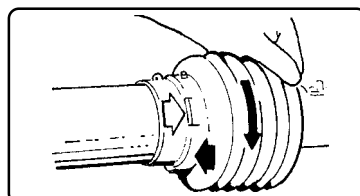
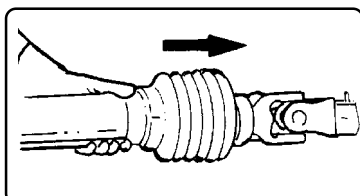

MAINTENANCE

WIDE-ANGLE C.V. PTO SHAFT

ATTENTION: ALWAYS STOP THE SPRAYER AND TURN OFF THE TRACTOR'S ENGINE BEFORE SERVICING THE PTO SHAFT.

The **WIDE-ANGLE CV PTO SHAFT** is a component whose advantage in relation to standard PTO shafts is to allow turns at angles up to 75° with no need to disengage the PTO.

ATTENTION: ONLY OPERATE WITH PTO SHAFT EQUIPPED WITH PROTECTION GUARD. ALWAYS USE THE INDIVIDUAL PROTECTIVE EQUIPMENT DURING THE MAINTENANCE OF THE PTO SHAFT.

INSTRUCTIONS

1 - LUBRICATION

- Lubricate the points indicated in the figure **A** every 8 working hours.

NOTE: The points (7) and (8) are opposite the points (1) and (3), so turn the guard cone as shown in the figure **A**.

NOTE: Every thirty/fifty working hours dismantle the protection guards, clean and wash the parts, lubricate and assemble the PTO shaft.

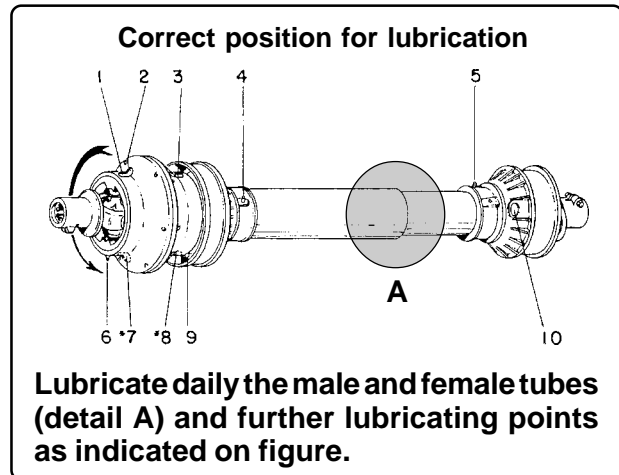

ATTENTION: Only lubricate the PTO shaft with the CV joint aligned to the male and female tubes; otherwise, the lubrication will not be appropriate and the PTO shaft can be damaged.

2 - CONNECTING THE PTO

- Adjust the sprayer's tongue and the tractor's drawbar so that there is an overlap from 1.2 to 2 in when the tractor is making a sharp turn (that is, when the tractor's tire is touching the sprayer's frame head).

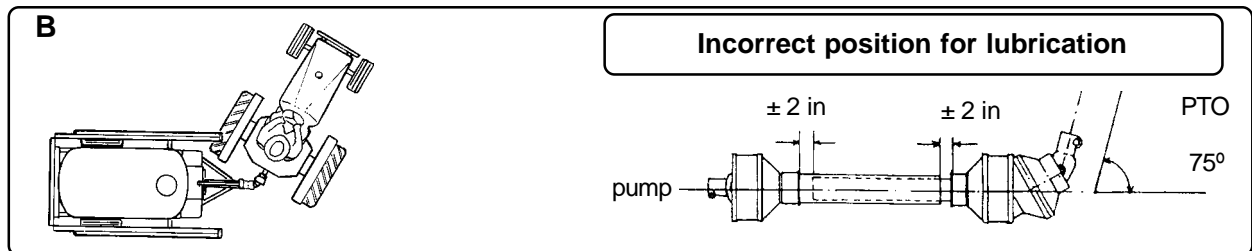

3 - DISASSEMBLING THE PTO SHAFT FOR LUBRICATION

- Hold the shaft as shown in the figure **C**, push the guard cone (1) down and simultaneously press the three locks (2) with a point or screw-driver. Thus the guard cone (1) will slip on the guard tube (3) and can be removed.

- Remove the locking collar (4) and disconnect the guard tube (3) from the shaft.

- Do the same shown in the figures **C** and **D** with the C.V. joint end and set apart its components.

- Clean all parts with a brush by using kerosene or gas oil and water and dry them next.

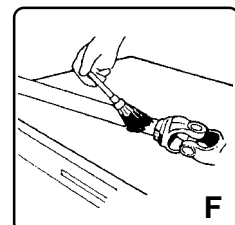
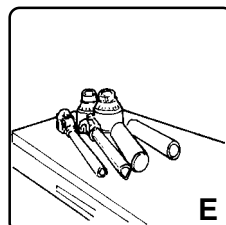
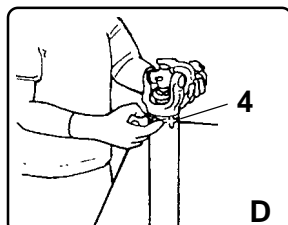
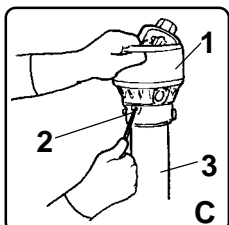

MAINTENANCE

WIDE-ANGLE C.V. PTO SHAFT

4 - REASSEMBLING

- Grease the locking collar groove (figure **G**).
- Install the guard tube (3) and fasten it with the locking collar (4) (figure **H**).
- Hold the shaft as shown in the figure **H** and slip the guard cone (1) on. Align the grease cup of the guard cone (1) with the bearing tab on the locking collar (4) (figure **J**).
- Push the guard cone (3) so that it is engaged by the locks (2).
- Make sure the 3 locks (2) are firmly engaged. If necessary, force close to the locks (2) as shown in the figure **J**.
- Do the same with the other end of the shaft and lubricate the whole assembly as shown in the figure **A**.

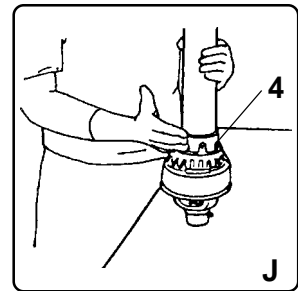
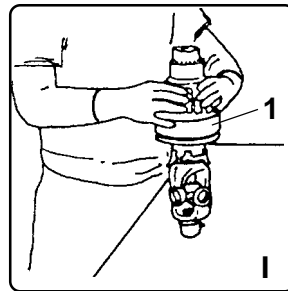
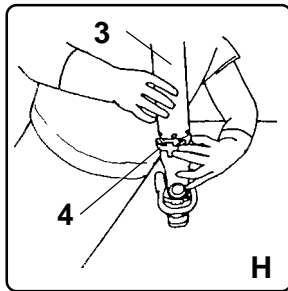
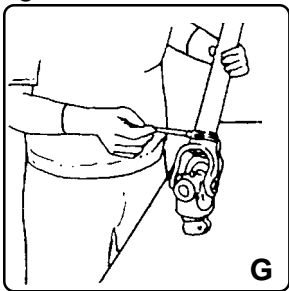

5 - ADJUSTING THE PTO SHAFT LENGTH

a) Before cutting the PTO shaft, **check if it is possible to use it without reducing its length.**

Check:

- The position on the tractor's drawbar.
- If the sprayer's tongue can be adjusted for longer.

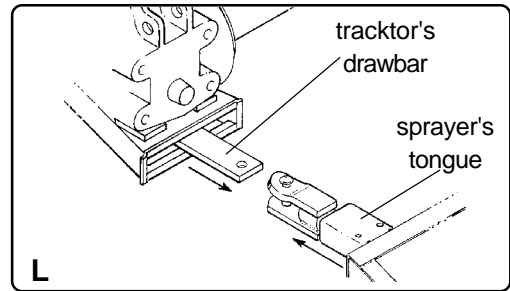

b) Cutting the shaft

- Dismantle the protection guards as shown in the figures **C** and **D**.
- Cut the two tubes (male and female) at the desired dimensions (figure **M**).
- Remove the burrs resulting from the cutting operation as well as the filings resulting from the burrs removal (figure **N**).
- Cut the guard tubes length using as measure reference the pieces of the tubes cutted (figure **O**).
- Clean the residues of cutting.

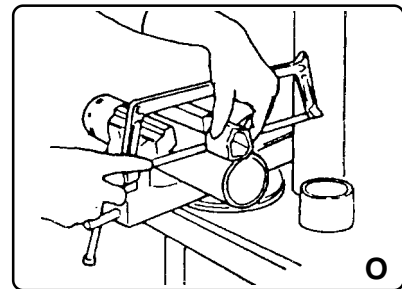
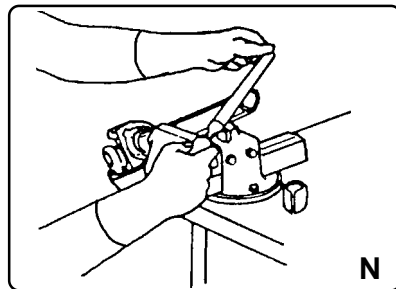
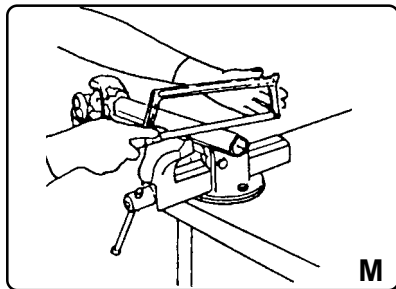

c) Assembling

- Assemble the PTO shaft as shown in the figures **G**, **H**, **I**, and **J** and lubricate it if necessary.

ATTENTION

ONLY OPERATE THE PTO SHAFT WITH SAFETY PROTECTION.

MAINTENANCE

BELTS TENSION

- Check the belts tension periodically.
- Press the agitator belts as shown in the figure beside. When pressed it should slack 0.4 to 0.6 in. **DO NOT USE SHARP-ENDED OR CUTTING TOOL**

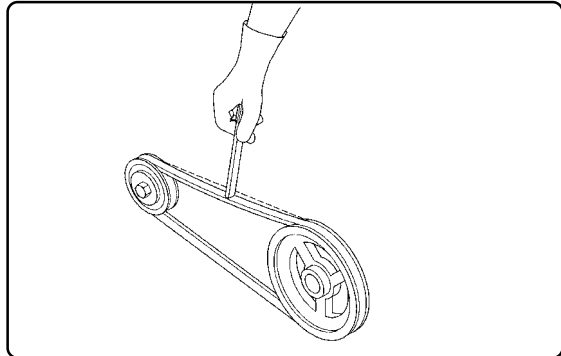

AGITATOR BELT

- Loosen the nut (1) that fastens the tension pulley of the agitator belt.
- Then use a lever to slide the pulley (2) until obtaining the required tension for the proper operation of the agitator.
- Retighten the nut (1).

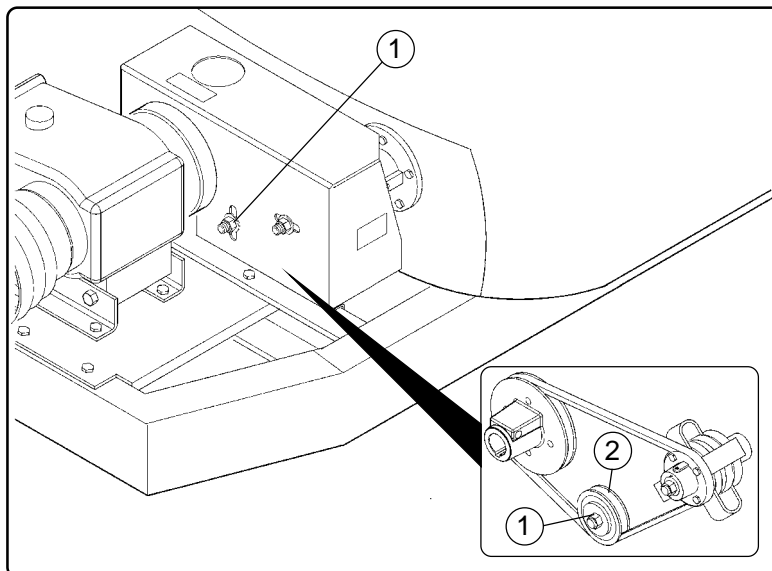

FAN BELT

- Loosen the four bolts (1) enough to allow the frame to be moved.
- Loosen the two nuts (2).
- Hand-tighten the two knobs (3) equally until obtaining the recommended tension for the belts.
- Retighten the two nuts (2).
- Retighten the four bolts (1).

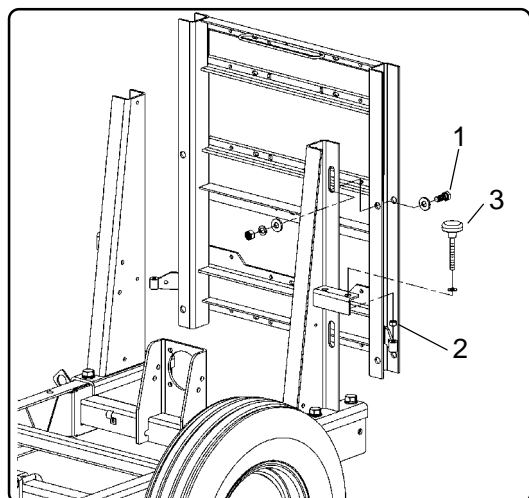

ATTENTION
ALWAYS STOP THE SPRAYER AND TURN OFF THE TRACTOR'S ENGINE
BEFORE ANY KIND OF MAINTENANCE.

MAINTENANCE

WINTER SOTAGE

ATTENTION: In regions where temperatures drop to 32 Fahrenheit or less, the water accumulated in the pump can freeze and cause serious damage.

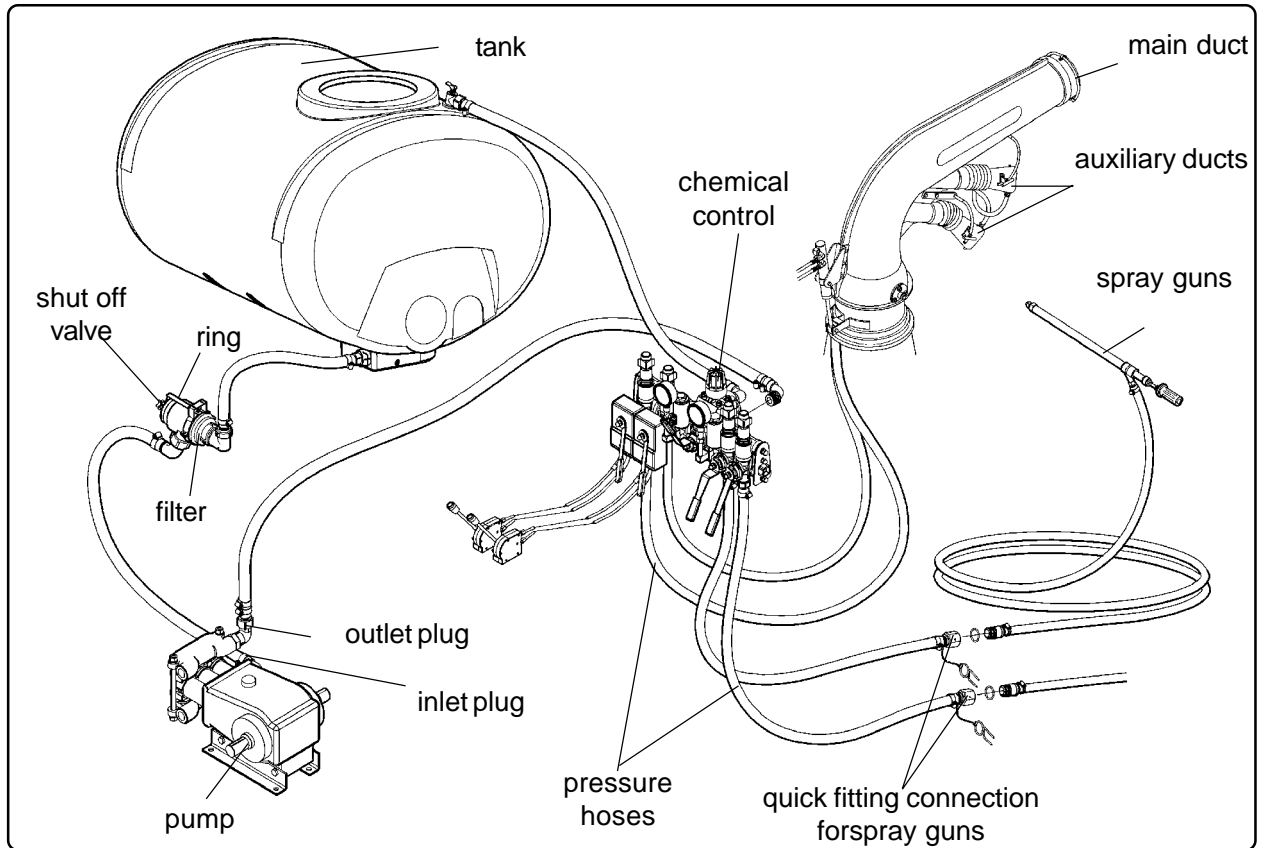

PROCEDURES:

- Empty the tank completely by removing the filter cap and opening the filter shut off valve.
- Disconnect the pressure hose from the pump or remove the outlet plug from the valve cover.
- Run the sprayer for about 30 seconds at half speed.

NOTE: To avoid damage, do not run the sprayer over the recommended time.

- Assemble the components again in their correct place.
- Repeat this operation at the end of each daily spraying job during the winter to avoid problems in future applications.

MAINTENANCE

TROUBLE-SHOOTING

COMPONENTES:

- Tank
- Main filter
- Chemical control
- Pump
- Pressure hoses
- Return hose
- Nozzles

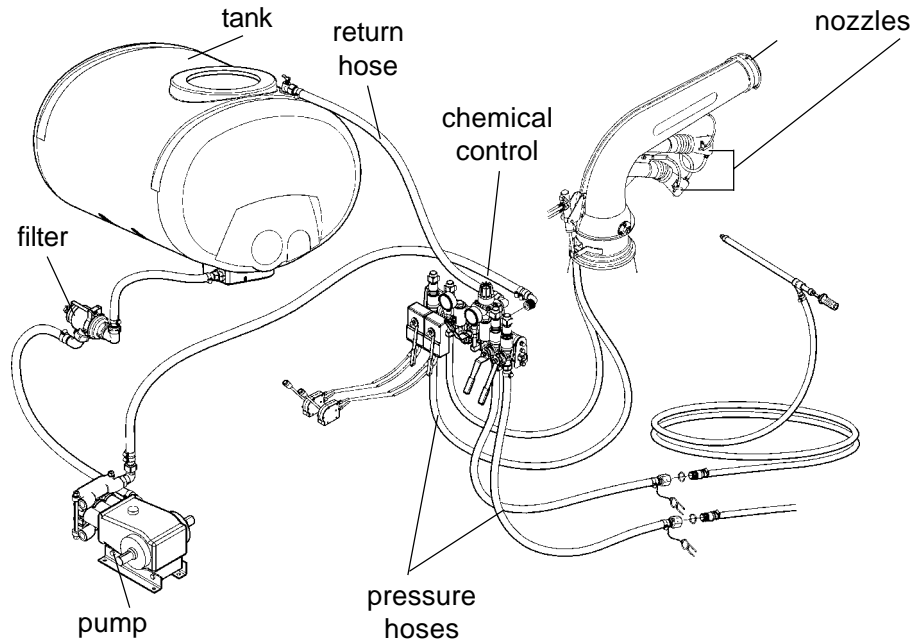

PROBLEMS - CAUSES - SOLUTIONS

Whenever Jacto sprayers equipped with piston pumps present problems, try to classify them in one of the following four groups.

a) LACK OF SUCTION AND PUMPING CAPACITY

- No liquid flow through the nozzles.
- No return to the tank.
- Pressure gauge does not indicate pressure.

b) PRESSURE DEFICIENCY (PARTIAL LACK OF PRESSURE)

- Desired pressure is not attained.
- Specified nozzle spraying angle is not attained.
- Pressure gauge shows lower pressure.

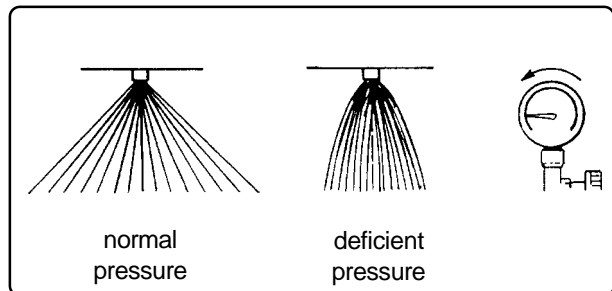

c) PRESSURE OSCILLATION

- The pressure gauge needle oscillates.
- The nozzle spray angle oscillates.

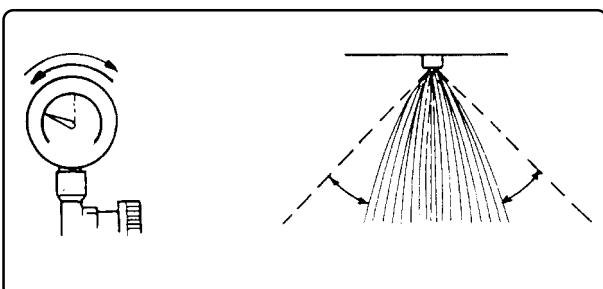

d) INTERMITTENT PRESSURE

- The pressure gauge needle vibrates with intensity.
- The pressure hoses vibrate with intensity.
- The nozzles spray angle varies.

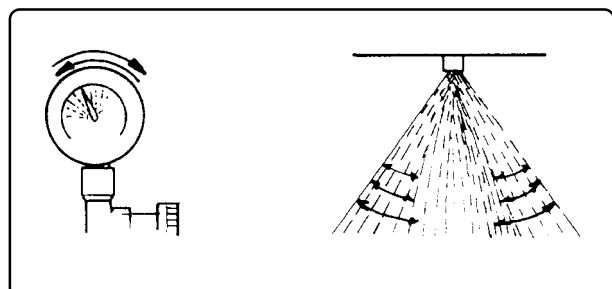

MAINTENANCE

TROUBLE-SHOOTING

a - LACK OF SUCTION AND PUMPING CAPACITY

PROBABLECAUSES	SOLUTIONS
1- PTO not turning.	The sprayer should be run with 540 rpm at PTO. Check visually whether the pump is being run.
2- Lack of water in the tank.	To run the hydraulic system, it is necessary to contain a minimum quantity of liquid, otherwise there will be no pressure.
3- Filter shut off valve closed.	When the pump runs, liquid will pass through the valve even in the closed position, however it will be insufficient. Open it.
4- Dirty filter.	Impurities in the filter prevent a free liquid flow. Clean the filter whenever filling the tank, or with more frequency depending on the quality of the water and the type of product applied.
5- Obstruction in the intake hoses.	Check whether the hose connecting the filter to the pump is twisted. Check whether there is any obstruction in the hoses from tank to filter. Fill up the tank with water, open the valve and verify if it flows freely.
6- Air in the system.	Check the filter packing ring. The filter should not leak.
7- Insufficient pump suction.	Remove the cover of the suction valves. Check the condition of the valves and replace them if necessary.

b - PRESSURE DEFICIENCY

PROBABLECAUSES	SOLUTIONS						
1- Low PTO rpm.	The proper PTO rotation is 540 rpm.						
2- Filter shut off valve closed.	When the pumps runs, liquid will pass through the valve even in the closed position, however flow will be insufficient.						
3- Filter partially obstructed.	The filter should be clean to allow free liquid flow.						
4- Intake hose partially obstructed.	A deficient pump will cause depressurization. Check whether the hose connecting the filter to the pump is twisted. Verify whether there is any obstruction in the hoses connecting the tank to the filter. Fill the tank with water, open the valve and observe if it flows freely.						
5- Air in the system.	Check the connections and the o'rings of the tank outlet and the pump inlet.						
6- Pressure regulator.	Check the valve and valve seat.						
7- Worn nozzles.	Check whether the nozzle flow is within the recommended guidelines. Replace the nozzles when the flow rate exceeds 20% of the specified. Use only nozzles recommended by the sprayer manufacturer.						
8- Pump with lower flow rate.	Disconnect the pressure hose from the control valve. Run the sprayer at 540 rpm. Collect water for one minute and measure. The volume collected should approximate this shown below for each pump model: <table style="width: 100%; border: none;"> <tr> <td style="width: 50%;">JP - 402 = 10 gpm</td> <td style="width: 50%;">JP - 75 = 20 gpm</td> </tr> <tr> <td>JP - 42 = 11 gpm</td> <td>JP - 100 = 26 gpm</td> </tr> <tr> <td>JP - 50 = 13 gpm</td> <td>JP - 150 = 40 gpm</td> </tr> </table>	JP - 402 = 10 gpm	JP - 75 = 20 gpm	JP - 42 = 11 gpm	JP - 100 = 26 gpm	JP - 50 = 13 gpm	JP - 150 = 40 gpm
JP - 402 = 10 gpm	JP - 75 = 20 gpm						
JP - 42 = 11 gpm	JP - 100 = 26 gpm						
JP - 50 = 13 gpm	JP - 150 = 40 gpm						

MAINTENANCE

TROUBLE-SHOOTING

c - PRESSURE OSCILLATION

PROBABLECAUSES	SOLUTIONS
1- Loose belts.	Check belt tension and tighten if necessary.
2- Air in the intaken system.	Check for damaged hoses, filter packing rings, etc., and repair if necessary.
3- Pressure regulator.	Check the regulator components and clean or replace them if necessary.

d - INTERMITTENT PRESSURE

PROBABLECAUSES	SOLUTIONS
1- Filter shut off valve close.	When the pumps runs, liquid will pass through the valve even in the closed position, however flow will be insufficient.
2- Pump valve deficiency.	Valve with sealing deficiency or stuck due to impurities.
3- Head with an internal hole.	Reaplace the head.

GENERAL CARE

HANDLING SPRAYERS AND AGROCHEMICALS

We warn the owners and users that the UNREASONABLE USE of this sprayer and chemicals it applies may cause damage to people, properties, animals and environment.

Read carefully and understand thoroughly this manual and the recommendations of the chemicals manufacturers.

Follow strictly the instructions for proper use of this sprayer and chemicals to ensure more safety and efficiency when spraying your crops.

AFTER SPRAYING

ATTENTION: Avoid leaving chemical mixture residues in the tank. For the last pass, prepare the chemical solution in enough quantity to spray the remaining of the crop.

-Empty completely the tank and wash thoroughly the sprayer in a proper decontamination place.

-Wash the inside and outside of the sprayer with clean water and detergent.

- Disassemble and clean each nozzle assembly with fine brush, water jet or compressed air.

-Dry, lubricate and store the sprayer in a dry and covered place.

-Repaint the damaged metallic parts to prevent corrosion.

-Spray the mettalic parts with lubricating oil to prevent corrosion.

-Take off the individual protective clothing and wash it separately from other clothes.

DANGER
SAFETY OBSERVATION
OPERATING THIS SPRAYER WITHOUT FOLLOWING THE INSTRUCTIONS
MAY RESULT IN SERIOUS INJURY OR DEATH.

STATEMENT OF LIMITED WARRANTY

MÁQUINAS AGRÍCOLAS JACTO S.A. warrants the equipment described herein and agrees to repair or replace parts and components which, under normal operation and wear, following the technical recommendations, show DEFECTS IN MATERIAL OR WORKMANSHIP.

WARRANTY PERIOD:

- One (1) year from the purchase date by the original retail purchaser.

WARRANTY APPLICATION:

Jacto or its authorized representative shall honor this warranty, if any part or component shows confirmed defect in workmanship.

IT SHALL BE UNDERSTOOD THAT THE REPLACEMENT OF COMPLETE COMPONENTS SUCH AS PUMPS, CONTROL VALVES, ENGINES, TRANSMISSIONS, HYDRAULIC PISTONS AND SIMILAR ONES SHALL ONLY BE PERFORMED IN CASE THAT THE DEFECT CANNOT BE REPAIRED BY REPLACING PARTS AND/OR PIECES OF THE COMPONENT.

THIS WARRANTY IS NULL AND VOID IF:

- Equipment is not used in accordance with the INSTRUCTION MANUAL, overwork or accidents.
- Improper preventive maintenance or performed by unauthorized people.
- Modification of the equipment in any way from the original design.
- Change, damage, or loss of the product identification plate.
- Utilization of parts and components not supplied by JACTO.

PRODUCT REGISTRATION CARD MUST BE COMPLETED BY THE ORIGINAL RETAIL PURCHASER, AND RETURNED TO JACTO DEALER WITHIN 30 DAYS OF PURCHASE DATE.

WARRANTY EXCLUSIONS:

- Parts considered as normal maintenance such as: filtering elements, belts, hoses, nozzles, pistons, pressure gauges, as well as usual maintenance, adjustments, retightening, lubrication and painting.
- Parts which show wear or tear due to use, UNLESS THEY SHOW DEFECTS IN WORKMANSHIP, ASSEMBLY OR MATERIAL.
- Hydraulic, lubricating oils and grease.
- Injuries of personal or material nature to the user, owner, or third parties.
- Additional charges resulting from paralyzation and repair of the equipment.
- Freight charges, pick up and delivery charges.
- Damages of any nature resulting from action of gases or liquids used in the equipment.

GENERAL INFORMATION:

- Defective parts replaced under warranty period shall be property of JACTO.
- Eventual delays in performing services do not confer to the owner the right to indemnity or to extension of the warranty period.
- JACTO reserves the right to change its products or to interrupt manufacturing the equipment.
- THIS LIMITED WARRANTY shall be understood by its expressed terms, and no one in anyway subject to JACTO shall be authorized to modify or amplify the conditions prescribed herein.
- In case of need for warranty request, call for the authorized dealer supplying all information required for a prompt compliance. Do not forget the identification of the equipment, total hours of work, and the noticed defect.

FOR THIS WARRANTY TO BECOME EFFECTIVE THE PRODUCT REGISTRATION CARD FOUND IN THE INSTRUCTION MANUAL MUST BE FILLED IN AND RETURNED TO YOUR JACTO DEALER. THIS CARD MUST BE SIGNED BY THE ORIGINAL RETAIL PURCHASER, INDICATING THAT HE HAS READ AND UNDERSTOOD ALL SAFETY AND OPERATIONAL INSTRUCTIONS IN THE MANUAL. FURTHER THE RETAILING DEALER HAS EXPLAINED TO THE ORIGINAL RETAIL PURCHASER ALL SAFETY INSTRUCTIONS. IN NO CASE WILL WARRANTY BE SUPPLIED UNTIL THIS CARD, PROPERLY COMPLETED AND SIGNED, IS ON FILE WITH JACTO RETAILING DEALER.



PRODUCT REGISTRATION CARD

INVOICE NUMBER: _____ DATE: ____ / ____ / ____

RETAILING DEALER: _____

PHONE: _____ CITY: _____ STATE: _____

SPRAYER: _____ MODEL: _____

SERIES: _____ SPRAYER No.: _____ PUMP No.: _____

ORIGINAL RETAIL PURCHASER: _____

ADDRESS: _____ PHONE: _____

CITY: _____ STATE: _____

PURCHASE DATE BY THE ORIGINAL RETAIL PURCHASER: ____ / ____ / ____

THE WARRANTY IS IN FORCE AS OF THIS DATE: ____ / ____ / ____

RETAIL PURCHASER SIGNATURE: _____

Original retail purchaser's copy



PRODUCT REGISTRATION CARD

INVOICE NUMBER: _____ DATE: ____ / ____ / ____

RETAILING DEALER: _____

PHONE: _____ CITY: _____ STATE: _____

SPRAYER: _____ MODEL: _____

SERIES: _____ SPRAYER No.: _____ PUMP No.: _____

ORIGINAL RETAIL PURCHASER: _____

ADDRESS: _____ PHONE: _____

CITY: _____ STATE: _____

PURCHASE DATE BY THE ORIGINAL RETAIL PURCHASER: ____ / ____ / ____

THE WARRANTY IS IN FORCE AS OF THIS DATE: ____ / ____ / ____

RETAIL PURCHASER SIGNATURE: _____

**URGENT
RESPOND WITHIN 30 DAYS
FIRST CLASS POSTAGE REQUIRED**