

PH-400 SA

English version - MI-0099

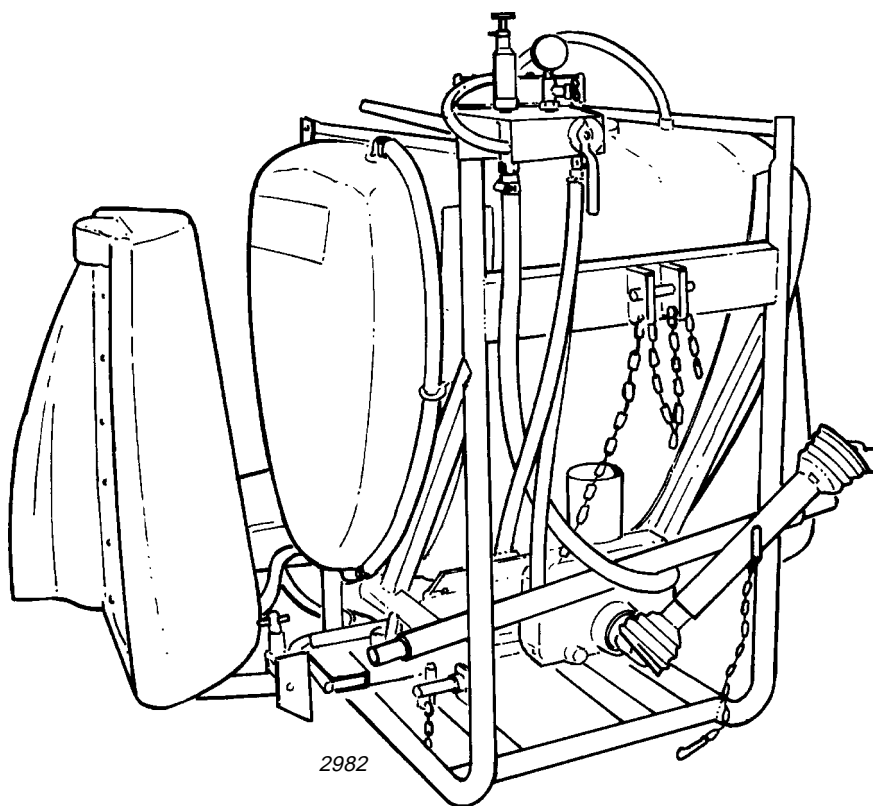

MÁQUINAS AGRÍCOLAS JACTO S.A.

Rua Dr. Luiz Miranda, 1650

17580-000 - Pompéia - SP - Brazil

Tel.: +55 14 452 1811 - Fax: +55 14 452 1306

E-mail: jacto@jacto.com.br

EDITION: 07/99

CODE: 966218

INTRODUCTION

The agrochemicals application is necessary to achieve higher and economical production.

However, as it is a work that can bring risks to the human being, environment and crops, Jacto has always been concerned with the proper use of its spraying machineries in an efficient and safe way.

Therefore, read carefully and understand thoroughly this manual before operating this sprayer and keep it always at hand when handling this sprayer for quick consult in case you are not quite sure of some operation or adjustment.

Should your doubt persist, please contact your Jacto dealer.

MÁQUINAS AGRÍCOLAS JACTO S.A.
CONTRIBUTING TO THE AGRICULTURE DEVELOPMENT.

IDENTIFICATION PLATE

Your sprayer has a plate showing its model and serial number.

This information is very important so that Jacto can keep records of eventual modifications made on the material used and on its construction characteristics.

In requesting replacement parts or maintenance, always specify the model and serial number of your sprayer for prompt and efficient service.

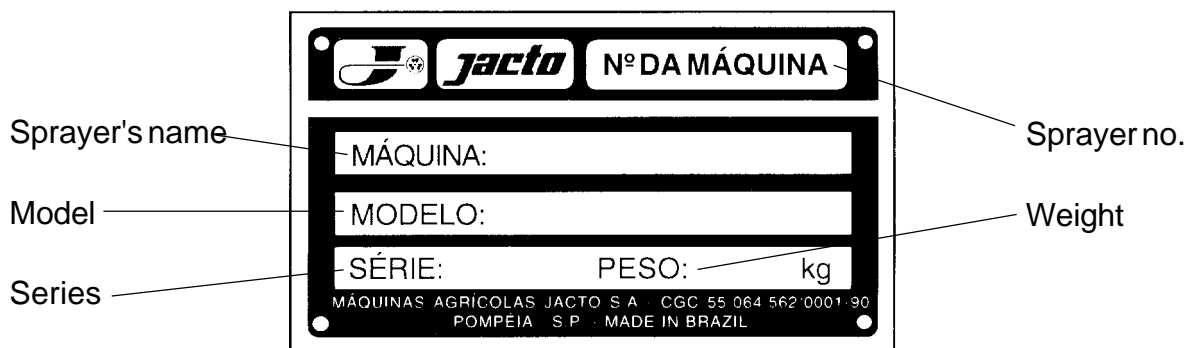

0790

Jacto is trademark registered by Máquinas Agrícolas Jacto S.A.

**JACTO RESERVES THE RIGHT TO CHANGE SPECIFICATIONS AND DESIGN
WITHOUT PRIOR NOTICE.**

TABLE OF CONTENTS

Safety instructions	
Handling agricultural sprayer	05
Handling chemicals	06
Presentation of sprayer	
Technical specifications	07
Main components of sprayer	
Suction filter	08
Pump	08
Pressure regulator	08
Nozzles	09
Low pressure gauge kit	09
PTO shaft	09
In-line filter	09
Protective wings	10
Fill unit	10
Operational procedures	11
Choosing and setting up the tractor	12
Connecting the sprayer	14
Adjusting the spray swath	15
Operation and adjustments	
Spray application technology	17
Nozzles	18
Spraying volume	19
Calibrating the sprayer	20
Diluting the chemicals	22
Maintenance	
Directions	23
Components	23
Lubrication table	24
Lubrication points	24
PTO shaft	25
Decals	26
Winter storage	27
Trouble-shooting	28
General care	
Handling agricultural sprayers and chemicals	31
After spraying	31
Statement of limited warranty	32

SAFETY INSTRUCTIONS

HANDLING AGRICULTURAL SPRAYERS

OWNER/OPERATOR:

This sprayer was carefully designed and built so as to give you the maximum production, saving, easy operation and safety.

Therefore, you or anyone else who is going to operate, maintain and work around this sprayer must read and understand this manual thoroughly in order to be familiar with all the operating and maintenance procedures and safety information related to this sprayer. All accidents can be prevented if all the safety instructions are correctly followed.

Moreover, always keep this manual at hand for quick review in case of doubt.

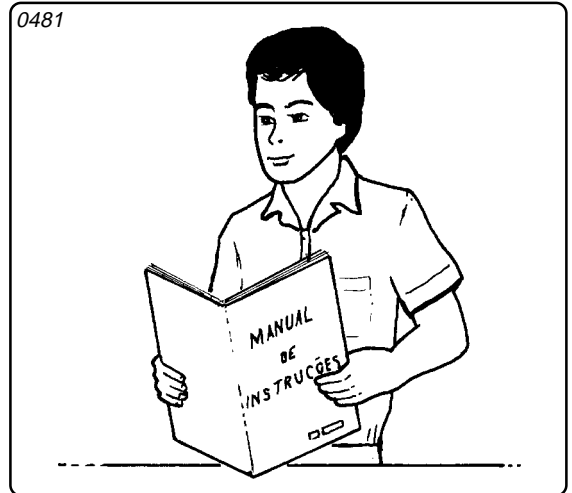

ATTENTION
FAILURE TO FOLLOW THE SAFETY
INSTRUCTIONS PROPERLY WILL RISK YOUR
OWN LIFE AS WELL AS THE LIFE OF PEOPLE
WORKING AND LIVING AROUND YOU.

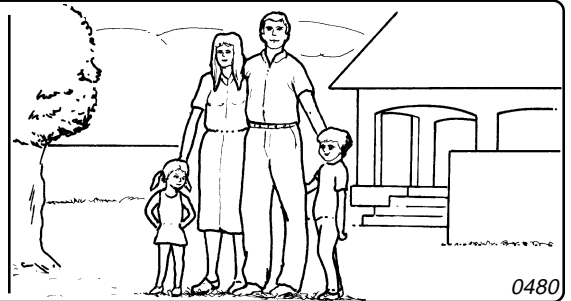

0355



This safety alert symbol identifies important safety messages.

When you see it, be alert to any possibility of personal injury or death.

Keep all the decals on the sprayer and replace them if missing or illegible.

- Before operating this sprayer, read carefully and understand thoroughly this manual.
- Do not allow untrained people to operate this sprayer because this can cause serious injuries or fatal accidents.
- Do not modify this sprayer in any way because this can impair the function and risk your safety.
- Keep away children, aged people and animals while operating, servicing this sprayer and even when the sprayer is stored.
- In the delivery of your sprayer, have your Jacto dealer instruct you on the assembly, operation, maintenance and warranty in detail.
- Keep hands, feet and clothing away from moving parts.
- Never use loose clothing or mittens while working around the sprayer.
- Do not travel at high speeds.
- Always stop tractor engine, disengage the PTO and wait for all moving parts to stop before servicing, adjusting or repairing the sprayer.

ATTENTION: Do not touch PTO shafts, belts, fans or any other moving part while the sprayer is running.

- Only unhitch the sprayer on firm and level ground.
- Keep your sprayer in thorough repair.

SAFETY INSTRUCTIONS

HANDLING CHEMICALS

Chemical products are classified in four categories of toxicity. According to their toxicity level, there is a special recommendation of appropriate protective clothing.

As your safety concerns first, we list below all the protective clothing recommended for handling chemical products of the category 1 which includes high toxicity level chemicals.

This way, all the possibilities of serious illness and death are eliminated.

INDIVIDUAL PROTECTIVE CLOTHING FOR HANDLING CHEMICALS

- Long-sleeved working clothes
- Impermeable apron or coverall
- Impermeable gloves
- Impermeable wide-brimmed hat
- Boots
- Special protective masks equipped with appropriate filters for each type of product

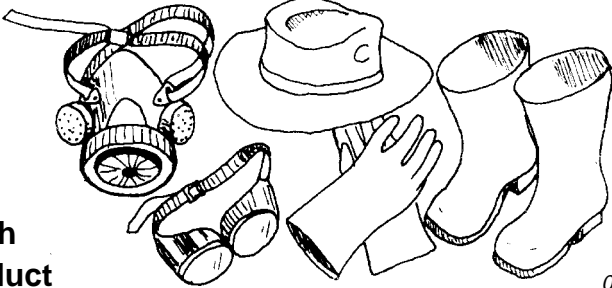

0478

CHEMICAL PRODUCTS CLASSIFICATION

0479 	TOXICITY LEVEL		LABEL COLOR ON CHEMICALS CONTAINER
	I	HIGH	RED
	II	MODERATE	YELLOW
	III	LOW	BLUE
	IV	LIGHT	GREEN

DIRECTIONS

- Read and follow all instructions on the chemicals manufacturer's label.
- Keep the chemical products closed and in a dry and ventilated place.
- Use the chemical products in agriculture only.
- Keep away children, untrained people and animals.
- Handle the chemicals following recommendations of a technician.
- Always handle chemicals in a ventilated place and equipped with individual protective equipment.
- Use the application rate as per instructions on the labels.
- Do not make spray applications in the wind or hot weather.
- Do not drink, eat or smoke while spraying or handling chemicals.
- Keep children, untrained people and animals away from the application areas.
- Never blow through nozzles strainers, valves or pipelines by mouth.
- Do not store or transport chemical products together with food, medicines, people, animals.
- Make sure rivers, lakes, etc. will not be contaminated when washing out the sprayer.
- After spraying, take off all protective clothing and take a shower.
- In case of intoxication, go see a doctor immediately and show him the chemical products label.
- Never medicine an unconscious person through mouth.
- **Do not re-use the chemical products containers for other purposes. Consult an agronomist on how to discard empty containers of chemical products.**

PRESENTATION OF SPRAYER

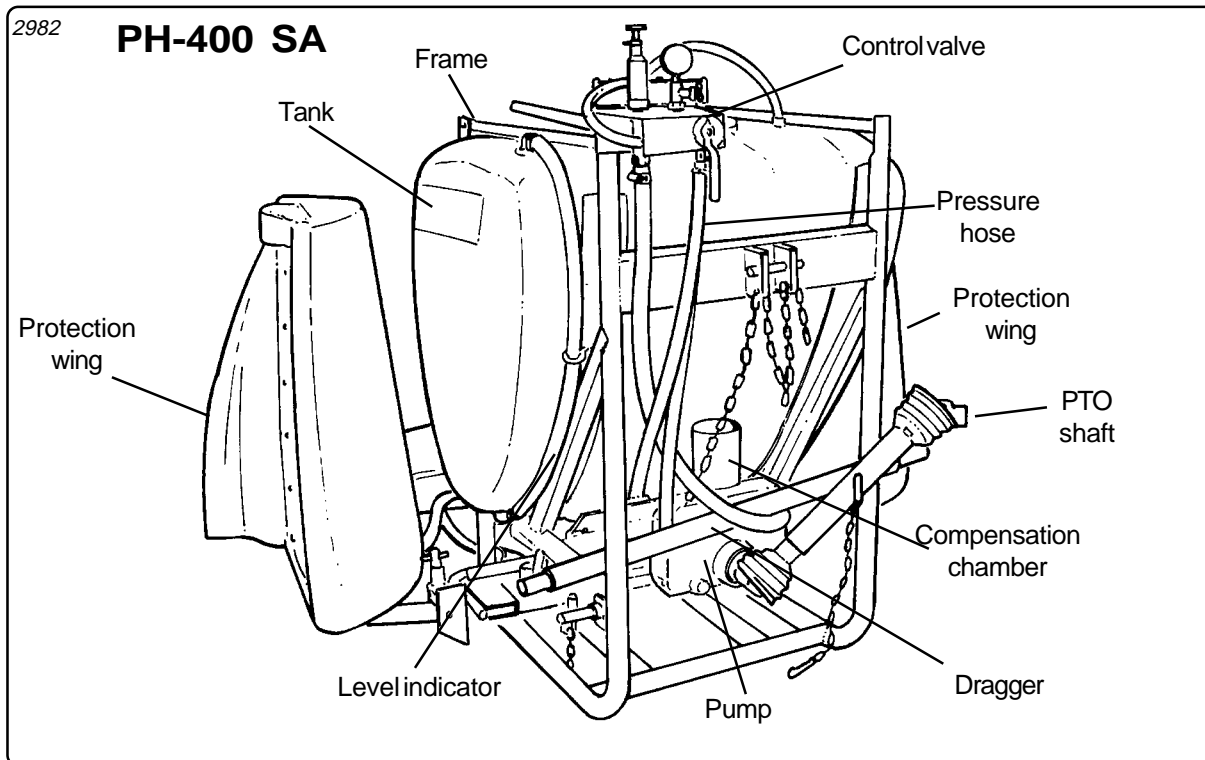

TECHNICAL SPECIFICATIONS

Length (m)	1.50 (withdrawn central boom)
Width (m)	1.68 (withdrawn side wings)
Height (m)	1.43
Weight (kg)	210
Tank	
- Capacity (L)	400
- Material	Polyethylene
Filter	
- Model	FVS-100
- Mesh	80
In-line filter (Qty.)	02
Pump	
- Model	JP-402
- Capacity (L/min.)	38
- Maximum pressure (kgf/cm ² - psi)	10.5 (150)
- Power consumption (HP)	1.1 (at 10.5 kgf/cm ² - 150 psi)
Pressure gauge	
- Model	With extended scale
Nozzles installed	
- Central	3 - DEF-015 (green)
- Lateral	2 - DEF-015 (green)
- Maximum pressure (kgf/cm ² - psi)	2 (30)
Spray swath (m)	
- Total (m)	From 2.90 to 3.62
Level indicator	Hose attached to the tank
Agitator	Hydraulic (return)
Filler unit	
- Model	EJ-150
Working speed (km/h)	Up to 6 km/h

MAIN COMPONENTS OF SPRAYER

SUCTION FILTER

Located between the tank and pump, the suction filter is specifically designed to prevent dirt or impurities from reaching the pump.

It has an easy-to-reach shut off valve which stops the liquid flow to allow filter cleaning, filtering elements changing and/or pump maintenance.

This shut off valve must remain open while the sprayer is running. If it remains closed, you will hear an unusual noise in the pump.

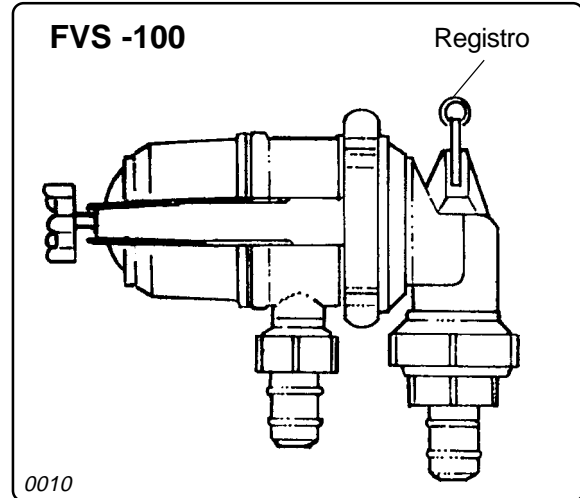

PUMP

The pumps installed on Jacto sprayers are produced by Jacto, and they have flow rates ranging from 38 to 300 liters per minute.

PUMP MODEL	CAPACITY (L/min at 540 rpm)	MAXIMUM WORKING PRESSURE	
		psi	kgf/cm ²
JP - 401	38	300	21
JP - 402	38	300	21
JP - 42	42	300	21
JP - 75	75	500	35
JP - 100	100	500	35
JP - 150	150	500	35
JP - 300	300	500	35

With capacity of 38 L/min at 540 rpm, the JP-402 pump runs under pressure of up to 21 kgf/cm² (300 psi). NOTE: on this sprayer, the control valve limits the pressure to 7 kgf/cm².

The sleeves are made of ceramic, a material that ensures efficient application and provides more durability against chemical abrasion.

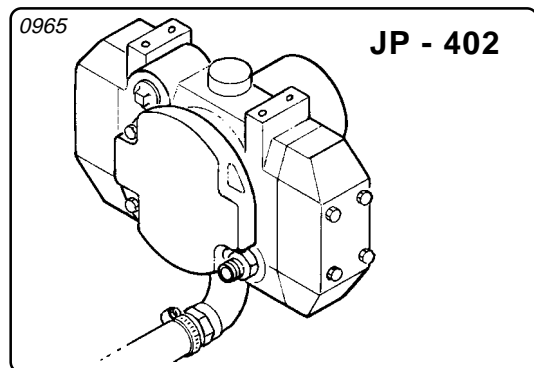

PRESSURE REGULATOR

The pressure regulator on the PH-400 SA sprayer provides adjustments from 0 to 7 kgf/cm² (0 to 100 psi).

For longer life of the pressure gauge, after calibrating the sprayer, set the lever to turn off the spray, so the pressure gauge's hand drops to zero.

Then, close the pressure gauge valve.

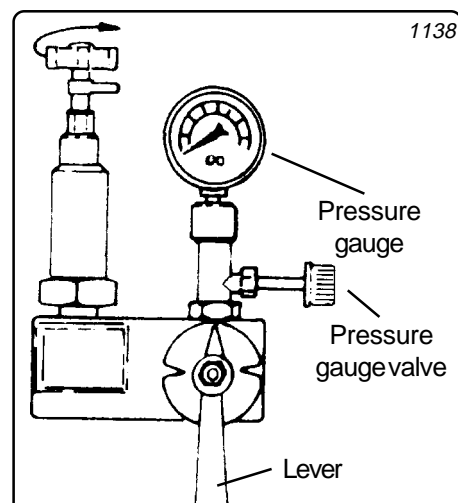

MAIN COMPONENTS OF SPRAYER

SPRAY NOZZLES

SINGLE NONDRIP NOZZLE HOLDER

The job of the nozzles is to generate droplets and distribute them uniformly over the surface being sprayed.

Flow, angle and droplet sizes vary according to working pressure. Operating with pressure over that recommended by the manufacturer will decrease the nozzles' life.

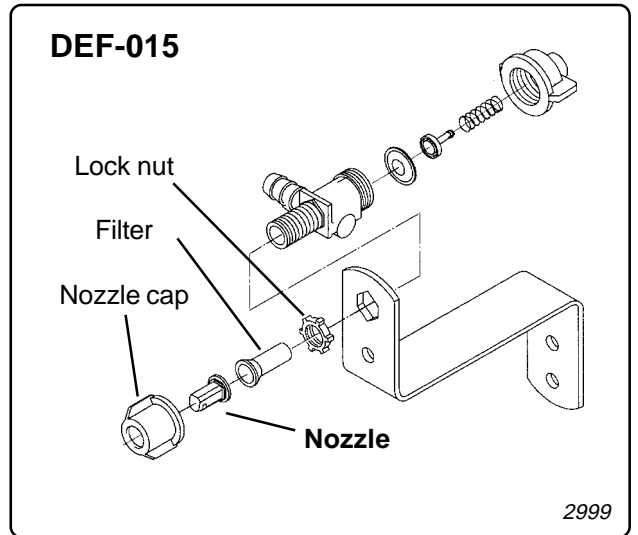

PTO SHAFT

It has plastic guards along all its parts to provide more safety to the operator. These guards prevent the rotating parts from contacting the operator and his clothes, as well as plants. Do not remove them.

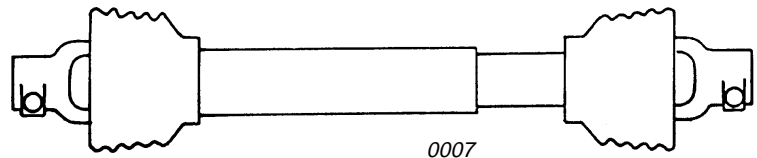

IN-LINE FILTER

This component is mounted in the pressure line of the sprayer and must not work at pressure above 150 psi.

This filter has 80 mesh and optimizes the filtration to the nozzles.

TECHNICAL SPECIFICATIONS

Maximum working pressure	150 psi
Filtering element mesh	80
Hose fitting	ø 1/2"

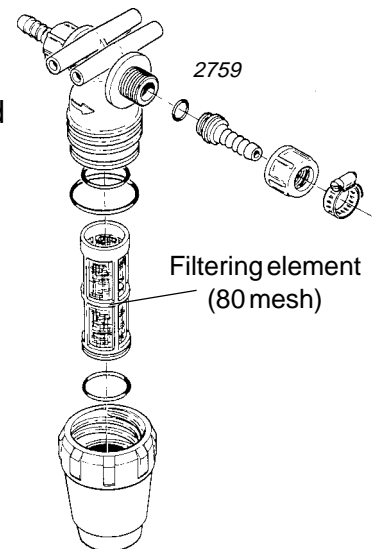

LOW PRESSURE GAUGE KIT (OPTIONAL)

The low pressure gauge kit was designed for checking the actual pressure on nozzles.

It can be installed on the sprayers assembled with both universal nozzle caps and fittings and complex nozzle holders, such as double and quadruple units.

The maximum pressure of this kit is 100 psi. However, the pressure regulators of sprayers can easily reach above 100 psi, which can damage the pressure gauge. To ensure longer life of the pressure gauge, close the valve after regulating the sprayer.

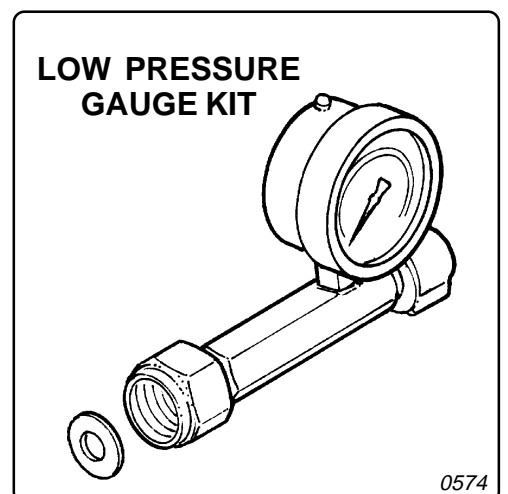

MAIN COMPONENTS OF SPRAYER

PROTECTIVE WINGS

These protective wings allow to apply herbicides directly to the weeds, without chemicals waste and with total protection to the trees trunk, leaves and branches.

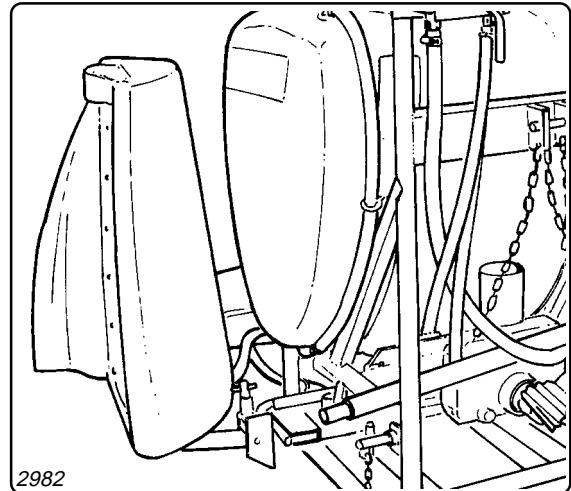

EJ-150 FILLER UNIT

- Put 20 liters of water in the tank.
- Disconnect the pressure hose (1) from the control valve and connect it with the fill unit hose (2).
- Put the fill unit (3) in the water source and the end of its discharge hose (4) into the tank mouth.
- Run the PTO at 540 rpm.
- After finishing the filling operation, connect the pressure hose (1) with the control valve again.
- Put the chemical in the tank and run the sprayer for 5 minutes before starting to spray, so the chemical mixture will become homogeneous.

ATTENTION: In case of wettable powders, stop the pump only after the tank is empty to avoid decantation.

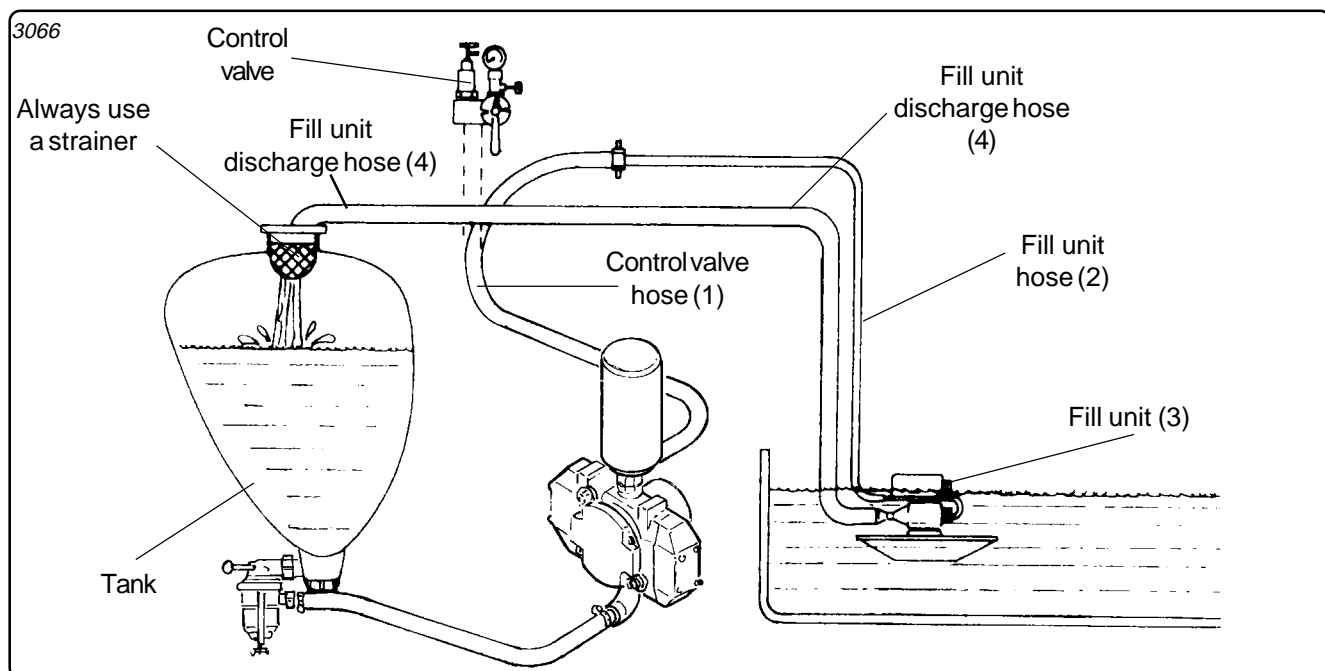

***PROTECT THE ENVIRONMENT
AND ENSURE A HEALTHY LIFE.***

ATTENTION

THE SPRAYER FILLING OPERATION MUST BE MADE IN PLACES DESIGNED OR APPROPRIATE FOR THIS PURPOSE OR BY MEANS OF APPROPRIATE VEHICLES (TRUCKS, TRAILERS, ETC.). NEVER COLLECT WATER FROM RIVERS, LAKES, DAMS, STREAMS, BROOKS, ETC. USING THE SPRAYER'S RETURN SYSTEM.

OPERATIONAL PROCEDURES

Stage	Procedure	Sprayer type	
		Trailer	3 point
Spraying	Use individual protective clothing	X	X
	Do not work at high speeds	X	X
	Do not spray against the wind	X	X
	Do not travel with booms lifted or unlocked	X	X
	Take care with electricity supply cables	X	X
	Do not eat, drink or smoke while spraying	X	X
	After spraying, dispose of all protective clothing and take a shower	X	X
Receiving the sprayer	Check if all components are intact	X	X
	Check the components of accessories box	X	X
	Require trained person to instruct about assembling, operating and servicing components and accessories ...	X	X
Using the sprayer for the first time	Check if the hitch pin is original	X	-
	Check if the three-point hitch pins are original	-	X
	Check if the hitch pins have cotter pins	X	X
	Check the overlaps of the PTO shaft	X	X
	Remove the tractor's drawbar	-	X
	Raise to the highest the tractor's hydraulic arms	X	X
	Adjust the control valve position to avoid impacts while turning	X	-
	Check if the grease fittings are filled	X	X
	Check if the oil is on the level on the components	X	X
	Calibrate the tires	X	-
Retighten the tank nuts and lug nuts	X	-	
Whenever filling the tank	Clean the suction or line filters	X	X
	Clean nozzles and their strainers	X	X
Every day or every 10 hours	Clean nozzles, strainers and filters	X	X
	Check the grease fittings and joint pins	X	X
	Check the oil level on the pumps and gear box	X	X
	Wash the inside and outside of the sprayer	X	X
	Check for damage on the paint and repaint	X	X
	Check for oil leakage and stop it	X	X
First 30 hours	Change for the first time the pump oil	X	X
	Retighten the bolts on the tank, axle and wheels	X	-
Every 100 hours	Change the oil of the pump and gearbox	X	X
	Tighten the belts	X	X
	Clean and check the pressure regulator components	X	X
	Clean the inside and outside of the sprayer, and paint the parts subject to corrosion with a mixture of lubricating oil at 80% and diesel oil at 20%	X	X
Every 500 hours or annually	Service the pump	X	X
	Change hydraulic oil	X	-
	Change the oil of the gearbox	X	X
	Retighten the bolts of tank, wheels, axle, etc.	X	-
	Change the grease of the wheel hub	X	-

CHOOSING AND SETTING UP THE TRACTOR

CHOOSING THE TRACTOR CONSIDERING THE HYDRAULIC LIFT SYSTEM CAPACITY

The tractor should have lift capacity above the sum of the sprayer net weight (sprayer with empty tank) plus the weight equivalent to the tank capacity.

PH-400-SA	
Sprayer net weight	210 kg
Tank capacity	400 L (approximately 400 kg)
Tractor recommended	With hydraulic system lift capacity above 565 kg (210 + 400)

ATTENTION

The numbers above refer to this sprayer only.
As for the tractor, please consult its operator's manual.

ADJUSTING PARTS TO MOUNT ON THE TRACTOR'S THREE-POINT SUSPENSION

ATTENTION: The instruction below is an example of what should be done for properly hitching the sprayer on the tractor's three-point suspension. To exemplify we have used the Ford 4600 tractor. However, you should proceed as directed in the operator's manual of your tractor.

TIE ARM OF THE LEFT BAR

To adjust the length of the left lift arm to the proper position, loosen the pin and turn the lower half (2) of the lift arm.

NOTE: The grease fitting (1) should point upward.

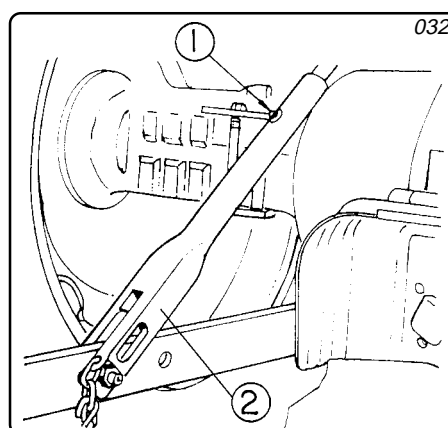

LEVELLING BOX

To adjust the transversal levelling of the sprayer, turn the crank (1) located on the levelling box.

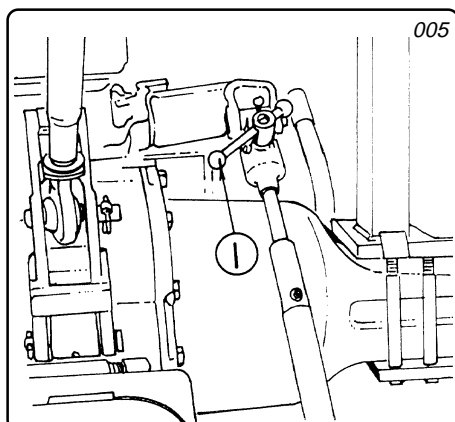

ADJUSTING THE THIRD POINT

Release the lock (1) and turn the sleeve (2) to adjust the length of the third point arm. During transport, fasten the plate of the third point bar to the pin (3) of the frame.

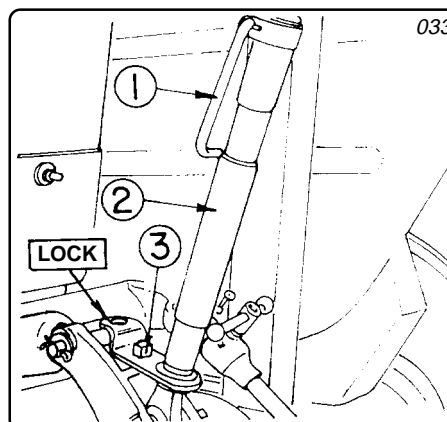

CHOOSING AND SETTING UP THE TRACTOR

THIRD POINT FRAME

The third point frame has two positions (1 and 2) to install the third arm and two positions (3 and 4) to install the frame lower pin.

Thus there are four different positions for this assembly.

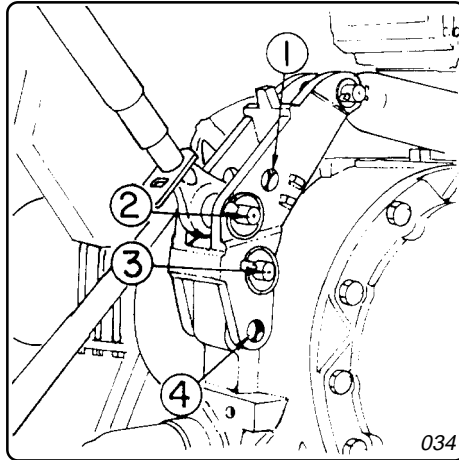

HOLES POSITION

The positions of the holes vary according to the duty to be done.

Third arm's position	Frame	Duty
No. 1	No. 4	Ultra-light
No. 1	No. 3	Light
No. 2	No. 4	Medium
No. 2	No. 3	Heavy

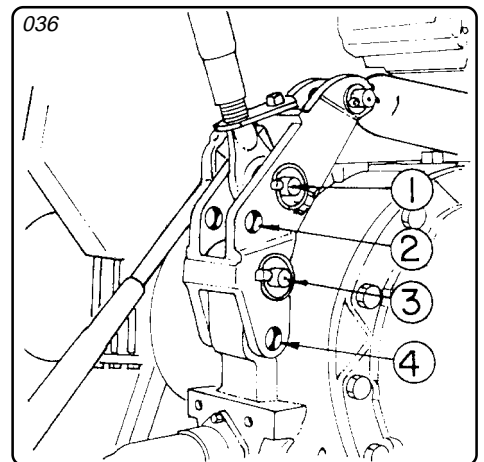

STABILIZING CHAINS

The stabilizing chains should be installed to limit the lateral movement of the sprayer hitched to the three-point system.

These chains should be adjusted according to the boom of the sprayer to be used. To adjust them, relieve the lock nut (1) and turn the adjusting nut (2) as necessary, and retighten the lock nut.

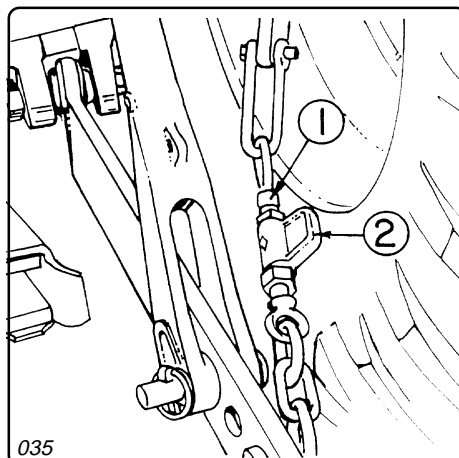

CONNECTING THE SPRAYER

- Remove or set aside the tractor's drawbar.

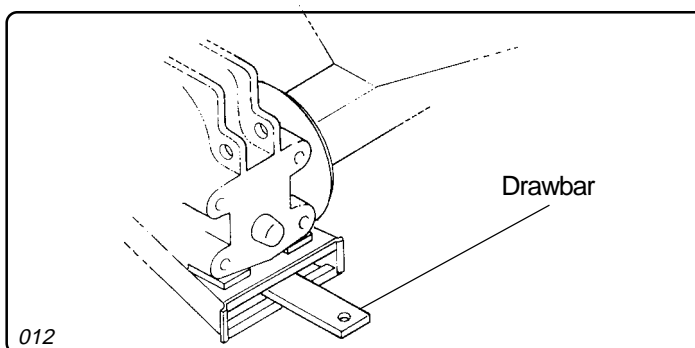

- Mount the sprayer on the tractor three-point suspension and level it as shown in the figure beside.

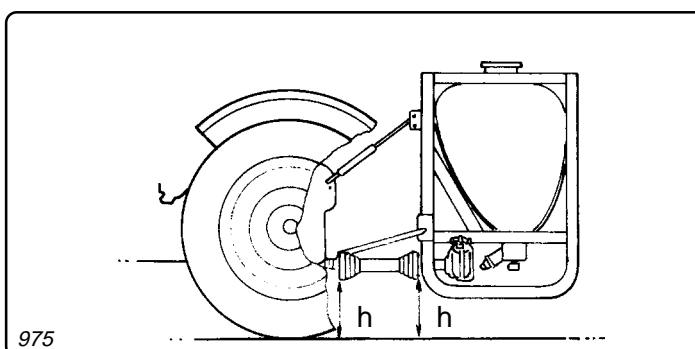

- Adjust the tractor hydraulic lift lever so that the sprayer is not raised too high.

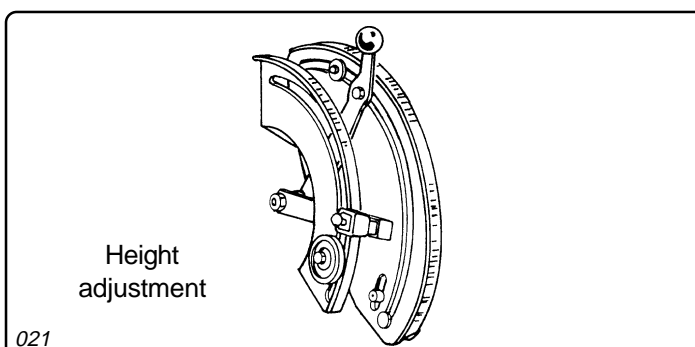

- Adjust the PTO shaft. If necessary, cut the male and female tubes so that, after connecting the sprayer, it has the overlaps recommended in the figure beside.

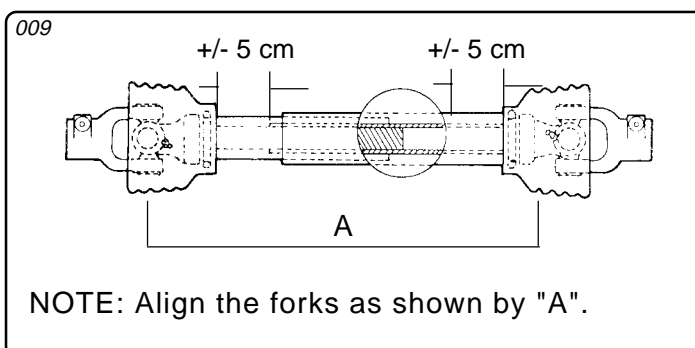

ATTENTION

Before cutting the tubes, check for all possibilities of movement of the sprayer on the lift arms and third point.

Make sure the hitch pins locks are correctly installed.

For instructions in detail, please refer to the section **MAINTENANCE - PTO SHAFT**.

ADJUSTING THE SPRAY SWATH

PROCEDURE

The spray swath of the PH-400-SA adjusts from 1.40 to 3.62 meters.

The application can be central with swath from 1.40 to 1.97 meters.

CENTRAL BOOM ADJUSTMENT

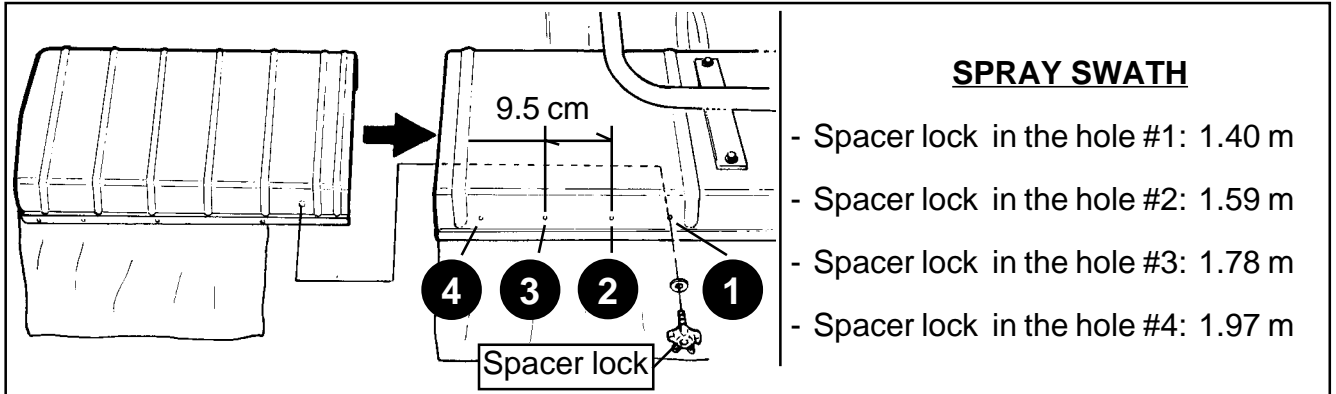

PROTECTIVE WINGS ADJUSTMENTS

- Remove the spacer locks.
- Slide the protective wings (toward the center to narrow the spray swath; toward the side to widen the spray swath). After that, reinstall the spacer locks.

NOTE: There are 5 settings at every 9 cm on either side, and the spray swath can adjust from 2.90 to 3.62 meters.

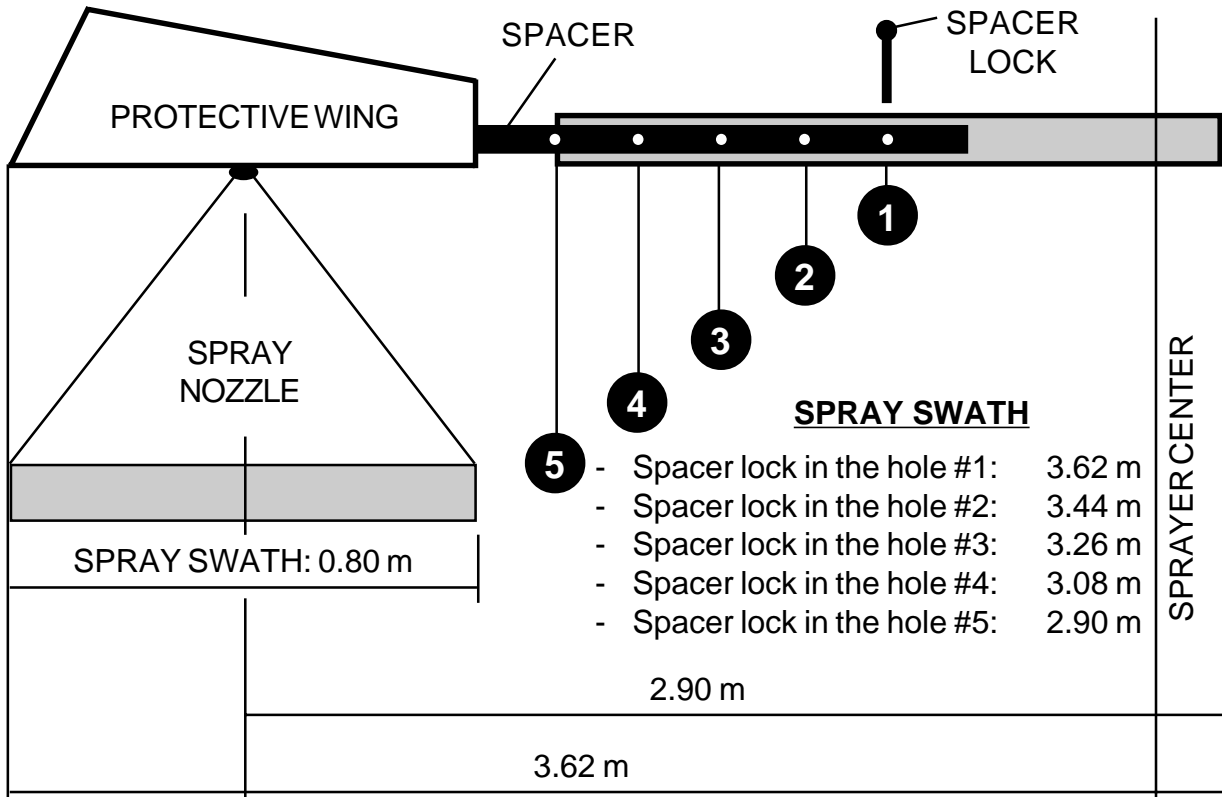

APPLICATION

The protective wings should be positioned parallel to the ground and as low as possible to reduce the effects of wind drift.

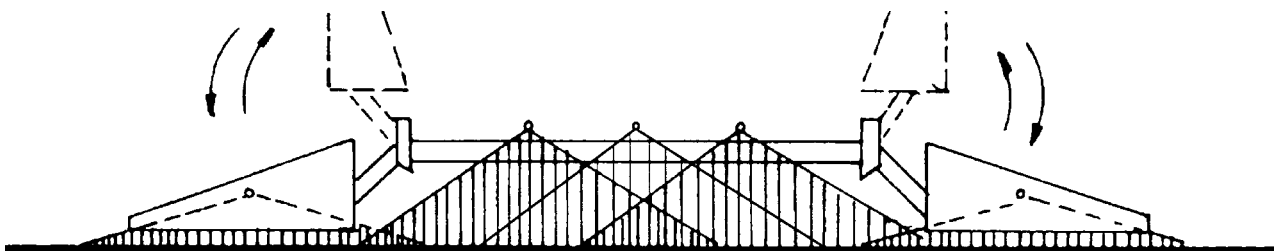

ADJUSTING THE SPRAY SWATH

PROTECTIVE WINGS LOCK

- Release the lock (1) to lower the wings.

The protective wings should be positioned in the vertical only when the sprayer is being transported for refilling the tank or to the spraying area.

ATTENTION: Do not spray with the wings positioned in the vertical.

ADJUSTING THE HEIGHT OF THE WING END

- The leveling of the wings can be adjusted through the screw shown in the figure beside.

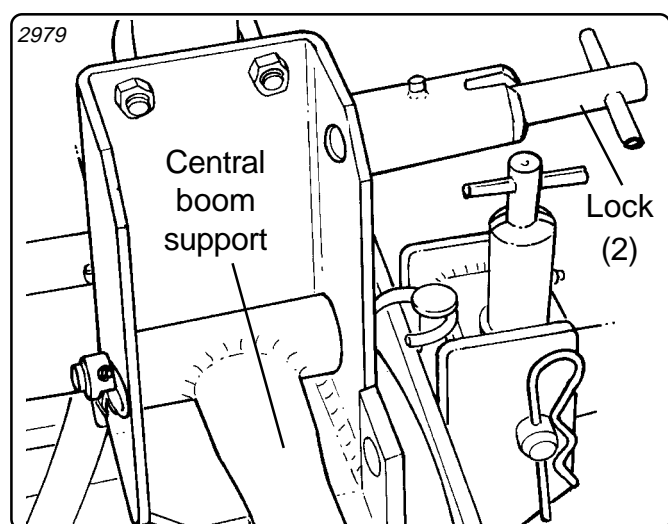
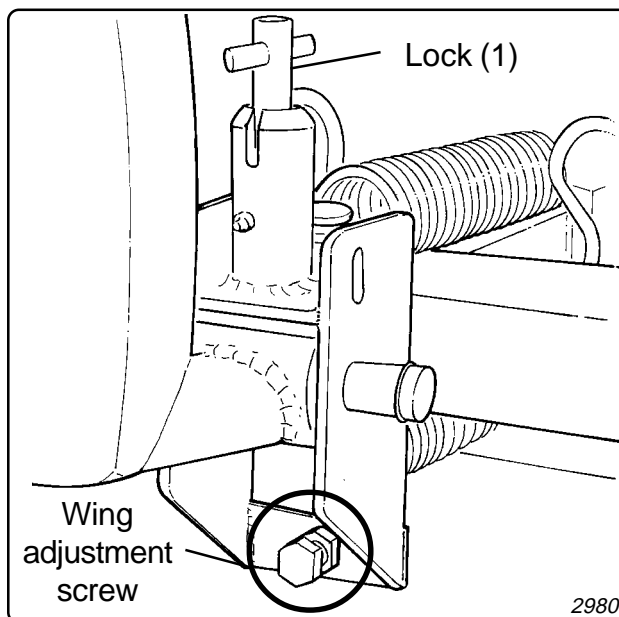

CENTRAL BOOM LOCK

- To set the central boom in the working position, release the lock (2) and pull the boom.

ATTENTION: Do not spray with the central boom in the vertical (transport position).

DRAGGER

The dragger is a metal tube which should be released on the ground during the application.

It is designed to pull down the weeds so as to allow a uniform herbicides distribution.

It adjusts from 1.20 to 2.0 meters through two extensions with 5 settings at every 10 cm toward either side.

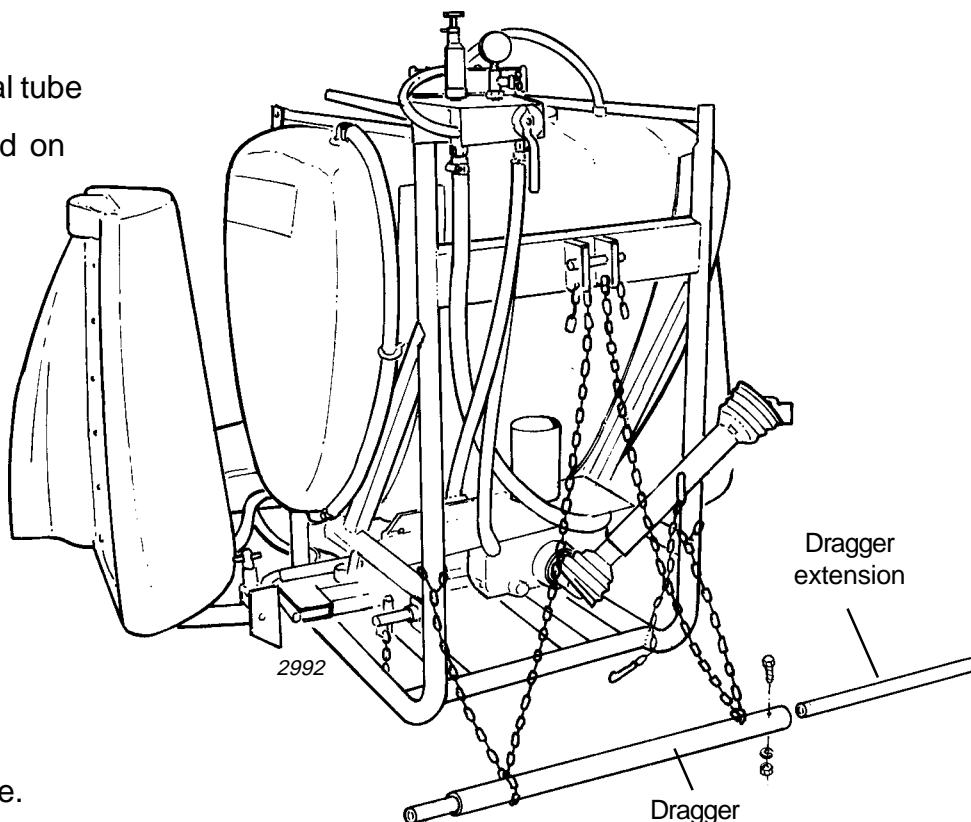

OPERATION AND ADJUSTMENTS

SPRAY APPLICATION TECHNOLOGY

A successful spray application does not depend only on a good sprayer or correct use of the chemicals but also on factors to be determined in the field under specialized orientation.

Among these factors, some concepts should be part of a criterion of evaluation so that positive results may be attained within the pest control program.

- **Ideal time**
- **Safety**
- **Sprayer operational condition**
- **Application rate**
- **Good coverage**
- **Well trained operator**

IDEAL TIME

The ideal time for spraying should be chosen according to the chemical product characteristics, as well as to the field conditions:

- Infestation level of pests, diseases and weeds;
- Infection level of diseases;
- Growing stage of weeds;
- Weather conditions.

SAFETY

When spraying your crops, you must make sure there will be no risk to people, animals and environment. Avoid spraying at hotter times, with humidity below 55% or under windy conditions. **Do not allow the operator to handle chemicals and spraying machinery without the proper individual protective clothing.**

CORRECT APPLICATION RATE

Any type of application requires that the rate be maintained during the whole spraying work. This will be possible when you have a good sprayer properly calibrated.

This calibration can be obtained through practical methods or formulas. Please refer to the section **OPERATION AND ADJUSTMENTS - CALIBRATING THE SPRAYER.**

GOOD COVERAGE

You have a good coverage when the whole target is sprayed with uniform distribution, with no risk to the environment and with good results in the pest control.

The application rate does not have influence on the treatment results. Therefore good coverages can be attained even with different rates, which may vary according to operational and regional factors.

IMPORTANT!

READ CAREFULLY AND FOLLOW STRICTLY THE INSTRUCTIONS ON THE CHEMICALS MANUFACTURER'S LABEL.

ALWAYS FOLLOW DIRECTIONS OF A TECHNICIAN WHEN HANDLING AND APPLYING CHEMICALS.

ALWAYS MAKE SURE THE SPRAYER IS IN GOOD OPERATIONAL CONDITIONS BEFORE STARTING THE SPRAYING JOB AND EMPLOY A WELL TRAINED OPERATOR.

OPERATION AND ADJUSTMENTS

KEMATAL NOZZLES - SERIES DEF

DEFLECTOR EVEN FAN SPRAY

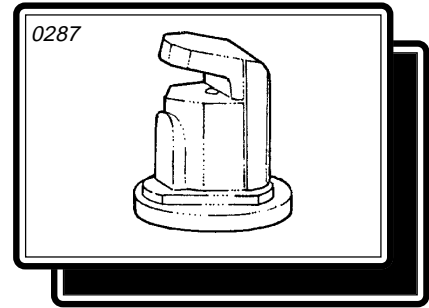

TECHNICAL CHARACTERISTICS

SPRAY PATTERN JATO PLANO (LEQUE)
 SPRAY ANGLE SEE THE TABLE
 MATERIAL **KEMATAL**
 FLOWRATE IDENTIFICATION NOZZLE COLOR AND DESCRIPTION (ISO STANDARD)

These nozzles are made of KEMATAL, a highly resistant and stable polymeric material.
 They are recommended for spray applications requiring large droplets to minimize the drift caused by wind.

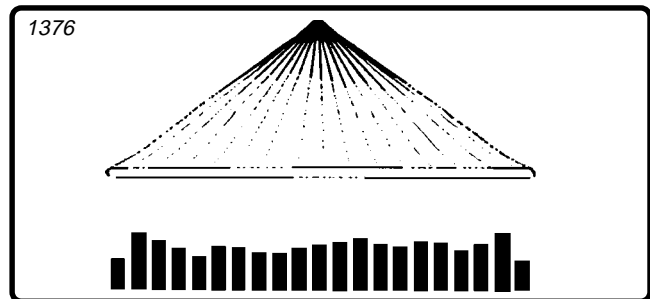
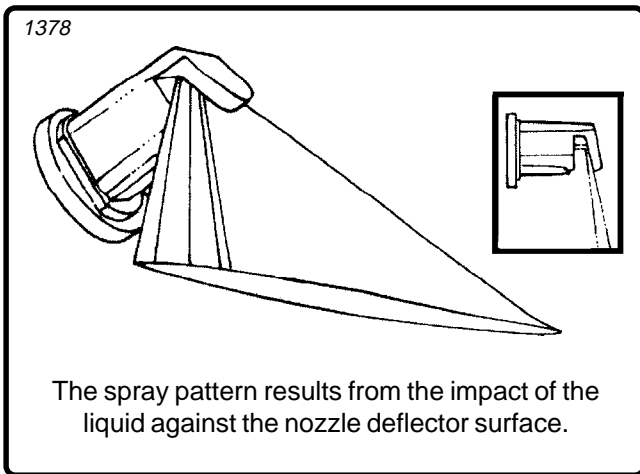

The spray formed has wide angles, even fan and narrow pattern with pressures around 15 psi. The nozzles of the Series DEF produce a relatively uniform spray distribution, with peaks at the edges.

FLOW RATE TABLE

Nozzle		Pressure (psi)			
		15	20	25	30
Color	Description	Flow rate (L/min)			
Orange	DEF-01 D/0.23/1	0.25	0.29	0.31	0.34
Green	DEF-015 D/0.35/1	0.41	0.47	0.51	0.56
Yellow	DEF-02 D/0.46/1	0.47	0.54	0.61	0.66
Red	DEF-04 D/0.92/1	0.95	1.04	1.18	1.28
Brown	DEF-05 D/1.15/1	1.20	1.34	1.54	1.63
Gray	DEF-06 D/1.39/1	1.54	1.73	1.95	2.07
White	DEF-08 D/1.85/1	1.92	2.15	2.41	2.60
Lilac	DEF-105 D/2.43/1	2.50	2.60	2.98	3.24

NOZZLES STRAINERS: Orange and green nozzles: 80 mesh; other nozzles: 50 mesh.

ORDERING

Nozzle color	Orange	Green	Yellow	Red	Brown	Gray	White	Lilac
Nozzle description	DEF-01	DEF-015	DEF-02	DEF-04	DEF-05	DEF-06	DEF-08	DEF-105
Part no.	457366	457374	457382	457390	457408	457416	457424	457432

OPERATION AND ADJUSTMENTS

SPRAYING VOLUME (L/ha) [Spray swath: 2.90 meters]

NOZZLE	Pressure (psi)	Total flow rate (L/min) <i>[5 nozzles]</i>	WORKING SPEED (km/h)				
			2	3	4	5	6
			SPRAYING VOLUME (L/ha)				
DEFLECTOR DEF - 015 (GREEN)	15	2.05	212.07	141.38	106.03	84.83	70.69
	20	2.35	243.10	162.07	121.55	97.24	81.03
	25	2.55	263.79	175.86	131.90	105.52	87.93
	30	2.80	289.66	193.10	144.83	115.86	96.55

SPRAYING VOLUME (L/ha) [Spray swath: 3.08 meters]

NOZZLE	Pressure (psi)	Total flow rate (L/min) <i>[5 nozzles]</i>	WORKING SPEED (km/h)				
			2	3	4	5	6
			SPRAYING VOLUME (L/ha)				
DEFLECTOR DEF - 015 (GREEN)	15	2.05	199.68	133.12	99.84	79.87	66.56
	20	2.35	228.90	152.60	114.45	91.56	76.30
	25	2.55	248.38	165.58	124.19	99.35	82.79
	30	2.80	272.73	181.82	136.36	109.09	90.91

SPRAYING VOLUME (L/ha) [Spray swath: 3.26 meters]

NOZZLE	Pressure (psi)	Total flow rate (L/min) <i>[5 nozzles]</i>	WORKING SPEED (km/h)				
			2	3	4	5	6
			SPRAYING VOLUME (L/ha)				
DEFLECTOR DEF - 015 (GREEN)	15	2.05	188.65	125.77	94.33	75.46	62.88
	20	2.35	216.26	144.17	108.13	86.50	72.09
	25	2.55	234.66	156.44	117.33	93.87	78.22
	30	2.80	257.67	171.78	128.83	103.07	85.89

SPRWYING VOLUME (L/ha) [Spray swath: 3.44 meters]

NOZZLE	Pressure (psi)	Total flow rate (L/min) <i>[5 nozzles]</i>	WORKING SPEED (km/h)				
			2	3	4	5	6
			SPRAYING VOLUME (L/ha)				
DEFLECTOR DEF - 015 (GREEN)	15	2.05	178.78	119.19	89.39	71.51	59.59
	20	2.35	204.94	136.63	102.47	81.98	68.31
	25	2.55	222.38	148.26	111.19	88.95	74.13
	30	2.80	244.19	162.79	122.09	97.67	81.40

SPRAYING VOLUME (L/ha) [Spray swath: 3.62 meters]

NOZZLE	Pressure (psi)	Total flow rate (L/min) <i>[5 nozzles]</i>	WORKING SPEED (km/h)				
			2	3	4	5	6
			SPRAYING VOLUME (L/ha)				
DEFLECTOR DEF - 015 (GREEN)	15	2.05	169.89	113.26	84.94	67.96	56.63
	20	2.35	194.75	129.83	97.38	77.90	64.92
	25	2.55	211.33	140.88	105.66	84.53	70.44
	30	2.80	232.04	154.70	116.02	92.82	77.35

OPERATION AND ADJUSTMENTS

CALIBRATING THE SPRAYER

The safety of people, animals and environment depends on correct spray applications. Therefore, we list below important operational procedures.

WHEN HANDLING CHEMICALS

- Follow strictly the instructions on the labels.
- Use individual protective clothing recommended.
- Do not eat, drink or smoke.
- Choose a ventilated place.
- Wash with water and soap the parts of the body touched by chemicals.

WHEN OPERATING SPRAYER

- Check for the proper working conditions of the sprayer.
- Do not blow by mouth nozzles, valves or tubes.
- Do not spray against the wind.
- Do not spray at sunny times
- Use individual protective clothing recommended.
- Do not eat, drink or smoke.

REMEMBER!

You are responsible for the success of the application.

CALIBRATING THE SPRAYER

The sprayer can be calibrated through the formula below or through the calibrator bottle as shown in the next page.

CALCULATING THE SPRAY VOLUME

$$V = \frac{F \times 600}{S \times A} \text{ (L/ha)}$$

Where:

V : Spray volume (L/ha)

F : Nozzle flow rate (L/min)

A : Nozzle spacing (m)

S : Tractor speed (km/h)

600 : Conversion unit

EXAMPLE

Nozzle flow rate 2.55 l/min at 25 psi (DEF-015 nozzle)

Nozzle spacing 3.0 m

Working speed 4.0 km/h

$$V = \frac{F \times 600}{S \times A} \text{ (L/ha)} \quad V = \frac{2.55 \times 600}{4.0 \times 3} \text{ (L/ha)} \quad V = \frac{1,530}{12} = 127.5 \text{ L/ha}$$

ATTENTION

The numbers shown in the above example are illustrative. The correct calibration should be done according to instructions of a technician of trust.

OPERATION AND ADJUSTMENTS

CALIBRATING THE SPRAYER THROUGH A PRACTICAL METHOD

BEFORE CALIBRATING THE SPRAYER CHECK THE FOLLOWING:

- Suction filter: dirt;
- Hoses: twisted or bored;
- Pressure regulator components (valve seat, valve and spring): wear or dirt;
- Pump: proper lubrication (oil level and grease) and leakages;
- Nozzles: same model, wear, flow rate, strainers.

ONCE ABOVE POINTS ARE CHECKED, PROCEED WITH THE CALIBRATION AS FOLLOWS

- 1 - Mark off 50 meters on the ground to be sprayed.
- 2 - Fill the sprayer's tank.
- 3 - Choose the operating gear.
- 4 - Engage the PTO.
- 5 - Accelerate until reaching 540 rpm at the PTO.

564

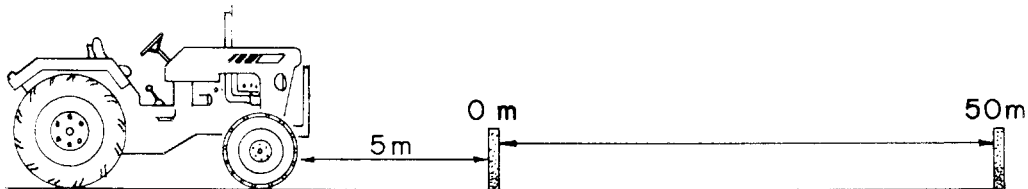

- 6 - Start moving at least 5 meters before the initial mark.
- 7 - Note the time it takes the tractor to travel 50 meters. (Ex.: 45 seconds)
- 8 - On irregular terrain, repeat this operation several times and take the average.
- 9 - Stop the tractor with the acceleration used to travel the 50 meters, open the nozzles and adjust the pressure according to the recommendation for the different types of nozzles:
 - Cone nozzles: from 45 to 200 psi
 - Flat fan nozzles: from 15 to 60 psi
 - Deflector nozzles: from 15 to 30 psi
- 10 - Collect the spraying volume of all nozzles during the same time taken to travel the 50 meters. (Total flow rate of the 5 nozzles: 1.91 L)
- 11 - Measure the spray swath (allowed swath: 2.90 to 3.62 m)

NOTE: Swath considered for this calculation: 3 m)

CALCULATING THE AREA:

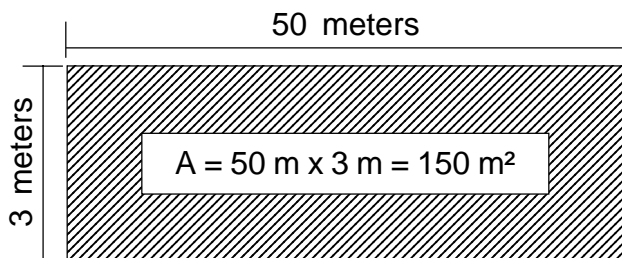

CALCULATING THE SPRAYING VOLUME:

150 m^2
 1.91 L (during 45 seconds)
 $10,000 \text{ m}^2 = (1 \text{ ha})$
 $1.91 \text{ liters divided by } 150 \text{ m}^2 = 0.0127 \text{ L/m}^2$
 $0.0127 \times 10,000 = 127 \text{ L/ha}$

- NOTE: 1^o- If the spraying volume obtained is below that wished, increase the pressure, decrease the speed (but 540 rpm at PTO) or change the nozzles for others of higher flow rate.
- 2^o- If the spraying volume is above that wished, decrease the pressure, increase the speed (but keep 540 rpm at PTO) or change the nozzles for others of lower flow rate.

OPERATION AND ADJUSTMENTS

DILUTING THE CHEMICALS

ATTENTION

NEVER run the sprayer for long time with less than 50 liters of water in the tank to avoid damage to the pump.

Always use the following individual protective clothing when handling chemicals:

- Impermeable wide-brimmed hat
- Goggles
- Mask
- Long-sleeved working clothes
- Impermeable gloves
- Impermeable boots

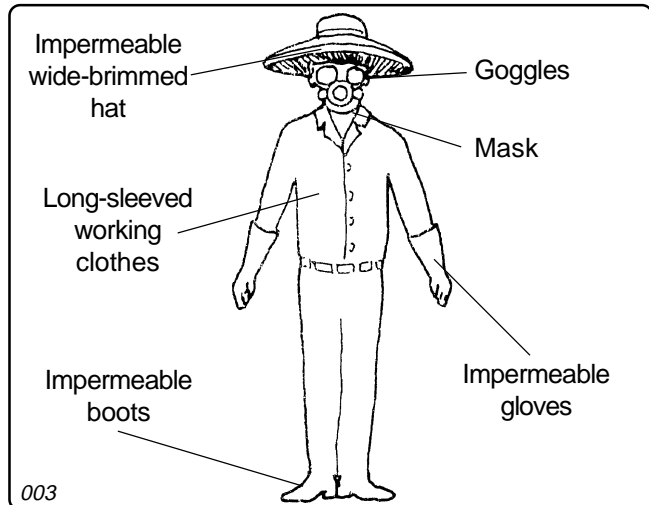

PREPARING THE CHEMICAL MIXTURE

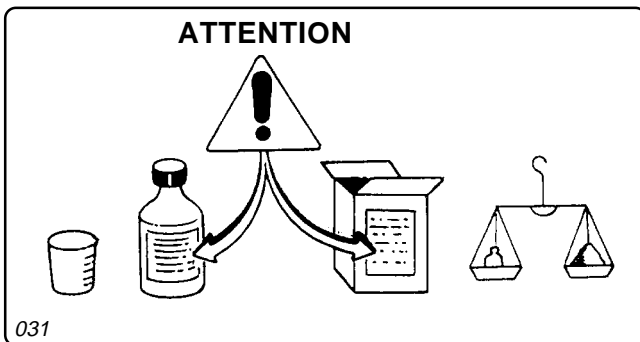

- Read carefully the chemicals manufacturer's label.

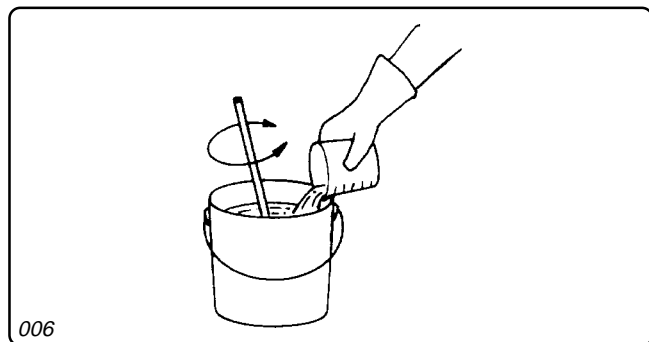

- Pour the chemical product into a bucket with little water and stir.

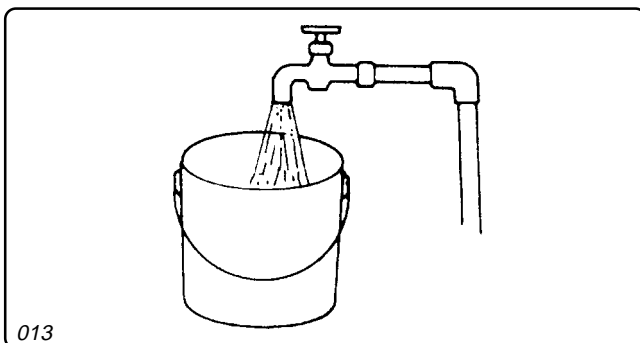

- Add water until filling the bucket up.
- Stir until the mixture is homogeneous.

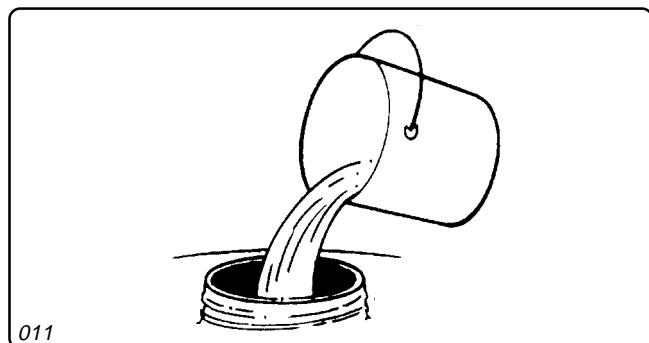

- Pour the solution into the sprayer tank.
- Install the tank lid and make sure there is no leakage.

ATTENTION
ALWAYS FOLLOW TECHNICAL RECOMMENDATIONS WHEN HANDLING CHEMICALS.

MAINTENANCE

GUIDELINES

- Daily, after finishing the spraying, put clean water on the tank, remove the nozzles and run the sprayer till empty.
- Remove, clean and replace the nozzles and the filters.
- Clean the main filter.
- Wash the outside and inside of the sprayer.

These procedures will avoid problems with the sprayer in future application such as : obstruction of the filters, nozzles, extensions and ducts, as well as protect your life.

ATTENTION

NEVER WASH SPRAYERS OR PROTECTIVE CLOTHING (MASK,GLOVES, WORKING CLOTHES, ETC.) IN OR CLOSE TO RIVERS, LAKES, STREAMS, BROOKS, DAMS, ETC.

- Take off and wash all the individual protective equipment.
- Wash the working clothes separately from other clothes.
- Take a shower with plenty of water and soap and put clean clothes.

COMPONENTS

MAIN FILTER

The frequency of filter cleanings depends on the quality of water and type of chemicals used.

Clean the suction filter whenever filling the tank or necessary.

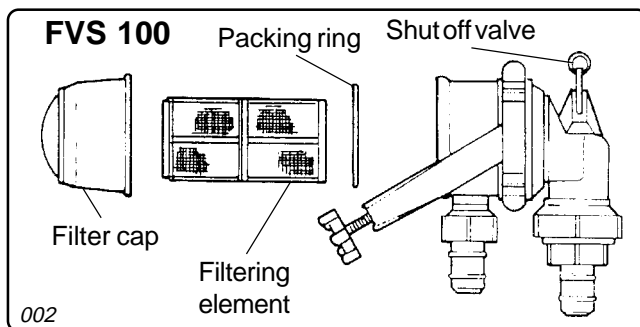

PRESSURE REGULATOR

- Disassemble the pressure regulator every 100 working hours.
- Check for wear on the valve and valve seat.
- Replace the parts if necessary.

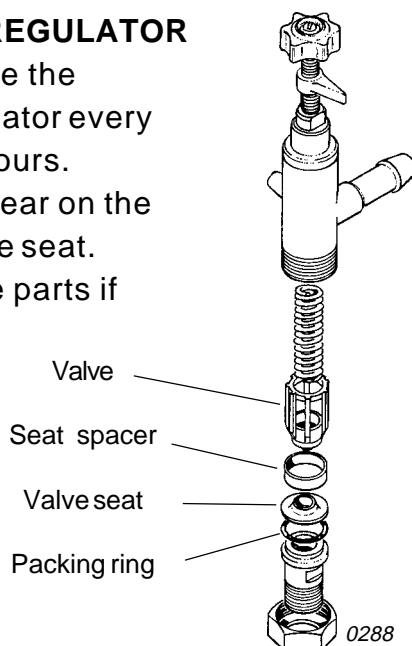

IN-LINE FILTER

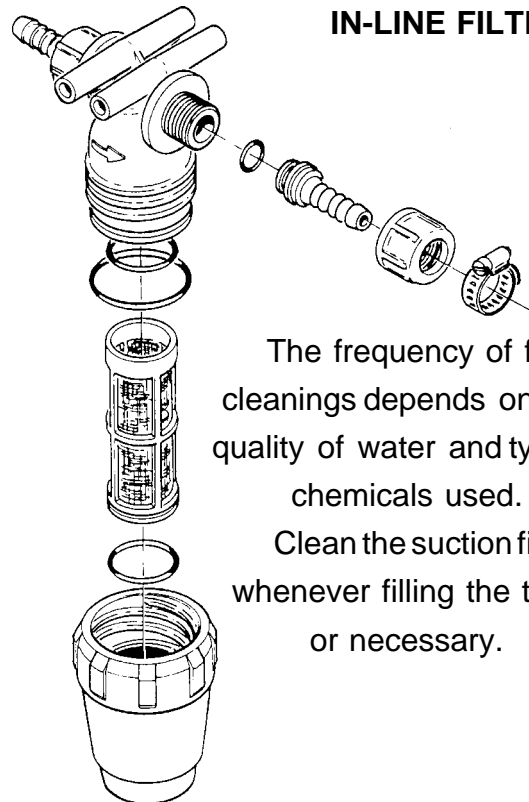

The frequency of filter cleanings depends on the quality of water and type of chemicals used.

Clean the suction filter whenever filling the tank or necessary.

SPRAY NOZZLES

- Clean the nozzles and strainers daily or whenever necessary.

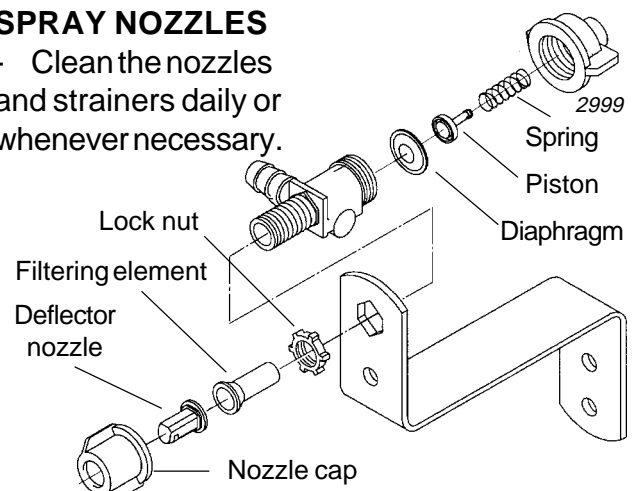

MAINTENANCE

LUBRICATION TABLE

PRODUCT	LOCATION	FREQUENCY	SPECIFICATIONS	RECOMMENDED PRODUCTS
GREASE	PUMP: JP-401 - JP-402 PTO SHAFT GREASE NIPPLES	DAILY	LITHIUMBASE GREASE NGLI - 2	MULTIFAK EP-2 MOBILGREASE 77 LUBRAX GMA-2 BEACON EP-2 AND SIMILAR PRODUCTS
	WINGS JOINT	50 HOURS		

NOTE: The order of the recommended products does not imply any preference for mark or products.

LUBRICATION POINTS

ATTENTION
STOP THE SPRAYER AND TURN OFF THE TRACTOR'S ENGINE
BEFORE SERVICING ANY PART OF THE SPRAYER.

PUMP

Lubricate the pump daily using one of the grease marks indicated in the lubrication table.

NOTE: In case of more detailed maintenance, such as replacement of piston cups, bearings, etc.), please consult your Jacto dealer.

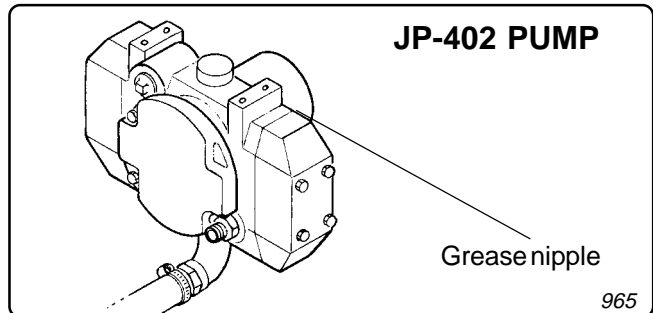

PTO SHAFT

Lubricate daily.
FOR MORE INFORMATION ON THE PTO SHAFT, PLEASE CONSULT THE SECTION MAINTENANCE - PTO SHAFT.

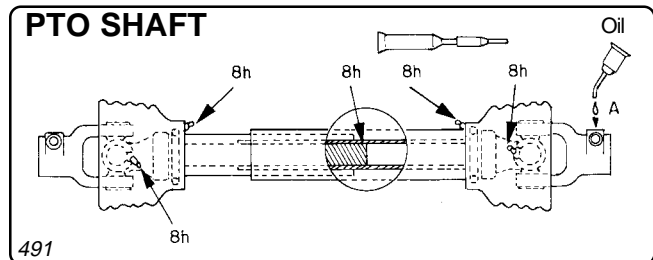

PROTECTIVE WINGS JOINT

Lubricate every 50 hours.

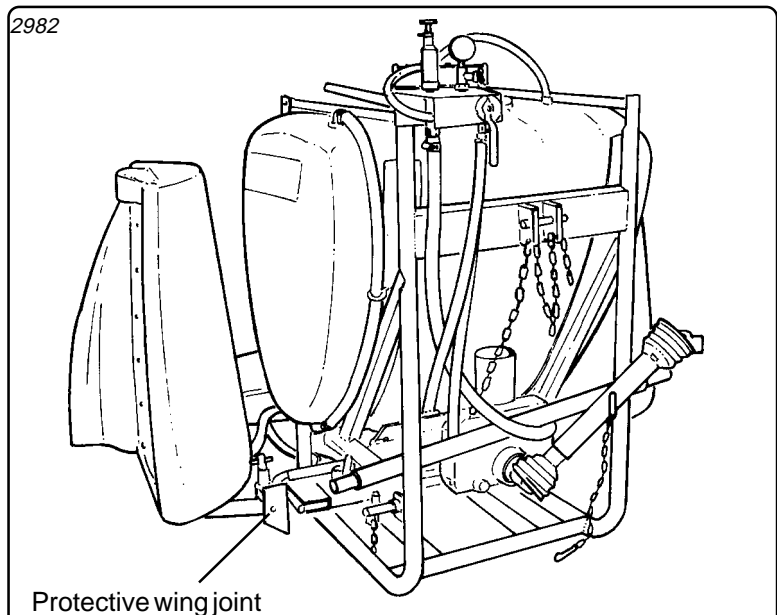

MAINTENANCE

PTO SHAFT (Conventional)

USE, MAINTENANCE, DISASSEMBLING AND ASSEMBLING OF PTO SHAFT WITH PROTECTION GUARDS
ATTENTION: ALWAYS STOP THE SPRAYER AND TURN OFF THE TRACTOR ENGINE BEFORE SERVICING IT

01- CONNECTING

- Check the PTO shaft length.
- Adjust the length by cutting the tubes and protection guards proportionately.

Note: File and remove all burrs.

- Lubricate the male and female tubes.
- Connect the PTO shaft and install the safety chain.

Note: Leave some slack on the chain considering angular movements.

- Disengage the PTO when making sharp turns.

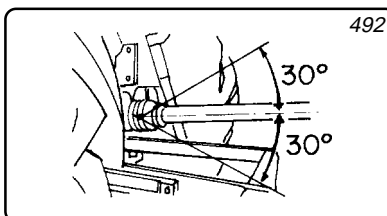
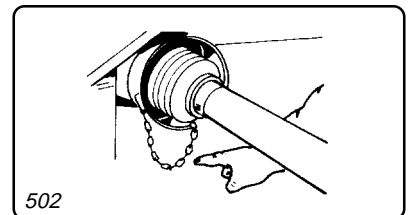
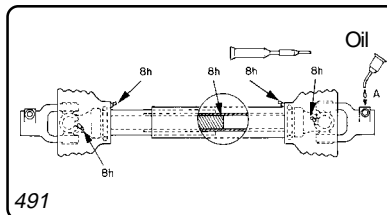
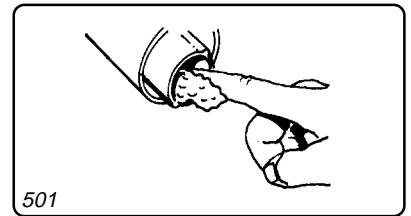
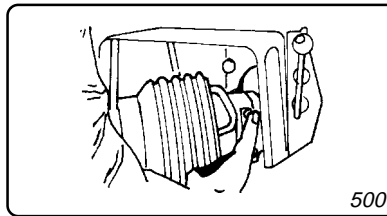

ONLY OPERATE WITH PTO SHAFT EQUIPPED WITH PROTECTION GUARDS.

02-SERVICING

a) DISASSEMBLING

- 1- Remove the lock screw.
- 2- Turn the guard cone until the indicated position.
- 3- Pull the guard cone.
- 4- Remove the sliding ring.

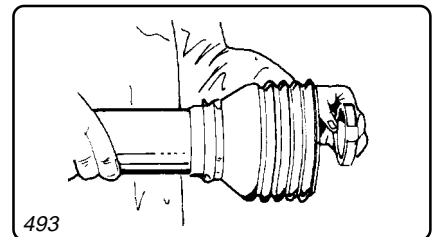
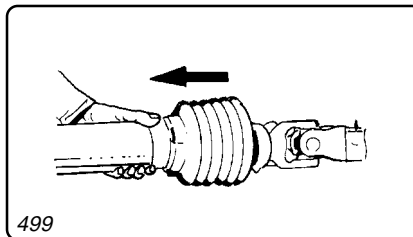
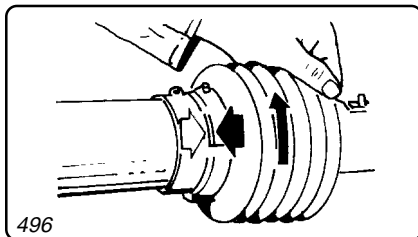
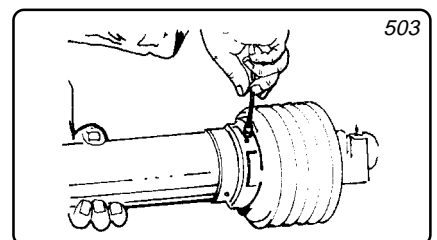

b) ASSEMBLING

- 5- Clean and lubricate the male and female tubes.
- 6- Install the sliding ring into the fitting with the grooves pointing toward the tube.

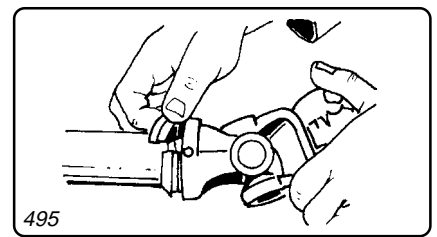
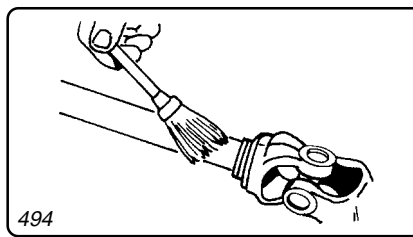

- 7- Install the protection guards.

- 8- Turn the guard cone until the indicated position.

- 9- Install the lock screw.

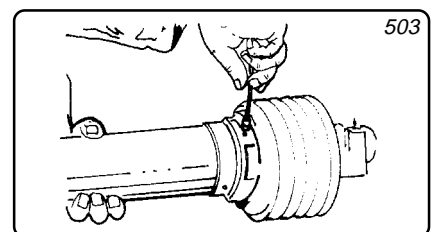
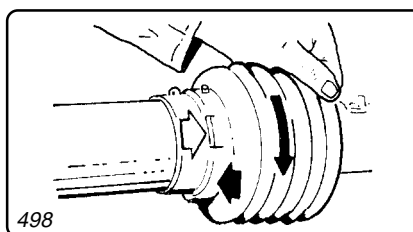
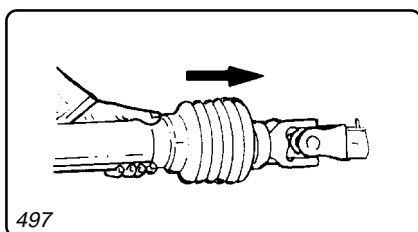

MAINTENANCE

DECALS

Jacto sprayers have several decals aiming to direct on the use and maintenance as well as to warn about dangerous and damageous locations and procedures.

Keep them in place because they are important help to the operator and people working and standing around the sprayer.

<i>DESCRIPTION</i>	<i>PART NO.</i>	<i>QUANTITY</i>
<i>INSTRUCTIONS ON THE PTO SHAFT</i> <i>(PORTUGUESE / ENGLISH/ SPANISH)</i>	<i>428631</i>	<i>01</i>
<i>"ATENÇÃO: PRODUTOS QUÍMICOS PODEM..."</i> <i>(PORTUGUESE)</i>	<i>039420</i>	<i>01</i>
<i>"PERIGO: NÃO FIQUE PRÓXIMO AO CARDÃ..."</i> <i>(PORT./ENG./SP.)</i>	<i>039396</i>	<i>01</i>
<i>LUBRIFICAR DIARIAMENTE ["LUBRICATE DAILY"]</i>	<i>625202</i>	<i>01</i>
<i>LIMPAR O FILTRO A CADA ABASTECIMENTO</i> <i>["LUBRICATE FILTER WHENEVER FILLING"]</i>	<i>515734</i>	<i>01</i>
<i>OK - TESTE FINAL ["OK - FINAL TEST"]</i>	<i>013169</i>	<i>01</i>
<i>LOGOTIPO PH-400 SA</i>	<i>868034</i>	<i>02</i>

ATTENTION

**REPLACE THE DECALS IN CASE OF DAMAGE OR ILLEGIBILITY.
YOU MAY ORDER THEM THROUGH THE NUMBERS SPECIFIED ABOVE.**

MAINTENANCE

WINTER STORAGE

ATTENTION: In areas where temperatures drop to 0° or less, the water accumulated in the pump can freeze and cause serious damages. To avoid such damages, refer to the figure below and proceed as instructed.

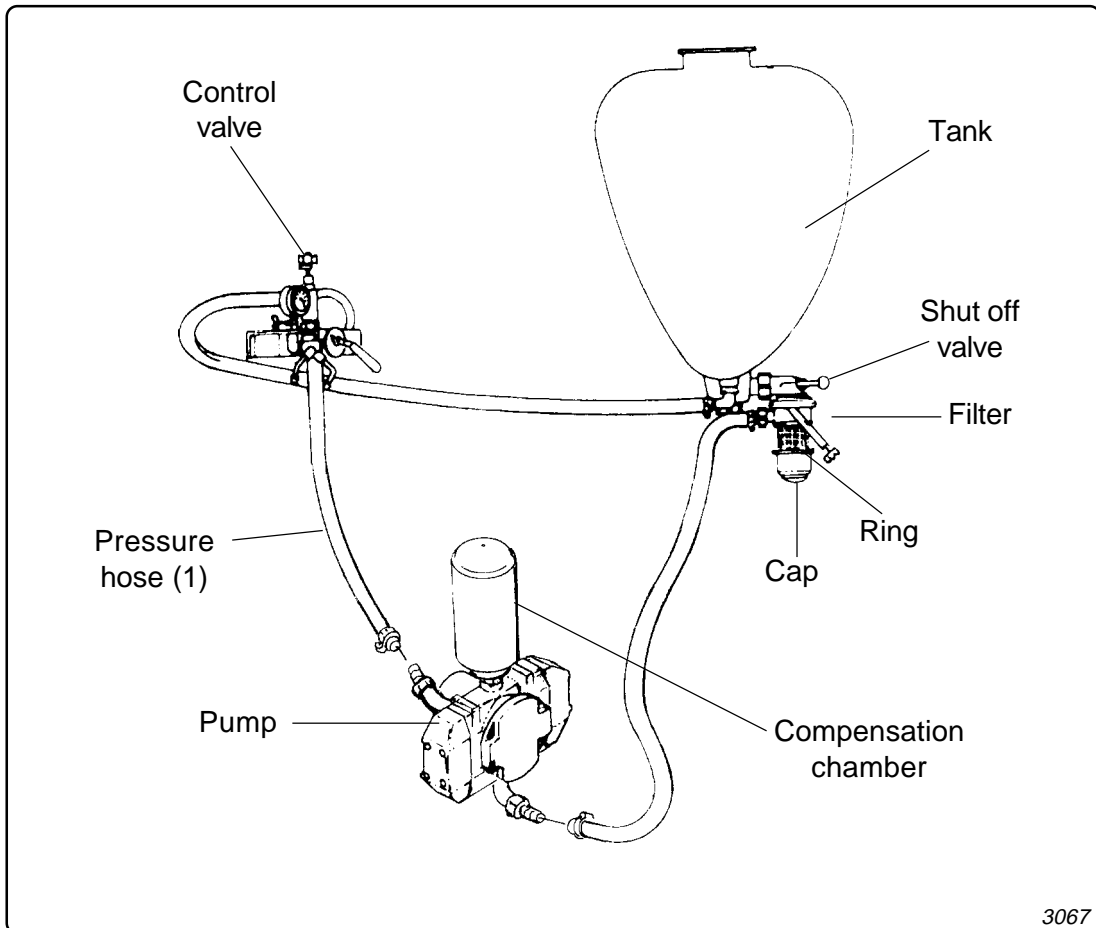

PROCEDURES

- Empty the tank completely by removing the lid and opening the filter shut off valve.
- Disconnect the pressure hose (1) from the pump.
- Run the sprayer for about 30 seconds at half speed.

NOTE: To avoid damage to the pump, do not run the tractor over the recommended time.

- Afterward, connect the hoses again to the pump.
- Repeat this operation at the end of each spraying day during winter time to avoid problems in future spray applications.

MAINTENANCE

TROUBLE-SHOOTING

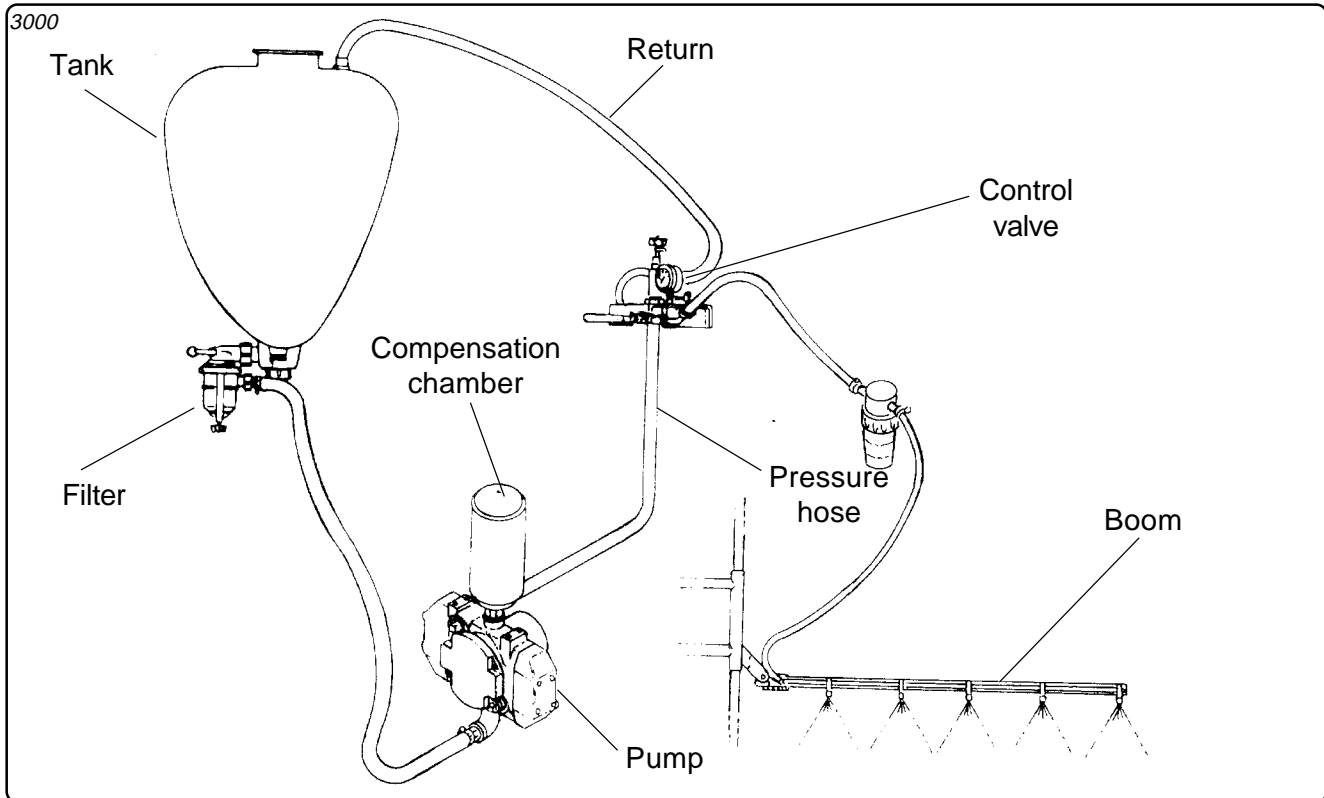

PROBLEMS - CAUSES - SOLUTIONS

Whenever Jacto sprayers equipped with piston pumps show problems, try to classify them in one of the following four groups.

a) LACK OF SUCTION AND PUMPING CAPACITY

No liquid flow through the nozzles.
 No return to the tank.
 Pressure gauge does not indicate pressure.

b) PRESSURE DEFICIENCY

(PARTIAL LACK OF PRESSURE)
 Desired pressure is not attained.
 Specified nozzle spraying angle is not attained.
 Pressure gauge shows lower pressure.

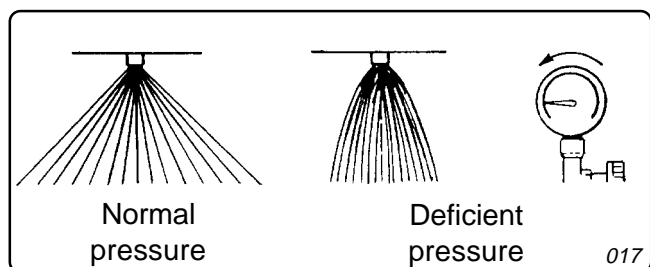

c) PRESSURE OSCILLATION

The pressure gauge needle oscillates.
 The nozzle spraying angle oscillates.

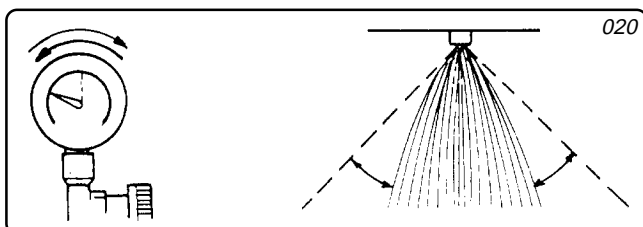

d) INTERMITTENT PRESSURE

The pressure gauge needle vibrates with intensity.
 The pressure hoses vibrate with intensity.
 The nozzles spraying angle varies.

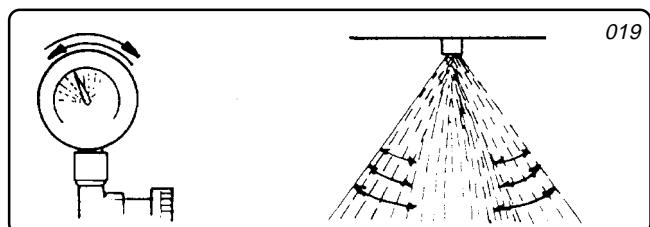

MAINTENANCE

a - LACK OF SUCTION AND PUMPING CAPACITY

PROBABLE CAUSES	SOLUTIONS
1- PTO not turning.	The sprayer should be run with 540 rpm at PTO. Check visually whether the pump is being run.
2- Lack of water in the tank.	To run the hydraulic system, it is necessary to contain a minimum quantity of liquid, otherwise there will be no pressure.
3- Filter shut off valve closed.	When the pump runs, liquid will pass through the valve even in the closed position, however it will be insufficient. Open it.
4- Dirty filter.	Impurities in the filter prevent a free liquid flow. Clean the filter whenever filling the tank, or with more frequency depending on the quality of the water and the type of product applied.
5- Obstruction in the intake hoses.	Check whether the hose connecting the filter to the pump is twisted. Check whether there is any obstruction in the hoses from tank to filter. Fill up the tank with water, open the valve and verify if it flows freely.
6- Air in the system.	Check the filter packing ring. The filter should not leak.
7- Insufficient pump suction.	Remove the cover of the suction valves. Check the condition of the valves and replace them if necessary.

b - PRESSURE DEFICIENCY

PROBABLE CAUSES	SOLUTIONS						
1- Low PTO rpm.	The proper PTO rotation is 540 rpm.						
2- Filter shut off valve closed.	When the pumps runs, liquid will pass through the valve even in the closed position, however flow will be insufficient.						
3- Filter partially obstructed.	The filter should be clean to allow free liquid flow.						
4- Intake hose partially obstructed.	A deficient pump will cause depressurization. Check whether the hose connecting the filter to the pump is twisted. Verify whether there is any obstruction in the hoses connecting the tank to the filter. Fill the tank with water, open the valve and observe if it flows freely.						
5- Air in the system.	Check the connections and the o'rings of the tank outlet and the pump inlet.						
6- Pressure regulator.	Check the valve and valve seat.						
7- Worn nozzles.	Check whether the nozzle flow rate is within the recommended. Replace the nozzles when the flow rate exceeds 10% of the specified. Use only nozzles recommended by the sprayer manufacturer.						
8- Pump with lower flow rate.	Disconnect the pressure hose from the control valve. Run the sprayer at 540 rpm. Collect water for one minute and measure. The volume collected should approximate this shown below for each pump model: <table style="width: 100%; border: none;"> <tr> <td style="width: 50%;">JP - 402 = 38 L/min</td> <td style="width: 50%;">JP - 100 = 100 L/min</td> </tr> <tr> <td>JP - 42 = 42 L/min</td> <td>JP - 150 = 150 L/min</td> </tr> <tr> <td>JP - 75 = 75 L/min</td> <td>JP - 300 = 300 L/min</td> </tr> </table>	JP - 402 = 38 L/min	JP - 100 = 100 L/min	JP - 42 = 42 L/min	JP - 150 = 150 L/min	JP - 75 = 75 L/min	JP - 300 = 300 L/min
JP - 402 = 38 L/min	JP - 100 = 100 L/min						
JP - 42 = 42 L/min	JP - 150 = 150 L/min						
JP - 75 = 75 L/min	JP - 300 = 300 L/min						

MAINTENANCE

TROUBLE-SHOOTING

c - PRESSURE OSCILLATION

PROBABLE CAUSES	SOLUTIONS
1- Loose belts.	Check belt tension and tighten if necessary.
2- Air in the intake system.	Check for damaged hoses, filter packing rings, etc., and repair if necessary.
3- Pressure regulator.	Check the regulator components and clean or replace them if necessary.

d - INTERMITTENT PRESSURE

PROBABLE CAUSES	SOLUTIONS
1- Filter shut off valve closed.	When the pumps runs, liquid will pass through the valve even in the closed position, however flow will be insufficient.
2- Pump valve deficiency.	Valve with sealing deficiency or stuck due to impurities.

GENERAL CARE

HANDLING AGRICULTURAL SPRAYER AND CHEMICALS

We warn the owners and users that the UNREASONABLE USE of this sprayer and chemicals applied may cause damage to people, properties, animals and environment.

Read carefully and understand thoroughly this manual and the recommendations of the chemicals manufacturers.

Follow strictly the instructions for proper use of this sprayer and chemicals to ensure more safety and efficiency when spraying your crops.

AFTER SPRAYING

ATTENTION: Avoid leaving chemical mixture residues in the tank. For the last pass, prepare the chemical solution in enough quantity to spray the remaining of the crop.

- Empty completely the tank and wash thoroughly the sprayer in a proper decontamination place.
- Wash the inside and outside of the sprayer with clean water and detergent.
- Disassemble and clean each nozzle assembly with fine brush, water jet or compressed air.
- Dry, lubricate and store the sprayer in a dry and covered place.
- Repaint the damaged metallic parts to prevent corrosion.
- Spray the mettalic parts with a mixture of lubricating oil at 80% and gas oil at 20% to prevent corrosion.
- Take off the individual protective clothing and wash it separately from other clothes.

DANGER

SAFETY OBSERVATION

**OPERATING THIS SPRAYER WITHOUT FOLLOWING THE INSTRUCTIONS
MAY RESULT IN SERIOUS INJURY OR DEATH.**

STATEMENT OF LIMITED WARRANTY

MÁQUINAS AGRÍCOLAS JACTO S.A. warrants the equipment described herein and agrees to repair or replace parts and components which, under normal operation and wear, following the technical recommendations, show DEFECTS IN MATERIAL OR WORKMANSHIP.

WARRANTY PERIOD:

- One (1) year from the purchase date by the original retail purchaser.

WARRANTY APPLICATION:

Jacto or its authorized representative shall honor this warranty, if any part or component shows confirmed defect in workmanship.

IT SHALL BE UNDERSTOOD THAT THE REPLACEMENT OF ASSEMBLIES SUCH AS PUMPS, CONTROL VALVES, ENGINES, TRANSMISSIONS, HYDRAULIC PISTONS AND SIMILAR ONES SHALL ONLY BE PERFORMED IN CASE THAT THE DEFECT CANNOT BE REPAIRED BY REPLACING PARTS AND/OR COMPONENTS, NEW OR RECONDITIONED, ACCORDING TO RULES OR AUTHORIZED REPRESENTATIVE.

THIS WARRANTY IS NULL AND VOID IF:

- Equipment is not used in accordance with the INSTRUCTION MANUAL, overwork or accidents.
- Improper preventive maintenance or performed by unauthorized people.
- Modification of the equipment in any way from the original design.
- Change, damage, or loss of the product identification plate.
- Utilization of parts and components not supplied by JACTO.

PRODUCT REGISTRATION CARD MUST BE COMPLETED BY THE ORIGINAL RETAIL PURCHASER, AND RETURNED TO JACTO DEALER WITHIN 30 DAYS OF PURCHASE DATE.

WARRANTY EXCLUSIONS:

- Parts considered as normal maintenance such as: filtering elements, belts, hoses, nozzles, pistons, pressure gauges, as well as usual maintenance, adjustments, retightening, lubrication and painting.
- Parts which show wear or tear due to use, UNLESS THEY SHOW DEFECTS IN WORKMANSHIP, ASSEMBLY OR MATERIAL.
- Hydraulic, lubricating oils and grease.
- Injuries of personal or material nature to the user, owner, or third parties.
- Additional charges resulting from paralyzation and repair of the equipment.
- Freight charges, pick up and delivery charges.
- Damages of any nature resulting from action of gases or liquids used in the equipment.

GENERAL INFORMATION:

- Defective parts replaced under warranty period shall be property of JACTO.
- Eventual delays in performing services do not confer the owner the right to indemnity or to extension of the warranty period.
- JACTO reserves the right to change its products or to interrupt manufacturing the equipment.
- THIS LIMITED WARRANTY shall be understood by its expressed terms, and no one in anyway subject to JACTO shall be authorized to modify or amplify the conditions prescribed herein.
- In case of warranty claim, contact the authorized dealer supplying all information required for prompt service. Do not forget the identification of the equipment, total hours of work, and the noticed defect.

FOR THIS WARRANTY TO BECOME EFFECTIVE THE PRODUCT REGISTRATION CARD FOUND IN THE INSTRUCTION MANUAL MUST BE FILLED IN AND RETURNED TO YOUR JACTO DEALER. THIS CARD MUST BE SIGNED BY THE ORIGINAL RETAIL PURCHASER, INDICATING THAT HE HAS READ AND UNDERSTOOD ALL SAFETY AND OPERATIONAL INSTRUCTIONS IN THE MANUAL, FURTHER THE RETAILING DEALER HAS EXPLAINED TO THE ORIGINAL RETAIL PURCHASER ALL SAFETY INSTRUCTIONS. IN NO CASE WILL WARRANTY BE SUPPLIED UNTIL THIS CARD, PROPERLY COMPLETED AND SIGNED, IS ON FILE WITH JACTO RETAILING DEALER.



PRODUCT REGISTRATION CARD

INVOICE NUMBER: _____ DATE: ____ / ____ / ____

RETAILING DEALER: _____

PHONE: _____ CITY: _____ STATE: _____

MACHINE: _____ MODEL: _____

SERIES: _____ MACHINE No.: _____ PUMP No.: _____

ORIGINAL RETAIL PURCHASER: _____

ADDRESS: _____ PHONE: _____

CITY: _____ STATE: _____

PURCHASE DATE BY THE ORIGINAL RETAIL PURCHASER: ____ / ____ / ____

THE WARRANTY IS IN FORCE AS OF THIS DATE: ____ / ____ / ____

RETAIL PURCHASER SIGNATURE: _____

Original retail purchaser's copy



PRODUCT REGISTRATION CARD

INVOICE NUMBER: _____ DATE: ____ / ____ / ____

RETAILING DEALER: _____

PHONE: _____ CITY: _____ STATE: _____

MACHINE: _____ MODEL: _____

SERIES: _____ MACHINE No.: _____ PUMP No.: _____

ORIGINAL RETAIL PURCHASER: _____

ADDRESS: _____ PHONE: _____

CITY: _____ STATE: _____

PURCHASE DATE BY THE ORIGINAL RETAIL PURCHASER: ____ / ____ / ____

THE WARRANTY IS IN FORCE AS OF THIS DATE: ____ / ____ / ____

RETAIL PURCHASER SIGNATURE: _____

**URGENT
RESPOND WITHIN 30 DAYS
FIRST CLASS POSTAGE REQUIRED**